



# BYTOM

## **IMPULSE INTEGRATOR**

*Model of 1981*

- *Three independent trigger/gate 4:1 combiner sections (OR gate)*
- *Upper and lower combiner sections can be normalled to the middle one*
- *Basic computing of max value of input signals*



**XAOC DEVICES SP. Z O. O.**  
WORKING CLASS ELECTRONICS  
MADE IN THE EUROPEAN UNION  
[WWW.XAOCDEVICES.COM](http://WWW.XAOCDEVICES.COM)

## MODULE OVERVIEW

Salut! Thank you for purchasing this Xaoc Devices product. Bytom [ˈbitɒm] is a utility module that combines multiple gate or trigger signals. It consists of three 4-input sections whose outputs may be independent or can be combined using switches and cascaded OR logic. Bytom facilitates creating rhythms, complex modulations, and patch automation.

Please note that the OR function requires non-linear processing; thus, Bytom is NOT a mixer as it does not add signals. While it can accept analog waveforms, its main purpose is to process two-state (on/off) signals, such as gates or triggers.

To better understand the device and avoid common pitfalls, we strongly advise the user to read the entire manual before using the module.

fig. 1: BYTOM FRONT PANEL LAYOUT AND CONTROLS

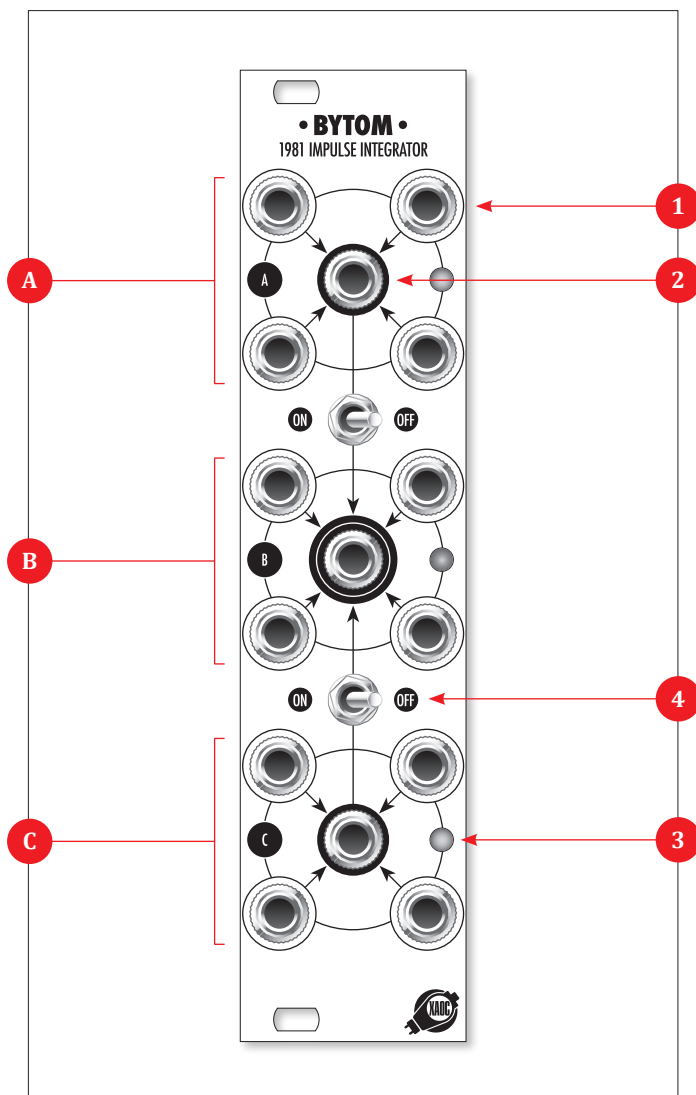

## INSTALLATION

The module requires 6hp worth of free space in the Eurorack cabinet. Always turn the power off before plugging the module into the bus board using the supplied ribbon cable! The power cable must be plugged into the bus board, paying close attention to polarity orientation. The red stripe indicates the negative (-12V) rail and should match the corresponding marks on both the bus board and the unit. The module itself is secured against reversed power connection; however, reversing the 16-pin plug may cause serious damage to other components of your system because it will short-circuit the +12V and +5V power rails.

The module should be fastened by mounting the supplied screws before powering up.

## MODULE OVERVIEW

The front panel of Bytom (fig. 1) consists of three sections: A, B, and C. Each can process up to four signals fed to four input sockets ①. Each section features an output ②, marked by a black ring around the jack. You can patch up to four separate signal sources using any combination of inputs in each section. Any unused inputs are ignored. Whenever there is an active gate in any source signal, the output becomes active, and the corresponding LED indicator ③ lights up.

The middle section can optionally combine the signals from the upper and lower sections while the corresponding switches ④ establish the connections according to the arrows drawn on the panel. Thus, depending on the positions of the switches, the output of the middle section is a logic OR of four inputs (section B only), logic OR of eight inputs (section B and A, or B and C), or a logic OR of twelve inputs (sections A, B, and C).

**NOTE:** the individual outputs of the upper and lower sections remain active even when combined with the middle section.

## PRINCIPLE OF OPERATION

The logic diagram of Bytom is shown in fig. 2. Each of the three sections is a logic OR gate operating according to the truth table, fig. 3. A multi-input OR gate generates an active signal (gate ON) every time there is an active signal on ANY of its inputs.

## PATCH IDEAS

*note: negative input voltages are treated as zero or inactive.*

*For example, patching a -8V, -3V, 0V, and 0V into the four inputs of any section results in the output value of 0V. On the other hand, patching -8V, 0V, 3V, and 5V results in 5V at the output.*

### TIMING AND RACE CONDITIONS

*The hardware design of Bytom ensures it can operate at extremely high frequencies (well beyond audio) with no detectable latency. Note that in certain situations, this may yield unexpected results.*

*For example, in a modular environment, events can cascade, allowing upstream events to trigger downstream events. Such causal dependence can yield an unexpected (often unnoticeable) short gap. But you cannot beat physics; combining such non-overlapping impulses may cause discontinuity or multiple edges in Bytom's output.*

*The widths of these artifacts are often below 1 microsecond and, depending on their design, may or may not be registered by subsequent devices in the patch.*

### PATCH IDEAS

*Some sequencers (e.g., Xaoc Devices Moskwa with Ostankino expander) offer individual step outputs that produce triggers or gates each time a particular step is reached within the sequence. Use Bytom to combine such signals into one trigger or gate signal to fire events (e.g., drum sounds) on selected steps of the sequence. For example, combine gates of steps 1 and 5 of an 8-step sequence to fire a BD sound, steps 3 and 7 to fire CP or SD, and steps 2, 4, 6, and 8 for a HH.*

*Similarly, Bytom can combine outputs from a frequency divider/counter (like Xaoc Devices Erfurt), a multi-channel trigger sequencer, or another source of complex trigger patterns (e.g., Xaoc Devices Jena). Bytom's outputs are activated by every trigger or gate signal on any of its inputs, which creates interesting rhythms.*

*Within a complex patch, several independent events may occur (e.g., the EOR of an envelope, a comparator detecting some signal crossing a threshold, a Bernoulli gate output, etc.). An inter-*

*esting arrangement idea is to make a step sequencer advance one step by any occurrence of these events. Bytom is handy in combining all the events into one irregular "clock" signal for the sequencer.*

*The switches feeding the outputs of sections A and C into the middle section B are great performance tools. Suppose you have A percussion element programmed and being played by the signal from Bytom's middle output. In that case, enabling these additional connections in Bytom (A→B, C→B) adds hits within the rhythm, according to what is patched into the top and bottom OR gates.*

*Even when you don't need the OR functions of Bytom in a particular patch, you can use its LED indicators to monitor the states of signals that may not have their own lights in other modules.*

### ACCESSORY

*Our Coal Mine black panels are available for all of the Xaoc Devices modules. Sold separately. Ask your favorite retailer. •*

fig. 2: LOGIC DIAGRAM OF BYTOM

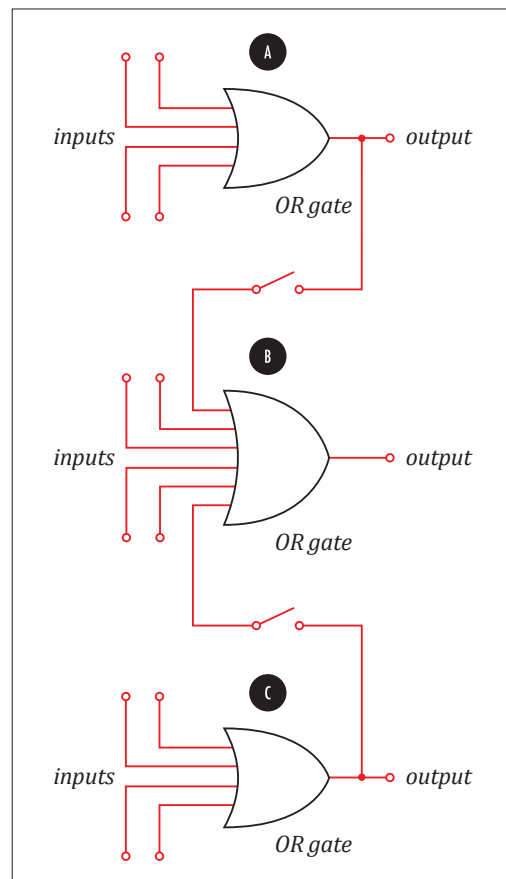

| INPUT X <sub>1</sub> | INPUT X <sub>2</sub> | INPUT X <sub>3</sub> | INPUT X <sub>4</sub> | ... | INPUT X <sub>N</sub> | OUTPUT |
|----------------------|----------------------|----------------------|----------------------|-----|----------------------|--------|
| 0                    | 0                    | 0                    | 0                    | ... | 0                    | 0      |
| 1                    | —                    | —                    | —                    | ... | —                    | 1      |
| —                    | 1                    | —                    | —                    | ... | —                    | 1      |
| —                    | —                    | 1                    | —                    | ... | —                    | 1      |
| —                    | —                    | —                    | 1                    | ... | —                    | 1      |
| —                    | —                    | —                    | —                    | ... | 1                    | 1      |

fig. 3: THRUTH TABLE OF 'OR' LOGIC (MULTIPLE INPUTS). NOTE: A '—' DENOTES ANY (IRRELEVANT) VALUE

**TECHNICAL SPECIFICATION**

| WIDTH | DEPTH TOTAL                    | CURRENT DRAW  | REV. POWER PROTECT. |
|-------|--------------------------------|---------------|---------------------|
| 6hp   | 31mm (including cable bracket) | +10mA<br>-0mA | protected           |

| INPUTS       | OUTPUTS    |
|--------------|------------|
| -10V to +10V | 0V to +10V |

**ALL RIGHTS RESERVED.** CONTENT COPYRIGHT ©2024 XAOC DEVICES. COPYING, DISTRIBUTION, OR COMMERCIAL USE IN ANY WAY IS STRICTLY PROHIBITED AND REQUIRES WRITTEN PERMISSION FROM XAOC DEVICES. SPECIFICATIONS ARE SUBJECT TO CHANGE WITHOUT PRIOR NOTICE. EDITING BY BRYAN NOLL. **WARRANTY TERMS:** XAOC DEVICES WARRANTS THIS PRODUCT TO BE FREE OF DEFECTS IN MATERIALS OR WORKMANSHIP AND TO CONFORM WITH THE SPECIFICATIONS AT THE TIME OF SHIPMENT FOR ONE YEAR FROM THE DATE OF PURCHASE. DURING THAT PERIOD, ANY MALFUNCTIONING OR DAMAGED UNITS WILL BE REPAIRED, SERVICED, AND CALIBRATED ON A RETURN-TO-FACTORY BASIS. THIS WARRANTY DOES NOT COVER ANY PROBLEMS RESULTING FROM DAMAGES DURING SHIPPING, INCORRECT INSTALLATION OR POWER SUPPLY, IMPROPER WORKING ENVIRONMENT, ABUSIVE TREATMENT, OR ANY OTHER OBVIOUS USER-INFLECTED FAULT. **LEGACY SUPPORT:** IF SOMETHING GOES WRONG WITH A XAOC PRODUCT AFTER THE WARRANTY PERIOD IS OVER, THERE IS NO NEED TO WORRY, AS WE ARE STILL HAPPY TO HELP! THIS APPLIES TO ANY DEVICE, WHEREVER AND WHENEVER ORIGINALLY ACQUIRED. HOWEVER, IN SPECIFIC CASES, WE RESERVE THE RIGHT TO CHARGE FOR LABOR, PARTS, AND TRANSIT EXPENSES WHERE APPLICABLE. **RETURN POLICY:** THE DEVICE INTENDED FOR REPAIR OR REPLACEMENT UNDER WARRANTY NEEDS TO BE SHIPPED IN THE ORIGINAL PACKAGING ONLY AND MUST INCLUDE A COMPLETED RMA FORM. XAOC DEVICES CAN NOT TAKE ANY RESPONSIBILITY FOR DAMAGES CAUSED DURING TRANSPORT. SO BEFORE SENDING US ANYTHING, PLEASE CONTACT US AT SUPPORT@XAOCDEVICES.COM. NOTE THAT ANY UNSOLICITED PARCEL WILL BE REJECTED AND RETURNED! **GENERAL INQUIRIES:** FOR USER FEEDBACK SUGGESTIONS, DISTRIBUTION TERMS, AND JOB POSITIONS, FEEL FREE TO CONTACT XAOC DEVICES AT INFO@XAOCDEVICES.COM. PLEASE VISIT XAOCDEVICES.COM FOR INFORMATION ABOUT THE CURRENT PRODUCT LINE, USER MANUALS AND FIRMWARE UPDATES.



**XAOC DEVICES SP. Z O. O.**  
 WORKING CLASS ELECTRONICS  
 MADE IN THE EUROPEAN UNION  
 WWW.XAOCDEVICES.COM

