

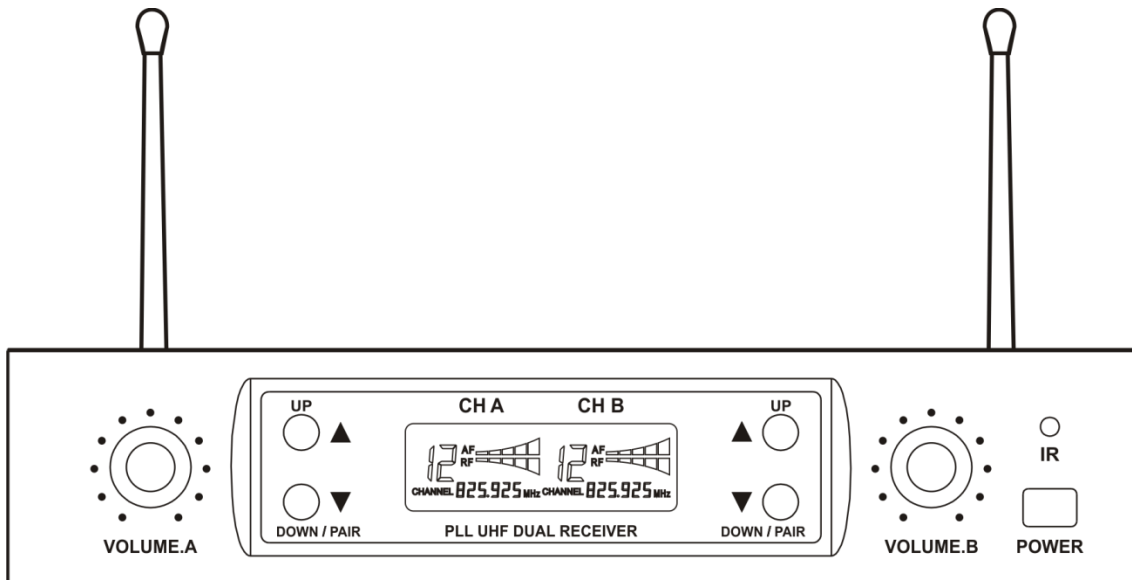

MANUAL



ENGLISH

COM-42

V1

Ordercode: D1464

Table of contents

Warning	2
Safety Instructions	2
Operating Determinations	3
Connection with the mains	3
Return Procedure	4
Claims	4
Description of the device	5
Features	5
Frontside	5
Backside	6
Microphone	7
Installation	8
Set Up and Operation	8
Inserting/replacing the battery	9
Adjusting the squelch threshold	9
Tips for achieving maximum performance	9
Connection Cables	10
Maintenance	11
Troubleshooting	11
Product Specifications	12
Dimensions	13

Warning



**For your own safety, please read this user manual carefully
before your initial start-up!**



Unpacking Instructions

Immediately upon receiving this product, carefully unpack the carton and check the contents to ensure that all parts are present, and have been received in good condition. Notify the dealer immediately and retain packing material for inspection if any parts appear damaged from shipping or the carton itself shows signs of mishandling. Save the carton and all packing materials. In the event that a device must be returned to the factory, it is important that the device is returned in the original factory box and packing.

Your shipment includes:

- DAP Core COM-42
- DC power adapter 15V 300mA
- 2 antennas
- 2 microphones
- User manual

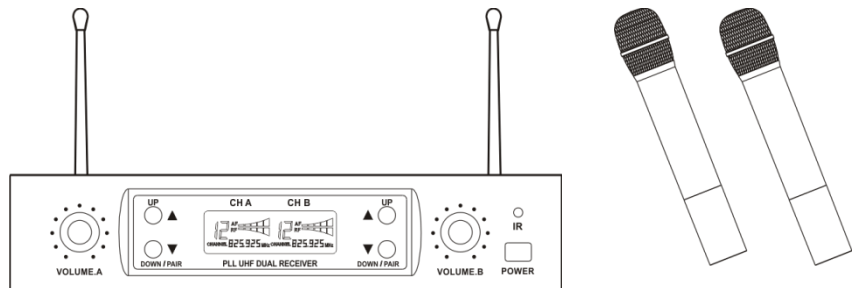

CAUTION!
Keep this device away from rain and moisture!
Unplug mains lead before opening the housing!



Safety Instructions

Every person involved with the installation, operation and maintenance of this system has to:

- be qualified
- follow the instructions of this manual



CAUTION! Be careful with your operations.
**With a dangerous voltage you can suffer
a dangerous electric shock when touching the wires!**



Before the initial start-up, please make sure that there is no damage caused by transportation. Should there be any, consult your dealer and do not use the system.

To maintain perfect condition and to ensure a safe operation, it is absolutely necessary for the user to follow the safety instructions and warning notes written in this manual.

Please consider that damages caused by manual modifications to the system are not subject to warranty.

This system contains no user-serviceable parts. Refer servicing to qualified technicians only.

IMPORTANT:

The manufacturer will not accept liability for any resulting damages caused by the non-observance of this manual or any unauthorized modification to the device.

- Never remove warning or informative labels from the unit.
- Never leave any cables lying around.
- Do not open the device and do not modify the device.
- Do not connect this device to a dimmerpack.
- Do not switch the system on and off in short intervals, as this would reduce the system's life.
- Only use device indoor, avoid contact with water or other liquids.
- Avoid flames and do not put close to flammable liquids or gases.
- Always disconnect power from the mains, when device is not used or before cleaning! Only handle the power-cord by the plug. Never pull out the plug by tugging the power-cord.
- Make sure you do not use the wrong kind of cables or defective cables.
- Make sure to use the supplied AC adaptor only.
- Make sure that the power-cord is never crimped or damaged. Check the system and the power-cord from time to time.
- If system is dropped or struck, disconnect the power supply immediately. Have a qualified engineer inspect for safety before operating.
- If the system has been exposed to drastic temperature fluctuation (e.g. after transportation), do not switch it on immediately. The arising condensation water might damage your system. Leave the system switched off until it has reached room temperature.
- If your Dap Audio device fails to work properly, discontinue use immediately. Pack the unit securely (preferably in the original packing material), and return it to your Dap Audio dealer for service.
- Repairs, servicing and electric connection must be carried out by a qualified technician.
- WARRANTY: Till one year after date of purchase.

Operating Determinations

- This device is not designed for permanent operation. Consistent operation breaks will ensure that the device will serve you for a long time without defects.
- The maximum ambient temperature $t_a = 40^\circ\text{C}$ must never be exceeded.
- The relative humidity must not exceed 50 % with an ambient temperature of 40°C .
- If this device is operated in any other way, than the one described in this manual, the product may suffer damages and the warranty becomes void.
- Any other operation may lead to dangers like short-circuit, burns, electric shock, crash, etc.

You endanger your own safety and the safety of others!

Connection with the mains

Connect the device to the mains with the power-plug.

Always pay attention, that the right color cable is connected to the right place.

International	EU Cable	UK Cable	US Cable	Pin
L	BROWN	RED	YELLOW/COPPER	PHASE
N	BLUE	BLACK	SILVER	NEUTRAL
	YELLOW/GREEN	GREEN	GREEN	PROTECTIVE GROUND

Make sure that the device is always connected properly to the earth!

Improper installation can cause serious damage to people and property!



Return Procedure



Returned merchandise must be sent prepaid and in the original packing, call tags will not be issued. Package must be clearly labeled with a Return Authorization Number (RMA number). Products returned without an RMA number will be refused. Highlite will not accept the returned goods or any responsibility. Call Highlite 0031-455667723 or mail aftersales@highlite.com and request an RMA prior to shipping the fixture. Be prepared to provide the model number, serial number and a brief description of the cause for the return. Be sure to properly pack fixture, any shipping damage resulting from inadequate packaging is the customer's responsibility. Highlite reserves the right to use its own discretion to repair or replace product(s). As a suggestion, proper UPS packing or double-boxing is always a safe method to use.

Note: If you are given an RMA number, please include the following information on a piece of paper inside the box:

- 01) Your name
- 02) Your address
- 03) Your phone number
- 04) A brief description of the symptoms

Claims

The client has the obligation to check the delivered goods immediately upon delivery for any shortcomings and/or visible defects, or perform this check after our announcement that the goods are at their disposal. Damage incurred in shipping is the responsibility of the shipper; therefore the damage must be reported to the carrier upon receipt of merchandise.

It is the customer's responsibility to notify and submit claims with the shipper in the event that a fixture is damaged due to shipping. Transportation damage has to be reported to us within one day after receipt of the delivery.

Any return shipment has to be made post-paid at all times. Return shipments must be accompanied with a letter defining the reason for return shipment. Non-prepaid return shipments will be refused, unless otherwise agreed in writing.

Complaints against us must be made known in writing or by fax within 10 working days after receipt of the invoice. After this period complaints will not be handled anymore.

Complaints will only then be considered if the client has so far complied with all parts of the agreement, regardless of the agreement of which the obligation is resulting.

Description of the device

The COM-42 is a handheld Set UHF Wireless Microphone.

Features

- Plug and play
- Infra-red synchronization
- Metal handheld microphones
- Color coding stickers included
- Power supply: 15VDC, 300mA
- Frequency response: 50-16.000Hz
- Dynamic: >100dBu
- Carrier Frequency Range: 606-630MHz
- Stability: $\pm 0.005\%$
- Frequency Deviation: ± 225 kHz
- Display Indicator: Channel, Frequency, AF & RF
- Controls: Power ON/OFF, Volume, Pair, Up/Down
- S/N Ratio: >100 dB
- Dimensions, COM-42: 210 x 210 x 48 mm (LxWxH)
- Dimensions, microphone: \varnothing 50 mm x L 260 mm
- Weight, COM-42: 1kg
- Weight, microphone: 0,36kg

Frontside

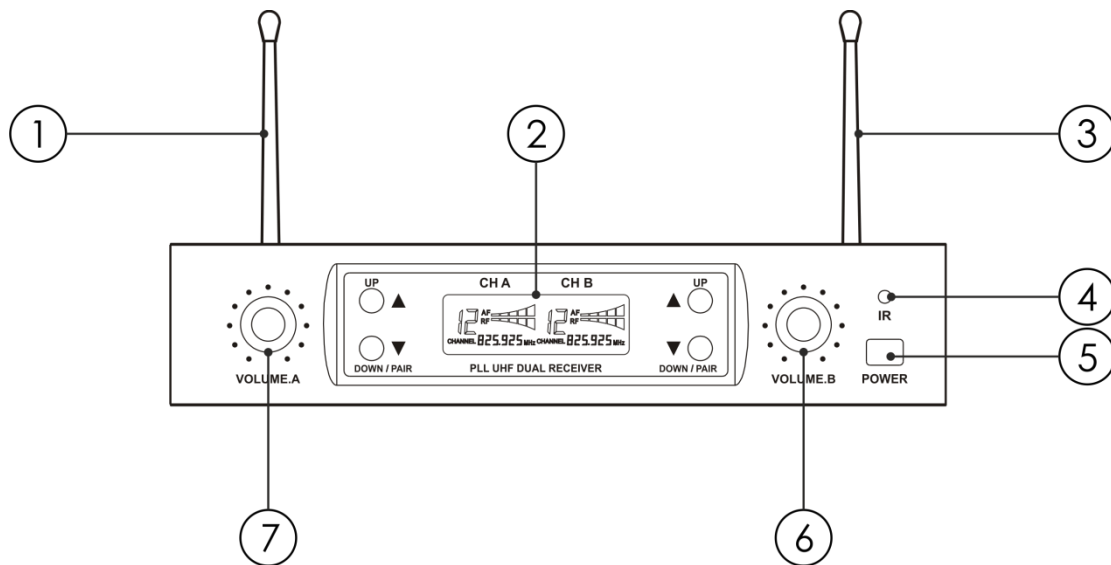

Fig. 01

- ① **Channel A antenna**
- ② **LCD display + control buttons**
- ③ **Channel B antenna**
- ④ **IR LED**
It is responsible for data exchange between the microphone and COM-42.
- ⑤ **Power switch ON/OFF**
Switch the power ON or OFF.
- ⑥ **Channel B volume control**
Turn the control to adjust the output level.
- ⑦ **Channel A volume control**
Turn the control to adjust the output level.

Backside

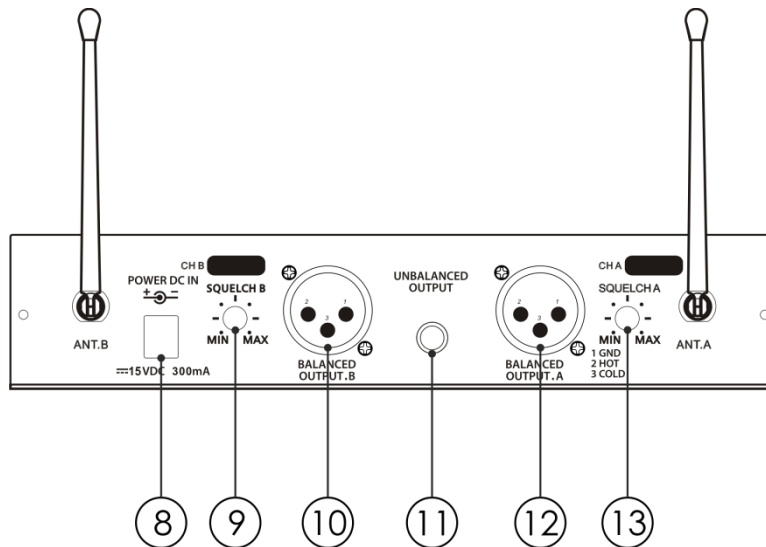

Fig. 02

- ⑧ **DC power adapter 15V 300mA**
Connect the included 15V 300mA DC adapter.
- ⑨ **Channel B squelch control**
Adjust squelch control setting to emphasize either signal quality or system range. This control is factory preset and normally needs no adjustment. For more info see the section on Adjusting the squelch threshold on page 9.
- ⑩ **Channel B balanced XLR audio OUT**
- ⑪ **1/4" Phone jack audio connector OUT**
- ⑫ **Channel A balanced XLR audio OUT**
- ⑬ **Channel A squelch control**
Adjust squelch control setting to emphasize either signal quality or system range. This control is factory preset and normally needs no adjustment. For more info see the section Adjusting the squelch threshold on page 9.

Microphone

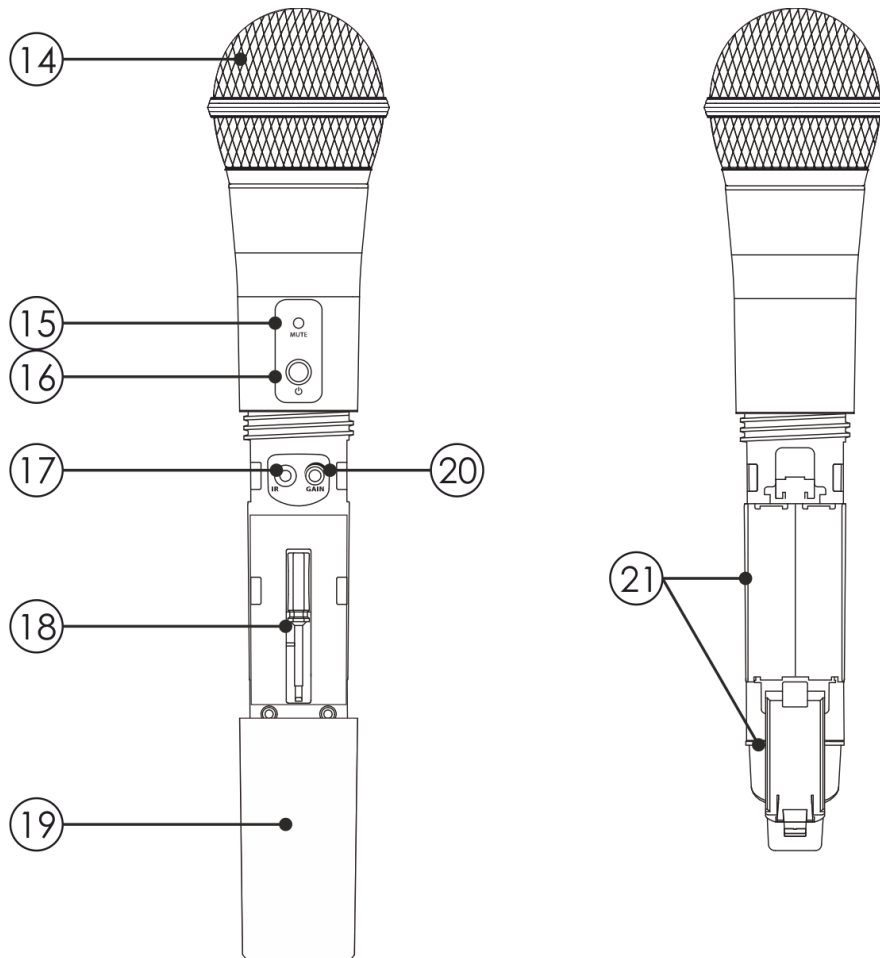

Fig. 03

- ⑭ **Grille**
- ⑮ **LED status indicator**
The LED indicator will light up **green** in **normal operation** mode.
The LED indicator will light up **red** in **mute** mode.
The LED indicator will **flash red** when the **battery is low**.
- ⑯ **Power/mute switch**
Press and hold down the button to switch the microphone ON or OFF. Press once to mute or unmute the microphone.
- ⑰ **IR lens**
The lens captures IR signal from the COM-42 in order to channelize the microphone. The battery cover needs to be open and the IR lens should be facing the COM-42 to load the selected channel.
- ⑱ **Plastic screwdriver**
The screwdriver can be used for adjusting input gain value, by turning the **control (20)**.
- ⑲ **Battery housing cover**
Unscrew the cover to reveal the controls.
- ⑳ **Input gain control**
Turn the control with the included **screwdriver (18)**. Set the input gain to the desired level. The RF level bar on the display of the COM-42 will increase or decrease.
- ㉑ **Battery holder**

Installation

Remove all packing materials from the COM-42. Check that all foam and plastic padding is removed. Connect all cables.

**Always disconnect from electric mains power supply before cleaning or servicing.
Damages caused by non-observance are not subject to warranty.**

Set Up and Operation

Before plugging the unit in, always make sure that the power supply matches the product specification voltage. Do not attempt to operate a 120V specification product on 230V power, or vice versa.

- 01) Refer to Fig. 04. Connect the supplied power DC adapter into the **DC input Connector (08)** at the back of the COM-42. Plug the adapter into a wall socket or other power source.
- 02) Press and hold down the **Power switch (05)** on the front of the COM-42 for 4 seconds. The device is now switched ON.
- 03) Insert the supplied **antennas (01, 03)** in the antenna connectors and rotate fully clockwise. Set the antennas vertically.
- 04) Connect the COM-42's **XLR audio OUT (10, 12)** to the mixer input using an XLR to XLR audio cable or connect the COM-42's **1/4" jack audio connector OUT (11)** to your amplifier's input using a 1/4" phone plug cable.

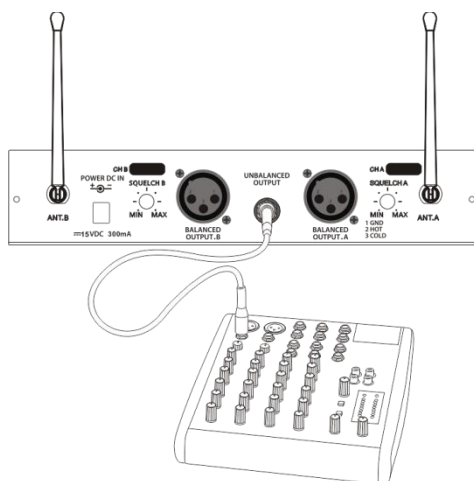

- 05) Press and hold down the **Power/mute switch (16)** to switch the microphone ON.
- 06) Press the **UP/DOWN** buttons on the **display (02)** to choose the available channel. The adjustment range is between 00-99. If you press and hold down the **UP/DOWN** buttons for 8 seconds, you will skip to the previous/next channels without having to press the button each time.
- 07) Press and hold down the **UP/DOWN** buttons for 2 seconds to send the channel information to the microphone.
- 08) For the system to work properly, both – the microphone and the COM-42, should operate on the same channel.
- 09) Talk or sing into the microphone. The AF bar on the **display (02)** will increase and decrease as you keep talking/singing.

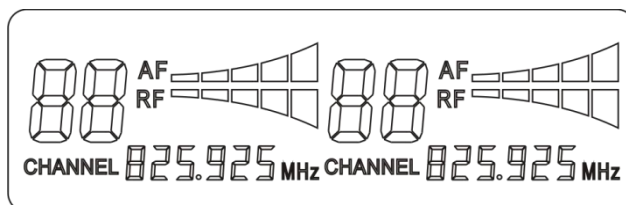

- 10) Adjust the COM-42's **volume control (06, 07)** and the volume adjustment of the connected mixer or amplifier to a suitable level.
- 11) If the performance is over, turn off the sound system and slide the microphone's **Power/mute switch (16)** to the OFF position to save battery power.

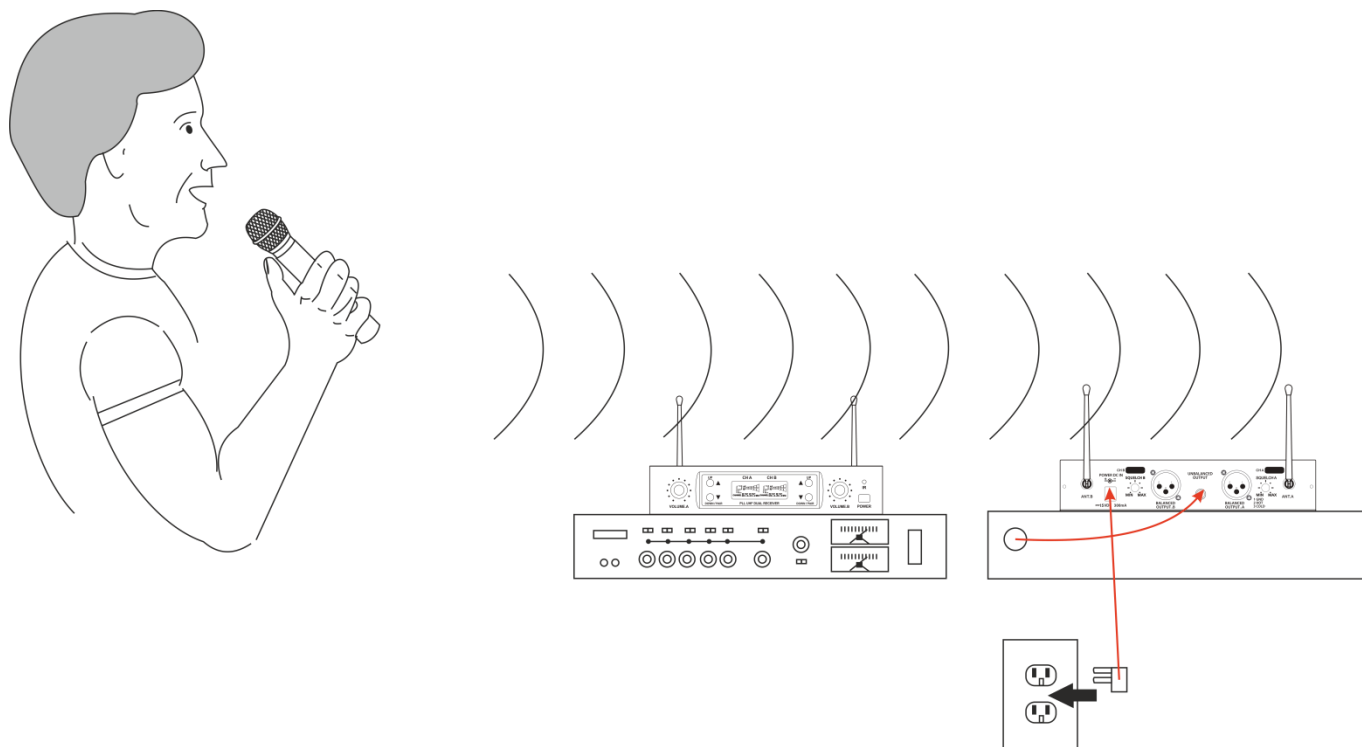

Fig. 04

Inserting/replacing the battery

We recommend powering the microphone by two AA batteries.

- 01) Turn the **battery housing cover (19)** clockwise and remove the cover.
- 02) Open the holder by pressing the **tab** and lifting the **cover (21)**.
- 03) Insert the batteries. Please pay attention to the correct polarity when inserting the batteries.
- 04) Replace the battery cover and gently turn the cover counterclockwise until the battery compartment is closed.

Adjusting the squelch threshold

Interference due to other transmission links can be eliminated as follows:

- 01) Switch off the microphone. The COM-42 should no longer receive any signal.
- 02) If the COM-42 still receives a signal, use the **squelch control (09, 13)** to increase the squelch threshold so that the signal will no longer be received. If the signal cannot be eliminated in this way, set the microphone and the COM-42 to different channels.
- 03) Switch on the microphone again and check if the COM-42 receives the microphone signal.

Note:

If the squelch threshold is adjusted too high, the transmission range will be reduced. Therefore always adjust the squelch control to the lowest possible setting.

Tips for achieving maximum performance

- 01) Keep the distance between the COM-42 antennas and the microphone short as possible.
- 02) Point the COM-42 antennas away from each other, at 45° angle from vertical position.
- 03) Avoid placing the antennas in the vicinity of metal surfaces and obstructions.
- 04) Replace the batteries as soon as you receive low battery alarm.
- 05) If stacking or rack mounting COM-42s in a multiple system setup, do not allow antennas to cross.
- 06) Perform a walk-through before performance or presentation. If dead spots are found, adjust the location of the COM-42. If dead spots remain, mark the dead spots and avoid them.

Connection Cables

Take care of your cables, always holding them by the connectors and avoiding knots and twists when coiling them: This gives the advantage of increasing their life and reliability. Periodically check your cables. A great number of problems (faulty contacts, ground hum, discharges, etc.) are caused entirely by using unsuitable or faulty cables.

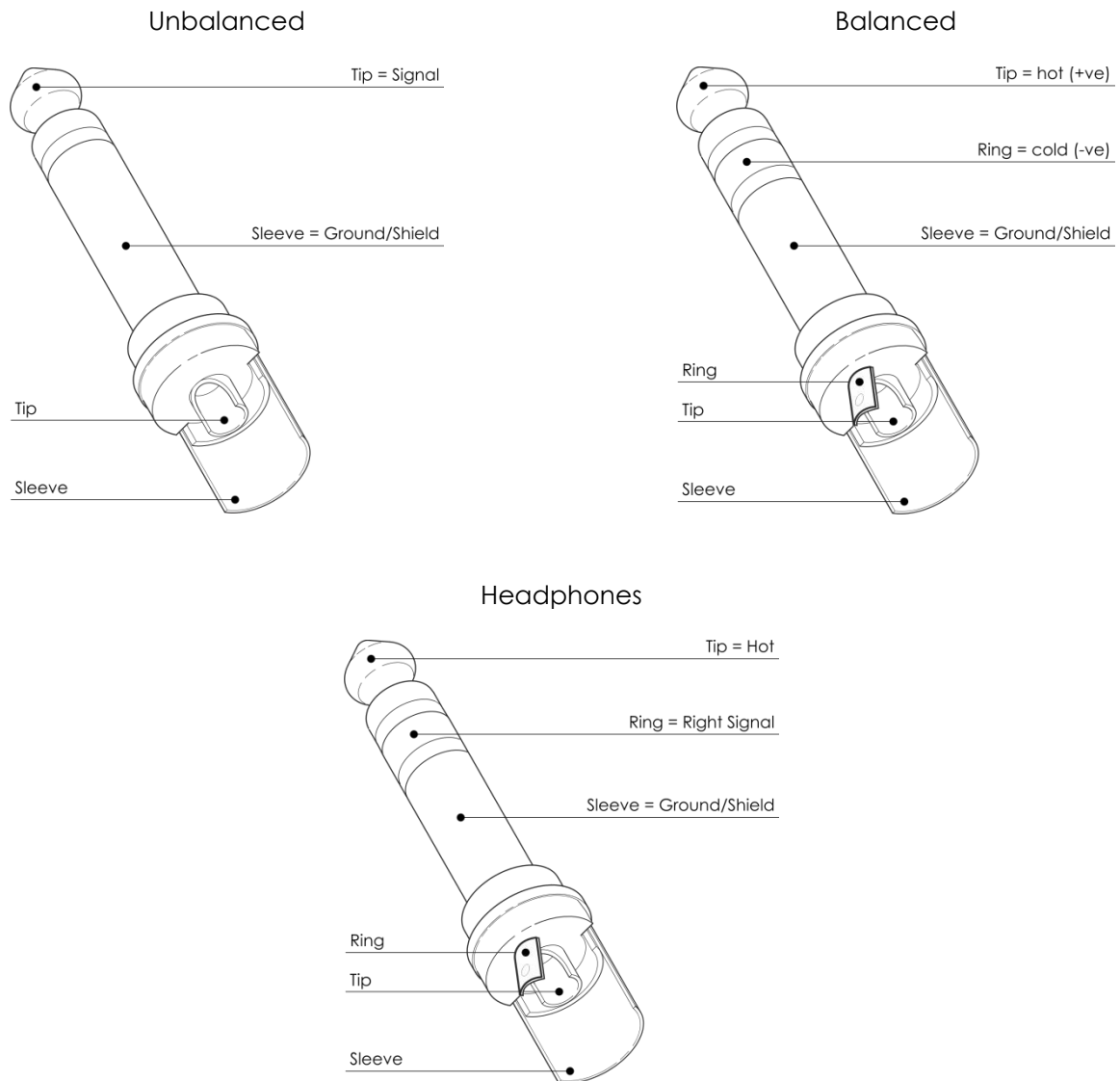

For these applications the unit provides 1/4" TRS and XLR connectors to easily interface with most professional audio devices. Follow the configuration examples below for your particular connection.

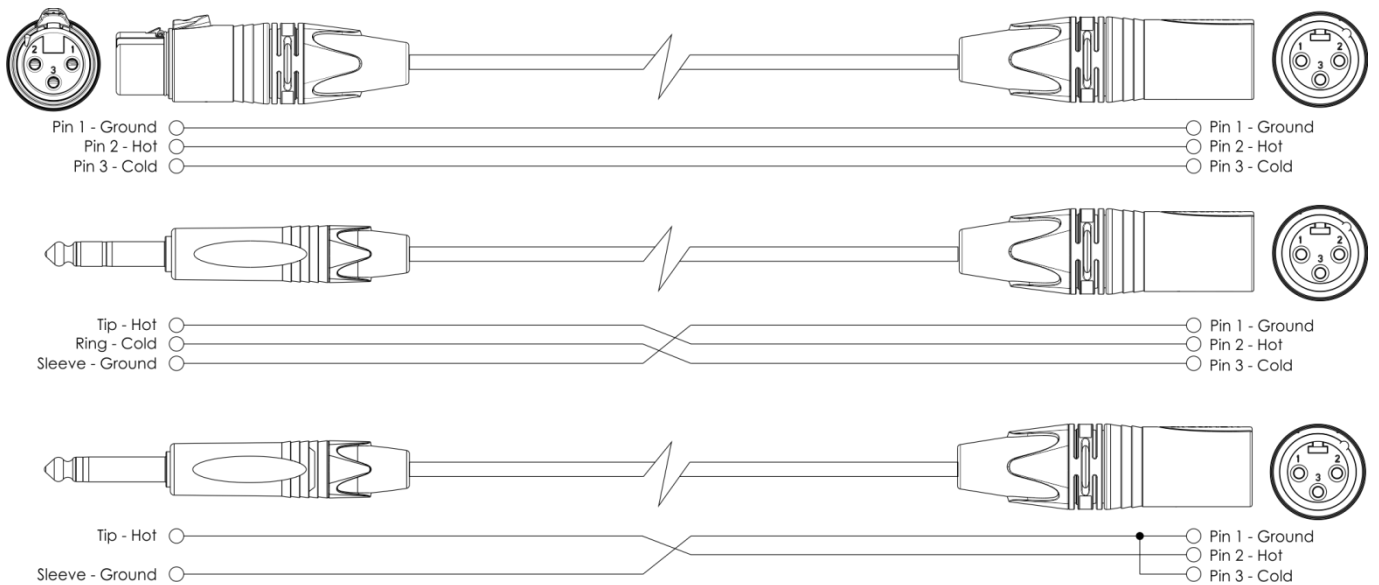

Maintenance

The DAP Audio COM-42 requires almost no maintenance. However, you should keep the unit clean. Disconnect the mains power supply, and then wipe the cover with a damp cloth. Do not immerse in liquid. Do not use alcohol or solvents.

Keep connections clean. Disconnect electric power, and then wipe the audio connections with a damp cloth. Make sure connections are thoroughly dry before linking equipment or supplying electric power.

Troubleshooting

DAP Audio COM-42

This troubleshooting guide is meant to help solve simple problems. If a problem occurs, carry out the steps below in sequence until a solution is found. Once the unit operates properly, do not carry out following steps.

- 01) If the device does not operate properly, unplug the device.
- 02) Check power from the wall, all cables, connections, etc.
- 03) If all of the above appears to be O.K., plug the unit in again.
- 04) If nothing happens after 30 seconds, unplug the device.
- 05) Return the device to your DAP Audio dealer.

Product Specifications

Microphone	
Type:	Dynamic, moving coil
Power supply:	2x Battery UM3, AA1.5V (not included)
Polar pattern:	Cardioid
Dynamic:	>100dBu
Sensitivity (1000 Hz):	2,2 mV/Pa* (*1 Pa = 94 dB SPL)
Max. SPL:	135 dB (1% THD)
Operation time:	>6 hours
Carrier Frequency Range:	606-630MHz
RF Output:	10 mW
Stability:	±0.005%
Frequency Deviation:	±225 kHz
LED Indicator:	Low battery, Power ON/OFF
Accessories:	4 Colour-coded stickers, mini screwdriver
Spurious Rejection:	<-50 dBm
Dimensions:	Ø 50 mm x L 260 mm
Weight:	0,36kg
COM-42	
Type:	Dual receiver, UHF synthesized
Input voltage:	100-240V, 60-50Hz
Power supply:	15VDC, 300mA (adapter included)
Power consumption:	5W
Frequency response:	50-16.000Hz
Dynamic:	>100dBu
Carrier Frequency Range:	606-630MHz
Stability:	±0.005%
Frequency Deviation:	±225 kHz
Display Indicator:	Channel, Frequency, AF & RF
Controls:	Power ON/OFF, Volume, Pair, Up/Down
S/N Ratio:	>100 dB
Dimensions:	210 X 210 x 48 mm (LxWxH)
Weight:	1kg

Dimensions

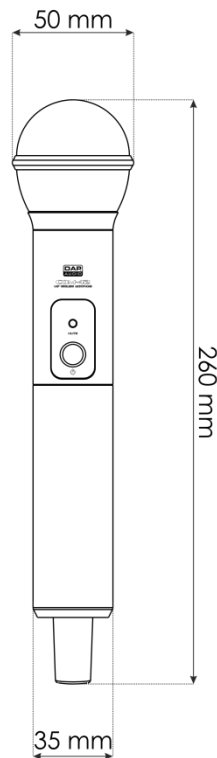
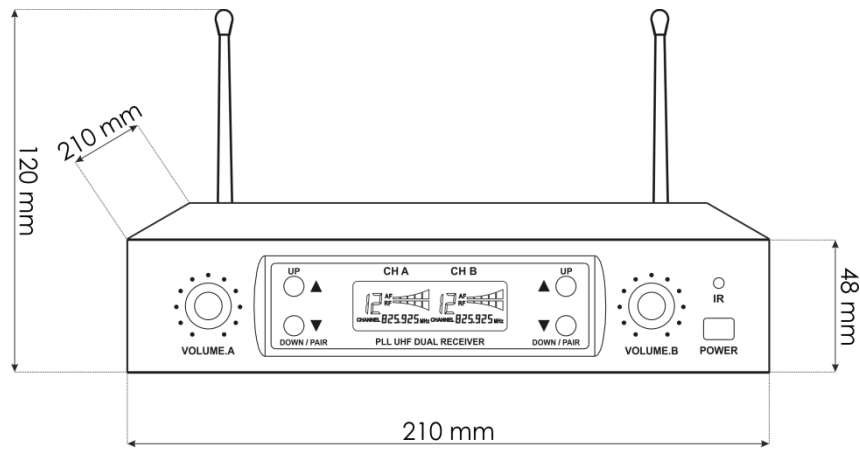

Design and product specifications are subject to change without prior notice.



Website: www.Dap-audio.info
E-mail: service@highlite.com



©2019 DAP Audio