

Big Sky **MX**

USER MANUAL

strymon®

Contents

Features.....	3
Front Panel Controls	4
Footswitches.....	6
Rear Panel I/O and Control	7
Utilizing Single or Dual Reverbs	8
Configuring Param 1 and Param 2 Assignments	12
Working with Presets	13
Configuring the Home Screen.....	13
Navigating Banks and Presets via Footswitches.....	14
Saving Presets	15
Restoring Factory Presets.....	16
Editing Parameters	17
Edited Value Indicators.....	18
Reverb Parameters	19
Common Reverb Parameters	20
Reverb-Specific Parameters.....	22
1+2 Parameters	45
Global Settings	48
Accessing the Global Settings.....	48
The Global Settings Options.....	49
Reset all Global Settings	54
Setting Up an Expression Pedal or Strymon MultiSwitch Plus	55
Configuring the EXP Jack.....	55
Expression Pedal Setup	57
Configuring BigSky MX for MultiSwitch or MultiSwitch Plus	59
Using MIDI	62
Connecting an External MIDI Controller	62
MIDI Program Changes Reference	68
Saving Presets via MIDI	69
MIDI CC Reference.....	70
Factory Default Global Settings	77
Specifications	78
Power Source Requirements	78
Strymon Non-Transferable Limited Warranty.....	79
Safety and Compliance Information.....	80
Legal Notices.....	81

Features

- 12 premium hand-crafted reverbs, including stunningly realistic new algorithms plus expansive enhancements to classic BigSky sounds
- Impulse Response (IR) convolution reverb type with included reverb IRs and support for importing custom IRs
- Single or dual reverb capability per preset, with selectable parallel, series, and split routing options
- High-contrast, multi-view OLED display for simplified editing & preset navigation
- Integrated, IR-based Cab Filter, with several selectable cabs for optional speaker cabinet emulation
- Global Spillover option to persist reverb “trails” across preset changes
- In-depth parameter editing across all 12 reverbs
- Dedicated INFINITE switch for momentary/latching use of Freeze or Infinite function
- Stereo input & output
- High-impedance, ultra-low noise and discrete Class A JFET preamp inputs
- Selectable input level for instrument and line level signals
- Analog dry path for a zero-latency dry signal that is never converted to digital
- +/- 3dB adjustable analog boost or cut, configurable per preset
- True Bypass (electromechanical relay switching) or selectable Buffered Bypass
- Expression pedal functionality allows continuous control over any knob in any direction
- EXP input allows the connection of an optional TRS expression pedal, MultiSwitch, MultiSwitch Plus, or TRS MIDI connection
- 300 preset locations, selectable via encoder, MIDI, or on the fly via footswitch
- Full-featured MIDI capability (Continuous Controller for parameter values, Program Change for bank/preset changes)
- USB-C jack for performing firmware updates, MIDI I/O, and connection to the [Strymon Nixie 2](#) editor software
- High performance 800MHz tri-core ARM processor
- 32-bit floating point processing
- Super low noise, high performance A/D and D/A converters
- Strong and lightweight anodized aluminum chassis
- Designed and built in the USA

Front Panel Controls

REVERB TYPE

Turn the **TYPE** encoder to select the desired reverb type, as indicated by the brightly lit green LED.

Push **TYPE** to configure the use of single or dual reverbs, dual reverb routing, and to select between **Reverb 1** or **Reverb 2** for editing. When dual reverbs are in use, the reverb selected for editing is indicated by the brightly lit green LED surrounding the **TYPE** encoder, and the non-selected reverb type is indicated by the dimly lit green LED. See [page 8](#) for details.

Hold the **TYPE** encoder to rename and save the current preset. See [page 15](#) for details.

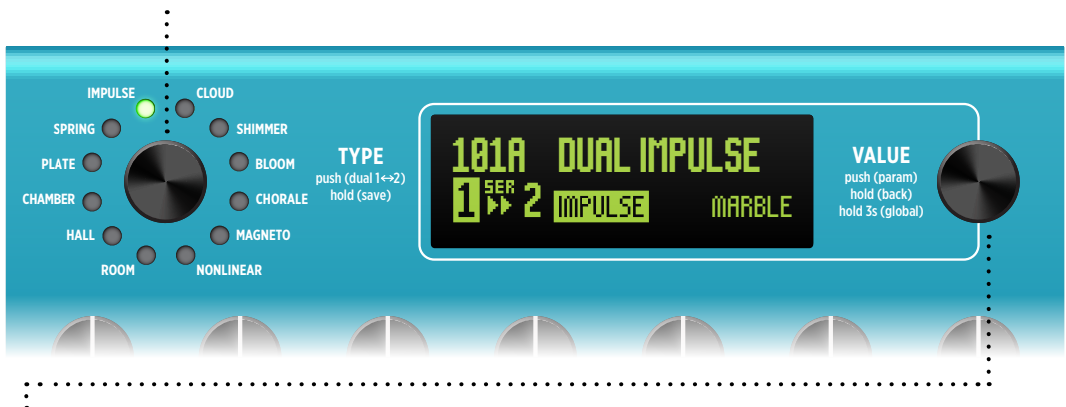

VALUE

From the Home screen, turn to select the next or previous preset location. Optionally, configure the preset navigation to display a scrollable menu list of all 300 preset locations. See for [page 14](#) details.

Push-release to enter the Parameter (**PARAM**) menu to edit parameters for the current reverb. Hold for 1 second to navigate back to the Home screen. See [page 17](#) for details.

Hold for 3 seconds to enter the Global Settings (**GLOBAL**) menu to customize the BigSky MX options. Hold for 1 second to navigate back to the previous screen. See [page 48](#) for details.

TIP! The large, vibrant OLED display offers detailed views for all your actions, as you'll see illustrated throughout this Manual. Much of your time will likely be spent on the **Home Screen**, pictured above, which is also configurable for alternate views—see [page 13](#) for details.

Front Panel Controls

DECAY

Controls the Decay Time of the reverberated signal. The range varies depending on the selected reverb type. For the **NONLINEAR** and **MAGNETO** reverb types, this knob controls the Delay Time.



PRE-DELAY

Adjusts the time between the dry signal and the onset of the reverb, from 0 to 1.5 seconds. For the **NONLINEAR** and **MAGNETO** reverb types, this knob controls the amount of Feedback.

TONE

Adjusts the high-end content of the reverb. Lower settings create darker, warmer reverberation—higher settings are bright and crisp. Set at 12 o'clock for a nicely balanced top end.



MIX

Controls the balance of your analog dry and wet signals, from 100% dry to 100% wet. 50/50 mix occurs when the **MIX** knob is set to 3 o'clock. To completely eliminate the dry signal, see **KillDry** on [page 53](#).

MOD

Adds modulation to the reverberated signal. Lower settings modulate lightly for a subtle and natural movement; higher settings tastefully add stronger modulation.

PARAM 1 / PARAM 2

Assignable to parameters for the current reverb type. To assign, push-release **VALUE** encoder, choose the desired parameter, push-hold **VALUE** while turning a **PARAM** knob. Also, see [page 12](#).

Footswitches

FOOTSWITCHES A & B

Press switch **A** or **B** to engage or bypass the current bank's preset. The switch's LED is lit bright green when its preset is engaged.

Press the **A & B** switches together select a lower bank. Press **B & INFINITE** together to select a higher bank.

NOTE: Configure the Global Settings - **FOOTSW MODE** for **Preset** or **Dual** mode. See [page 51](#) for details.



INFINITE

Hold **INFINITE** for Infinite sustain or Freeze for the current reverb.

NOTE: Select between **Infinite** or **Freeze** sustain options via the **INF MODE** parameter—see [page 21](#).

Also, optionally change the **INFINITE** footswitch's behavior between **Momentary** and **Latching** via the **Inf Latch** parameter—see [page 45](#).

Rear Panel I/O and Control

LEFT IN / RIGHT IN

For mono, connect only the **LEFT IN**. For stereo, connect both the **LEFT IN** and **RIGHT IN**.

LEFT OUT / RIGHT OUT

For mono, connect to only the **LEFT OUT**. For stereo, connect to both the **LEFT OUT** and **RIGHT OUT**.*

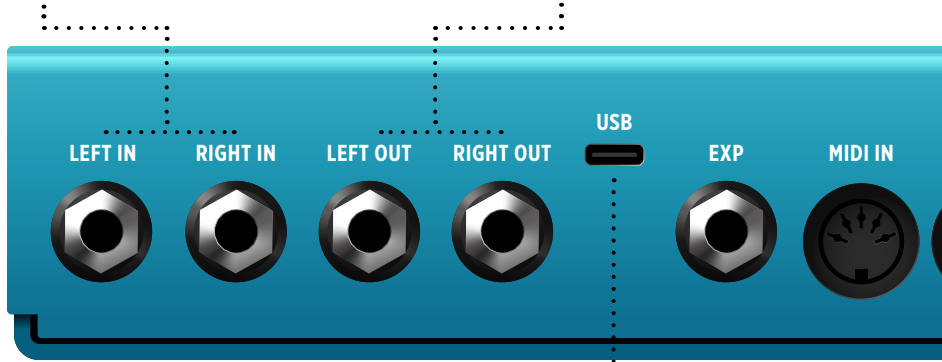

USB

Connect to a computer's USB port for use with the [Strymon Nixie 2](#) application, firmware updates, and MIDI I/O. BigSky MX cannot be powered via USB—use of a 9VDC power source is required (see below).

***NOTE:** When stereo output is in use, BigSky MX is automatically set to Buffered Bypass. See ["Bypass"](#) on page 49.

EXP

Use this multifunction communication jack for external control. Can be configured for use with an Expression Pedal, Strymon Multiswitch, Multiswitch Plus, or TRS MIDI. See [page 55](#).

MIDI IN / MIDI OUT

Connect to a controller or other MIDI gear for MIDI input and output of CCs, Program Changes, and more. See ["Using MIDI"](#) on [page 62](#).

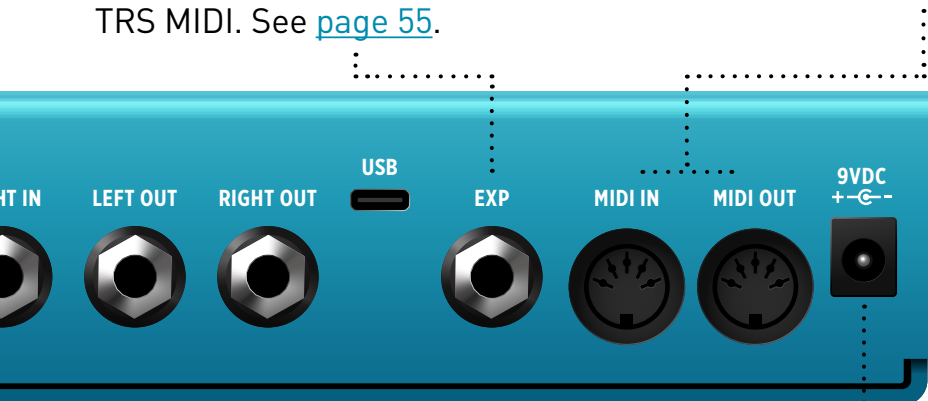

9VDC

Use a power source with the following rating: 2.1mm, center-negative, 9VDC, 500mA minimum (sold separately).

TIP! We recommend the [Strymon Zuma and Ojai](#) advanced power supply units.

Utilizing Single or Dual Reverbs

BigSky MX is able to utilize two reverb types simultaneously within any preset. The Dual Mode settings for the current preset are always shown at the bottom left of the Home screen, and easily accessed via the TYPE encoder.

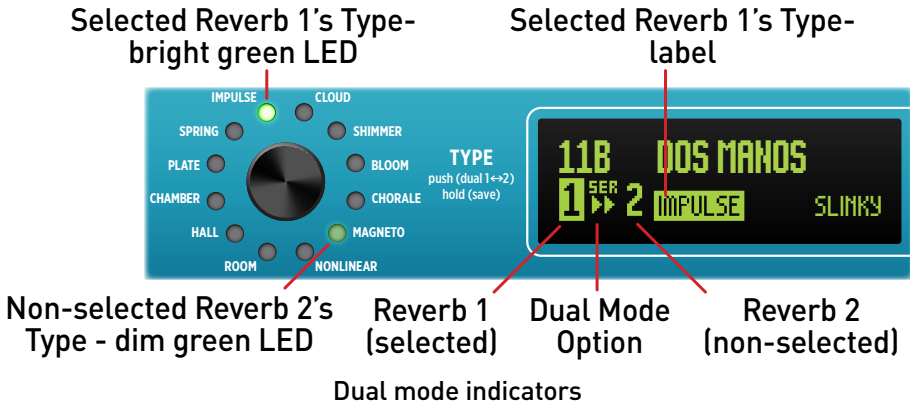

Configuring Dual Mode Options

- On the Home screen, once a preset is loaded, some presets have **Reverb 2** off, with only **Reverb 1** enabled, and some have Dual mode enabled. For all presets, **Reverb "1"** is selected (highlighted) by default, as shown below.



Reverb 2 is off



Dual mode is enabled

- To Select the Dual Mode Option - Simply push-release the TYPE encoder until the Dual Mode routing option flashes to indicate it as being selected for editing. Turn TYPE to choose the desired Dual Mode setting.



Reverb 2 Off - Sets **Reverb 2** off so that the preset utilizes **Reverb 1** only.

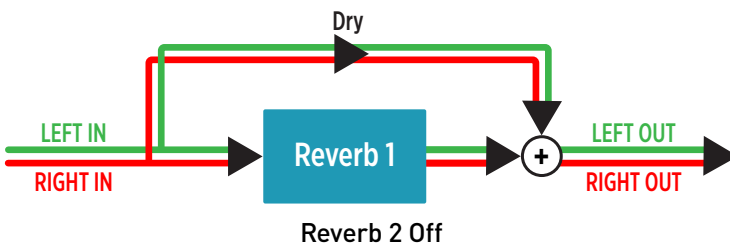



Parallel - Enables two reverbs and routes your input signal separately into each, so that neither reverb affects the other. Note that, when using stereo output, the output of each reverb can be panned left or right independently using the **Pan** parameter. See [page 20](#) for **Pan** details.

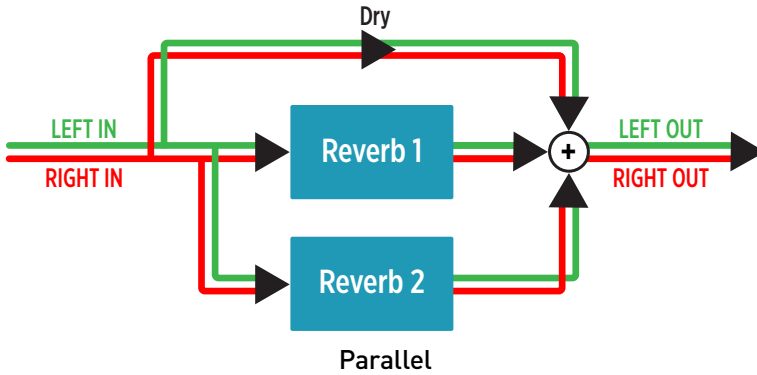

Series 1▶▶2 - Enables two reverbs and routes your input signal first into **Reverb 1** and the **Reverb 1** output into the input of **Reverb 2**. This functionality is the same as running one reverb pedal into another reverb pedal.

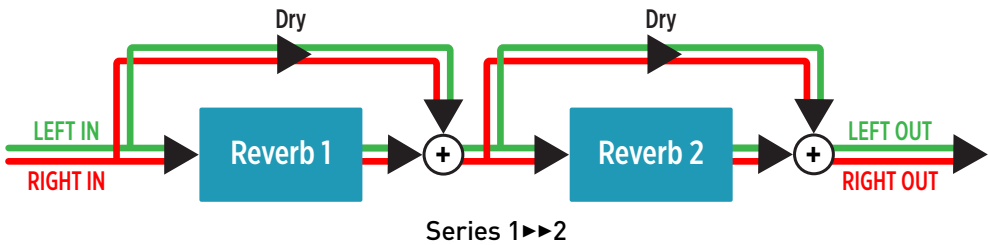

Series 1◀◀2 - Enables two reverbs and routes the input signal first into **Reverb 2** and the **Reverb 2** output into the input of **Reverb 1**. This functionality is the same as **Series 1▶▶2**, except with the order reversed.



Split L|R - Enables two reverbs and routes the input signal separately into each. The **Reverb 1** mono output is routed to the **LEFT OUT** only, and the **Reverb 2** mono output is routed to the **RIGHT OUT** only.

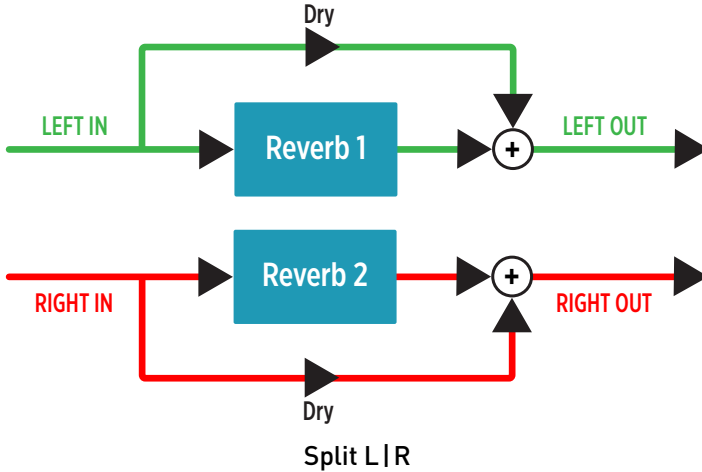

Split R|L - Enables two reverbs and routes the input signal separately into each. **Reverb 1** output is routed to the **RIGHT OUT** only and **Reverb 2** to the **LEFT OUT** only. This functionality is the same as **Split L|R**, but with the outputs reversed.

- 3 To Edit Reverb 1 or Reverb 2 - Push-release the **TYPE** encoder to select the desired reverb “1” or “2” and access its parameters.



Reverb 1 selected



Reverb 2 selected

Once the desired **Reverb 1**, or **2** is selected, turn **TYPE** to choose its reverb type and edit any of the BigSky MX knobs or parameters to customize the preset.

NOTE: Parameters indicated as **1+2** within the **PARAM** menu are applied to *both* reverbs in a Dual reverb preset, regardless of which reverb is selected—see [“Reverb Parameters” on page 19](#).

- 4 Save (push and hold **TYPE**) to retain your settings with the preset—see [“Working with Presets” on page 13](#).

Using Dual Reverbs in your Presets...

All individual **Reverb Parameters** are available and independently editable for each reverb. Try setting **Pan**, **Voice**, **Feedback**, or other parameters differently for each reverb for even larger soundscapes—see ["Editing Parameters" on page 17](#).

When any mode other than **RV2 OFF** is selected, both reverbs are "enabled." Independently adjust the **MIX** knob to determine the amount of each reverb that is added to your signal.

Set the Dual mode to **RV2 OFF** to configure the current preset to use a single reverb (**Reverb 1**) only.

All **1+2 Parameters** within the **PARAM** menu act on *both reverbs simultaneously*—see ["Reverb Parameters" on page 19](#).

Dual - **Series**, **Parallel**, and **Split** routing options are available, with each setting offering different interactions between the two reverbs and distinctive stereo output behaviors—see ["Configuring Dual Mode Options" on page 8](#).

Optionally, configure the **Footsw Mode** Global Setting so that footswitches **A** and **B** independently toggle each reverb as enabled/disabled—see [page 51](#).

Several factory presets that utilize Dual reverbs and different routing options are already provided on BigSky MX. Give them a try as starting points and feel free to experiment.

Configuring Param 1 and Param 2 Assignments

Configure the **PARAM 1** & **PARAM 2** knobs to each provide quick access to the desired **PARAM** menu parameter of the currently active reverb type.* By default, each reverb already includes assignments for both the **PARAM 1** & **PARAM 2** knobs. For example, with the Cloud reverb, the **Low End** parameter is assigned to **PARAM 1** to allow for easier control over the reverb's low frequency content. Customize the **PARAM 1** & **PARAM 2** knob assignments for any reverb type using the following steps. Your customized **PARAM 1** & **PARAM 2** knob assignment are automatically stored per reverb type.

- 1 With the desired reverb type selected, push the **VALUE** encoder to enter the **PARAM** menu. (Note that if the current preset includes dual reverbs, push the **TYPE** encoder to select **Reverb 1** or **2** for editing—[page 8](#).)

Turn **VALUE** to choose the parameter to be assigned.



Opening and navigating the Parameter (PARAM) menu

***NOTE:** You can select any parameter within the menu, with the exception of the **1+2 EXP Setup**, **1+2 Copy From**, or the Impulse reverb type's **Impulse** parameter for assignment to **PARAM1** or **PARAM2**. For the assignment of any other "1+2" type parameter, adjusting the **PARAM** knob will adjust the parameter on both reverbs simultaneously within a Dual reverb preset.

- 2 Push and hold the **VALUE** encoder and immediately turn the **PARAM 1** (or **PARAM 2**) knob to assign it. "**ASSIGNED**" appears on the display to indicate the knob assignment was successful.

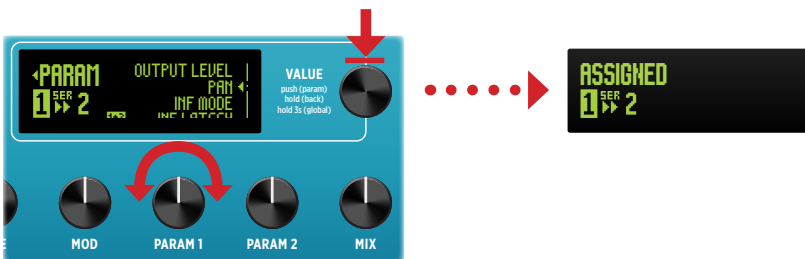

Assigning a parameter to the PARAM1 knob

- 3 If your preset utilizes Dual reverbs, repeat the previous steps with the opposite **Reverb 1** or **2** selected to customize its **PARAM** knobs as desired.

Working with Presets

BigSky MX includes 150 banks with A and B preset locations within each bank. Banks are numbered 0 to 149 on the display. As shown on [page 6](#), banks and presets can be selected using footswitches **A** and **B** or, when viewing the Home Screen, by simply turning the **VALUE** encoder to access and load presets.

NOTE: BigSky MX includes 100 factory presets, which are stored within the 00A-049B preset locations. Preset locations 050A-149B are populated with a "Blank" preset and default settings.

Configuring the Home Screen

Upon power up of BigSky MX, the Home Screen is displayed, which provides details about the current preset. Global Settings allow the Home Screen display and Preset Navigation to be configured to optimize BigSky MX for the preferred environment and workflow.

To select the preferred Home Screen and Preset Navigation settings:

- 1 Push and hold the **VALUE** encoder for 3 seconds to enter the Global Settings (**GLOBAL**) menu (also, see [page 48](#)), select **Home Screen**, and then select one of the three view options: **Default**, **Stage**, or **Stage Alt**.



Configuring the Global Settings - Home Screen option

- **Default** shows the most detailed preset information, including the preset location and name, Cab Filter "enabled" indicator (see [page 50](#)), Dual mode setting, selected Reverb Type, and Decay value.*

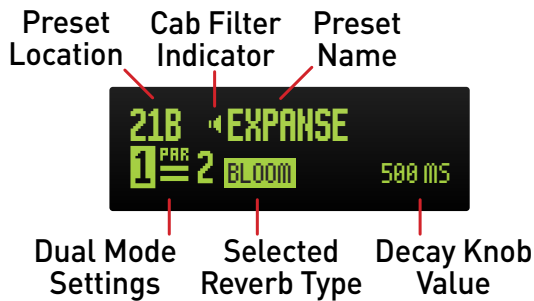

The Home screen (Default view)

***NOTE:** When the Impulse reverb type is selected, the name of the IR file that is currently selected (from within the **PARAM - Impulse** menu) is shown rather than the Decay knob's ms value at the bottom right.

- **Stage** shows the current bank/preset location and the first several characters of the preset name in large letters, more suitable for live use.



Stage Home Screen

- **Stage Alt** is similar to **Stage**, as shown above, but if the preset name is longer than what fits on the screen, the screen will scroll to display the full name.

NOTE: The screen will dim after no control is touched for 15 minutes. Additionally, a screensaver will automatically scroll the preset name every few seconds after no audio is detected by the pedal for an hour.

- 2 Push **VALUE** to step back to the **Global Settings** menu, select **Preset Nav**, and then choose the desired Home Screen preset navigation type: **Direct** or **List**.

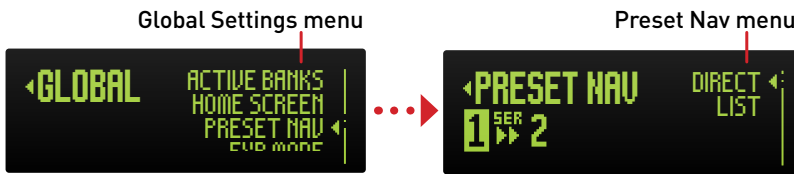

Choosing the Preset Navigation option

- **Direct** (default setting) navigates directly to the next/previous presets when turning **VALUE**. The Home Screen displays the current preset.
- **List** displays a preset menu list when turning **VALUE**. Navigate the menu list by turning **VALUE** to select and queue a preset, then push **VALUE** to load the preset.



The Preset menu list

Navigating Banks and Presets via Footswitches

As covered in the preceding "[Footswitches](#)" section, press BigSky MX's footswitches **A** and **B** simultaneously to select the previous bank, or **B** and **INFINITE** for the next bank. The queued bank's **A** and **B** preset names are shown on the display for reference. Pressing either footswitch **A** or **B** from this screen will then load the respective preset.



The selected bank screen

TIP! Optionally, utilize a Strymon MultiSwitch Plus or MIDI for bank and preset selection—see [page 59](#).

Saving Presets

Once you've dialed in all the knobs and parameters for the current preset, be sure to **Save** and optionally rename the preset to retain all settings. You can save to the current preset location or to any of the 300 preset locations within the BigSky MX memory. The first 100 presets come loaded at the factory and are recoverable with a factory reset (see the next page).

NOTE: The bypass state is also stored and recalled with the saved preset, so be sure to toggle the footswitch to the desired state before saving.

To Save your settings to a preset:

- 1 Push and hold the **TYPE** encoder for two seconds to enter the Save screen.

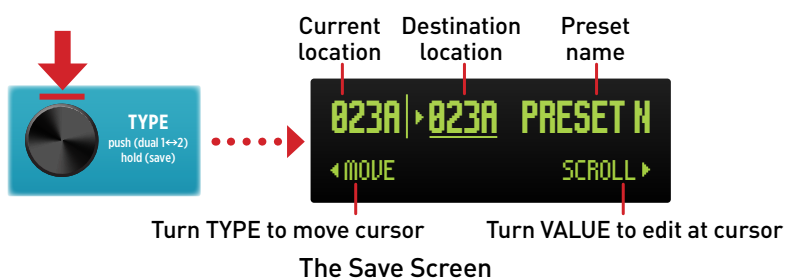

- 2 To save to the current location, skip to **step 3**. Optionally, turn **TYPE** to select a different preset location or to select individual name characters to edit the preset name before saving—the selected item is indicated by the flashing arrow and underline cursor.

- Turn **TYPE** clockwise to **move** the edit cursor to the destination preset number. Turn the **VALUE** encoder to **scroll** to the desired preset save location (000A - 149B).



Editing the preset save location

- Turn **TYPE** clockwise to **move** the edit cursor to select any preset name character. Turn the **VALUE** encoder to **scroll** through and select a replacement character. Repeat to edit all name characters.



Editing the first character of the preset name

- 3 Once all desired changes are made, press and release the **TYPE** encoder. **SAVE COMPLETE** will appear on the screen, indicating the preset is saved, overwriting the previous preset within the selected location.

TIP! You can also save presets via MIDI—see [page 69](#).

Restoring Factory Presets

Performing the Reset Presets action restores all BigSky MX factory presets.

CAUTION! This procedure will erase custom presets saved in BigSky MX. Before proceeding with the following steps, it is recommended that you first use the free [Strymon Nixie 2](#) application to backup all your BigSky MX presets and settings.

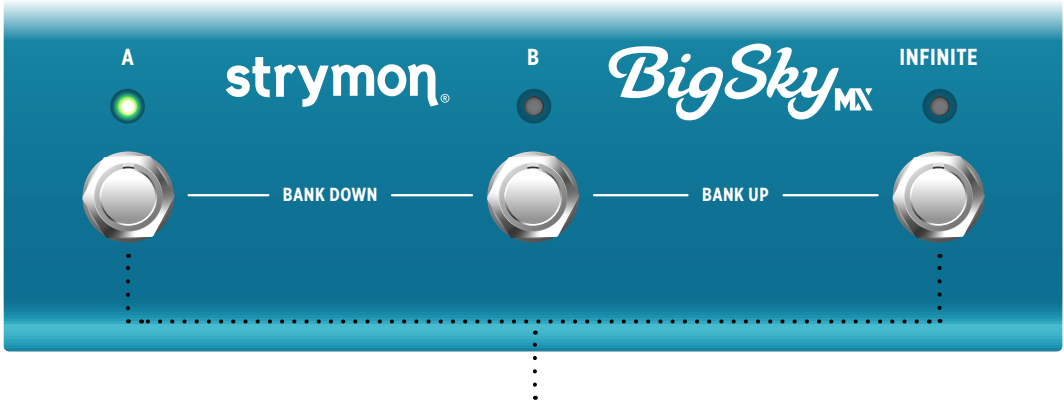

- 1 With BigSky MX currently powered off, press and hold both the **A** & **INFINITE** footswitches while connecting the power source—keep holding the footswitches until the **RESET PRESETS - DO NOT TURN OFF** message appears, then release the footswitches.

**RESET PRESETS
DO NOT TURN OFF**

The Reset message screen

- 2 BigSky MX will power cycle itself. Once BigSky MX has powered back on, it is ready for use.

TIP! Alternatively, you can hold all three footswitches during power up to perform a complete **FACTORY RESET**, which will restore all factory presets, all factory Impulse Response (IR) files, and all Global Settings defaults.

Note that a complete Factory Reset will delete all your custom presets and any imported IR files from the device memory. Use the [Strymon Nixie 2](#) application to make a backup of all presets and Global Settings *before* performing a reset. (Note that IR files are not included in a backup.)

As another alternative, you can perform a reset of only your Global Settings—see [page 54](#).

Editing Parameters

Enter the Parameter (PARAM) menu to access and edit all **Reverb Parameters** and dual **1+2 Parameters** for the current preset using the following steps:

- 1 If the current preset includes dual reverbs, start by selecting **Reverb 1** or **Reverb 2** for which you want to edit—Push the **TYPE** encoder to select **Reverb “1”** or **“2.”** (Also, see [“Utilizing Single or Dual Reverbs” on page 8.](#))

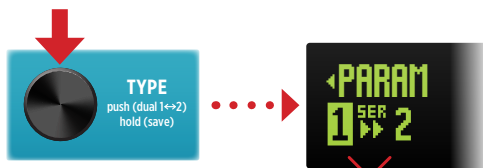

Reverbs 1 and 2
(1 is selected)

Push TYPE to select between Reverb 1 and 2

- 2 Push and release the **VALUE** encoder to enter the Parameter (PARAM) menu. In this example, the **Cloud** reverb type (**Reverb 1**) is selected.



The PARAM menu screen is displayed (Diffusion is selected)

- 3 Turn **VALUE** to choose the parameter from the menu list, then push and release **VALUE** to access the selected parameter’s slider or other options.

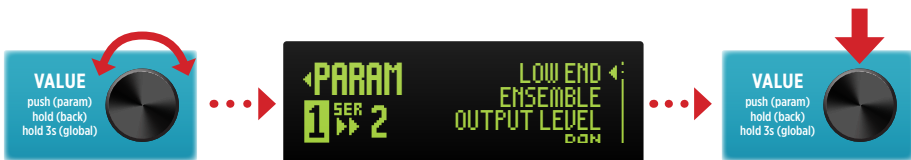

Selecting a parameter (Ensemble is selected)

The first several **Reverb Parameters** in the menu list are specific to the currently-selected reverb type—see [page 19](#).

1+2 Parameters are available for all reverb types and appear in the **PARAM** menu indicated with a **1+2** symbol. 1+2 Parameters are “shared” and affect both reverb types within a Dual reverb preset—see [page 19](#).

- Turn **VALUE** to adjust the parameter’s slider or, if presented with a menu list of options, turn **VALUE** to select the desired option and push **VALUE** to access the parameter options.



Adjusting a parameter (Ensemble slider)

- Once edits are complete, push and release **VALUE** to exit the parameter settings and step back to the **PARAM** menu screen, then push and hold **VALUE** for 1 second to return to the **Home Screen**.

Edited Value Indicators

Whenever a preset’s knob or parameter value has been changed, the currently lit **A** or **B** footswitch LED will change color from bright **GREEN** to **AMBER** to indicate that the preset is currently in an edited state.



Saved state (green)



Edited state (amber)

Additionally, for all “menu” and “slider” type parameters, an outline arrow symbol appears indicating the last-saved value for reference.*

***NOTE:** The following parameter indicators will not appear if you have changed the Reverb Type from the last-saved Reverb within the preset—until you save the preset again with the new Reverb Type.

Menu type parameters display an outline arrow to the right of the preset’s currently-saved option within the menu list:



A menu parameter’s saved option indicator arrow (Infinite Mode parameter)

Slider type parameters display an outline arrow below the slider bar to indicate the preset’s currently-saved value:



A parameter slider’s saved value indicator arrow (Ensemble parameter)

Reverb Parameters

Within the Parameter (**PARAM**) menu are numerous settings for shaping and sculpting each reverb. There are three types of parameters within the menu:

- **Common** - There are four parameters that appear within the menu regardless which reverb type is currently selected: **Low End**, **Output Level**, **Pan**, and **Inf Mode**. These parameters are applied only to the currently-selected reverb type. Common parameters are covered on [page 20](#).
- **Reverb-Specific** - Several parameters that appear in the menu are specific to the currently-selected reverb type. Reverb-Specific Parameters are described in the individual Reverb Parameter sections, starting on [page 22](#).
- **1+2 Parameters** - Last in the menu list for all reverb types are several “shared” parameters, indicated with a **1+2** symbol, which are applied to both reverb types when the Dual Mode is enabled. All 1+2 Parameters are covered on [page 45](#).



The PARAM menu

Settings made for all parameters are stored individually per preset—be sure to **Save** (see [page 15](#)) after editing any parameters to retain your settings.

Common Reverb Parameters

The following parameters are available within the **PARAM** menu for all reverb types. Settings made for these parameters are editable individually per reverb type.



The Parameters menu - the common reverb parameters

NOTE: If the current preset includes dual reverbs, push the **TYPE** encoder to select **Reverb 1** or **2** to display and edit its Common and Reverb-Specific parameters. Also, see ["Utilizing Single or Dual Reverbs" on page 8](#).

Common Reverb Parameter	Values	Description
<p>Low End</p>		<p>Affects the low frequency content and decay profile. As increased in value, more low frequencies reverberate creating the impression of larger spaces.</p> <p>Results for the adjustment of Low End can vary among reverb types. Please refer to the notes in the following individual Reverb-Specific parameter sections for details.</p>
<p>Output Level</p>		<p>Attenuates the volume level of the individual reverb type's wet signal only, which may be useful to fine-tune the wet-dry mix of some presets.</p>
<p>Pan</p>		<p>Pans the wet signal to 100% LEFT OUT or RIGHT OUT or anywhere in between to modify the width of your stereo spread.</p> <p>NOTE: When connected to only BigSky MX's LEFT OUT, or when using SPLIT L R or SPLIT R L - DUAL routing modes, the Pan control becomes disabled and is automatically set to center for optimal mono output.</p>

Common Reverb Parameter	Values	Description
Infinite Mode 	Freeze Infinite Off	<p>Sets the mode for the INFINITE footswitch:</p> <ul style="list-style-type: none"> • Freeze - Play a note or chord, then press and hold the footswitch to capture and sustain the reverb applied to your signal indefinitely while the footswitch is held.* As you play new notes/chords while still holding the footswitch, you'll hear them on top of your "frozen" signal <i>without</i> being added to the reverb. • Infinite - Press and hold the footswitch to hear reverb applied indefinitely to <i>all</i> input signals while the footswitch is held.* • Off - Disables the Infinite/Freeze function. <p>*NOTE: Use the Inf Latch 1+2 Parameter to configure the switch's behavior between Momentary (the default) or Latched—see page 45].</p>

NOTE: For the **Output Level**, **Pan**, and **Inf Mode** parameters, your current edited setting persists when changing the reverb type.

Reverb-Specific Parameters

Each reverb type includes its own set of unique parameters that are displayed and applied only to the individual reverb type that is currently selected. The following are descriptions for all Reverb-Specific parameters, listed per reverb type.



NOTE: If the current preset includes dual reverbs, push the **TYPE** encoder to select **Reverb 1** or **2** to display and edit its parameters. Also, see ["Utilizing Single or Dual Reverbs"](#) on page 8.

Room Reverb

BigSky MX Room algorithms create intimate environments ranging from well-tuned studio ambience to larger nightclub acoustics. The Tone knob, Diffusion, and Low End parameters adjust the damping and scattering effects of room materials, furniture, and people.



The Parameters menu (Room reverb type is selected)

ROOM Parameter	Values	Description
Size 	Studio Club	Offers a choice between two room type algorithms. Note that the characteristics of the selected Studio or Club reverb differ depending upon the Voice parameter's MX or Classic selection (see the Voice description below): <ul style="list-style-type: none"> • Studio - A well-tuned intimate studio environment. • Club - A larger, livelier “nightclub” experience.
Diffusion 		Softens the early reflections to create a thicker, more diffused reverb at the attack portion of the reverb. Sometimes this can be more easily “felt” than heard, depending on the input and specific settings. Adjust to higher values to apply more diffusion.

ROOM Parameter	Values	Description
Voice 	MX Classic	Offers a choice between two Room voicings, which specifically affect the currently-selected Studio or Club - Size parameter as described below (also, see the preceding Size description): <ul style="list-style-type: none"> • MX <ul style="list-style-type: none"> • Studio – A rich, dense room with a smooth response and a quickly damped top end for ultimate realism. • Club – Lengthened internal parameters create a larger space with a similar tonal response as Studio. • Classic <ul style="list-style-type: none"> • Studio – Lower density and mild high-end damping for a lively reflective experience. • Club – lengthened internal parameters create a larger space with a similar tonal response as Studio.

Using the Room Reverb...

For realistic acoustic spaces, Pre-Delay can be kept at minimum, with Decay values in the 500ms to 2 second range. However, the Room algorithm is designed to be just as adept at long decay times. For great atmospheric reverbs, try Pre-Delay at noon, Decay at 12 seconds or more, and Mod at 1 o'clock. Mix to taste.

Add modulation for subtle movement at low settings or more overt yet tasteful modulation at higher settings.

Hall Reverb

Diffused reflections and slower-building density are the hallmarks of this beautiful and versatile reverb. The Concert size is well-balanced, spacious, and warm, while the Arena size is huge, enveloping, and booming. The Mid parameter allows for precise EQ tailoring of the reverberated sound.



The Parameters menu (Hall reverb type is selected)

HALL Parameter	Values	Description
Midrange 		Affects the midrange frequency content of the reverb. Turn up to emphasize the mid frequencies, or use lower values to reduce the mids. Set half-way for a flat midrange response.
Size 	Concert Arena	Offers a choice between two Hall types. The early reflection buildup and late reverb decay profile change accordingly. Note that the characteristics of the selected Concert or Arena algorithm differ depending upon the Voice parameter's MX or Classic selection (see the following Voice description): <ul style="list-style-type: none"> • Concert - A well-balanced and warm concert hall auditorium. • Arena - The acoustics of the largest enclosed venues.
Swell Rise 		Selects the rise time for the swell effect, with longer swells as the value increases. At 0, there is no swell effect.
Swell Type 	Swell Wet Swell Dry	Determines the type of signal introduced with the Swell effect: <ul style="list-style-type: none"> • Swell Wet - Swells in the reverberated signal behind the dry signal. • Dry - Swells the dry signal into the reverb.

HALL Parameter	Values	Description
Voice 	MX Classic	Offers a choice between two different Hall voicings, which specifically affect the currently-selected Concert or Arena - Size parameter: <ul style="list-style-type: none"> • MX <ul style="list-style-type: none"> • Concert – A naturally rich and smooth buildup of early reflections, and a decay with minimal structural resonance for the ultimate in realism. • Arena - A spacious, well-tuned larger venue with a prominent late reflection from the structure's back wall. • Classic <ul style="list-style-type: none"> • Concert - An even profile of early reflections, with generous low damping and soft diffusion. • Arena – A mega structure with a booming low end and slow buildup to maximum density.

Using the Hall Reverb...

Adding some Pre-Delay can increase the sense of physical space and further separate the reverb from the dry signal. For a balanced, versatile hall sound that will complement just about any input source and style, Try the Concert Size with a Decay of about 3.5 seconds, the Tone at 12 o'clock, and Low End parameter centered.

For realistic, huge spaces, choose the Arena Size with a 10 second decay or longer and increase the Low End parameter. Keep the Mix control below 12 o'clock to keep you centered on stage, or use higher mixes to become an audience member listening to the wash of reverberation along with the dry signal.

Chamber Reverb

A generous and dense medium room-sized reverberation with excellent focus and clarity. The selectable Color options capture the effect of speakers and mics used in the chamber recording process.



The Parameters menu (Chamber reverb type is selected)

CHAMBER Parameter	Values	Description
Color	Neutral Clear Smooth Crisp Deep	<p>Several options are offered which affect the overall tonality and character of the Chamber reverberation:</p> <ul style="list-style-type: none"> • Neutral – Exhibits a wide-range, flat response for a natural reverberation tone. • Clear – Reduces low end response to avoid muddiness with a bass-heavy source signal. • Smooth – Reduces mid-frequency response, reminiscent of a “smile” EQ curve. • Crisp – Exhibits a high-passed response, for a very bright reverberation. • Deep – Emphasizes mid-frequencies for a reverberation with vocal qualities.

Using the Chamber Reverb...

When the sound of a Room type reverb is just not quite reflective enough, but a Hall or Arena is too large, the Chamber type may just be the choice to add some depth.

The Chamber can be useful on just about any instrument or even vocals. Choose one of the Color options to best suit the desired reflection tonality.

For the mildest reverberation, try the Neutral Color option with lower Decay and Mix values to place your instrument in a medium sized room environment.

Try the Clear option and higher Decay and Pre-Delay for more dramatic reflections.



The Smooth, Crisp, and Deep options, much as their names imply, offer different shades of bottom and top end to allow the reverberations to blend further in the background or come forward more brightly in the mix.

Plate Reverb

The Plate is a rich, fast-building reverb that creates depth without early reflection cues to a specific environment. The Tone knob and Low End parameter are simple but powerful frequency-shaping tools



The Parameters menu (Plate reverb type is selected)

PLATE Parameter	Values	Description
<p>Size</p> 	<p>Small</p> <p>Large</p>	<p>Offers a choice between two plate sizes. Note that the characteristics of the selected Small or Large algorithm differ depending upon the Voice parameter's MX or Classic selection (see the following Voice description):</p> <ul style="list-style-type: none"> • The Small plate is representative of a “home project” plate. • The Large plate is a traditional studio plate.
<p>Voice</p> 	<p>MX</p> <p>Classic</p>	<p>Offers a choice between two different Plate voicings, which specifically affect the currently-selected Small or Large - Size parameter:</p> <ul style="list-style-type: none"> • MX <ul style="list-style-type: none"> • Small - A nicely balanced response with a smoother top end. Like an analog plate, offers reduced headroom and subtle tube saturation. • Large - Like an ideal digital plate, offers an immediate buildup up to maximum density with minimal coloration. • Classic <ul style="list-style-type: none"> • Small – A splashy, ringy reverb with reduced low end. • Large - A lush, smooth reverb with less “zing” compared to the MX voice.

Using the Plate Reverb...

The undamped Decay time of traditional large plate reverbs is about 5 seconds. Large baffles were positioned close to the plate to damp the vibrations for shorter reverbs as required. Try short decays around 1.5 seconds with lower Mix values to add some subtle ambience to dry tracks. Long decay times can go beyond physical limitations to create clear ambient pads of reverb.

Plate reverbs were routinely run through a post EQ to tailor the low end to sit properly in the mix, and to reduce less pleasant high frequency ringing. The Low End parameter's wide range is voiced for maximum flexibility, while the Tone knob adjusts the high end from unfiltered full-bandwidth (max) to warm (noon) to dark and damped (min).



Add some Modulation to inject a subtle sense of movement and increased dimension to the reverb.

Spring Reverb

The standalone spring tank became a staple of surf and spaghetti-western music that developed in the '60s. The Spring reverb allows for complete customization from warm and mellow to splashy and dripping with its Tone and Mix Controls, Dwell parameter, and selectable number of springs.



The Parameters menu (Spring reverb type is selected)

SPRING Parameter	Values	Description
Dwell 	Clean Combo Tube Overdrive	Adjusts the amount of drive in the spring tank preamp circuit: <ul style="list-style-type: none"> • Clean - The cleanest spring tones. • Combo - Adds more gain, as is typical in combo amps with onboard spring reverb. • Tube - An increase in both the gain and the amount of harmonic components entering the spring tank, like turning up the Dwell control in an outboard spring reverb unit. • Overdrive - Expands the preamp gain for maximum trashiness.
Number of Springs 	1 Spring 2 Springs 3 Springs	Allows selection of 1, 2, or 3 Springs in the spring tank. Increasing the number of springs adds complexity due to the interaction of the different delay times of each individual spring.
Voice 	MX Classic	Offers a choice between two different Spring voicings: <ul style="list-style-type: none"> • MX – The quintessential spring tank, dripping with authenticity and splashy dynamic response. • Classic – A lively spring with plenty of bounce and rattle.

Using the Spring Reverb...

For traditional combo amp tones, use the 2 Spring - Number parameter option with the Combo - Dwell setting and a Decay value of around 4.5 seconds. Many combo amps have a darker spring tone, so try rolling the Tone knob back to mellow out the reverb. Try lowering settings on the Low End parameter to reduce the low frequency content as well.

For more sophisticated spring reverbs, try the 3 Spring reverb with Clean Dwell settings and shorter decay times of around 3 seconds. Keep the Low End parameter at the half-way point and adjust the Tone knob to taste.

For maximum splash, crank the Tone knob to maximum and turn the Low End parameter to minimum. Turn up the Mix to 3 o'clock if you're bold.

Hot input signals will drive the spring harder. Reduce the Dwell setting if you experience too much spring distortion.

Adjusting the Low End parameter to 50% and less attenuates the lows to avoid rumble and feedback issues. Increasing the Low End can add some richness to the spring when using the Clean or Combo Dwell settings and lower Mix levels.

Impulse Reverb

This convolution reverb utilizes Impulse Response (IR) files to create mathematically perfect recreations of recorded spaces. A variety of IRs is included, selectable from the Impulse menu. The Impulse reverb can be shaped and customized even further using the provided parameters. Optionally, load your own reverb IRs using the free Strymon Nixie 2 app.







The Parameters menu (Impulse reverb type is selected)

NOTE: When a new Impulse is loaded, all controls except **MIX** are reset to the following default settings:

- DECAY - 100%
- PRE-DELAY - 0
- TONE - 50%
- MOD - 0
- LOW END - 50%
- FEEDBACK - 0
- ATTACK - 0
- DIRECTION - Forward
- STRETCH - 1.0
- TAIL - Envelope

IMPULSE Parameter	Values	Description
Impulse Select 	Factory folder	Opens the Impulse file menu. Push VALUE then select from the folder of Factory of IRs. TIP! Manage the existing Impulse list and import reverb IRs from your own collection using the Nixie 2 software—see page 33 .
Attack 		Determines the timing of the onset of the reverberation.
Stretch 		Re-samples the Impulse Response to change both the inherent decay time and frequency content. Use low settings to reduce the decay and higher settings for longer decays.

IMPULSE Parameter	Values	Description
Tail 	Envelope Gate	Offers a choice of two different types of shaping for the decay tail of the reverb: By default, Impulses are loaded at full DECAY (100%), which effectively does not apply a Tail shape. With DECAY values less than 100%, the Tail function is applied to the Impulse Response. <ul style="list-style-type: none"> • Envelope - Applies a decreasing ramp function to the Impulse to shorten the length based on the DECAY setting. • Gate - Abruptly truncates the impulse based on the DECAY setting.
Direction 	Forward Reverse	Sets the direction of the reverberation: <ul style="list-style-type: none"> • Forward - A standard reverb decay. • Reverse - A backward reverb decay is heard following your input signal.
Feedback 		Affects the amount of wet signal fed back into the Pre-Delay for added reflections and ring. The sound achieved with Feedback is very dependent on the position of the Pre-Delay knob.

Using the Impulse Reverb...

The ability to load IR files provides a virtual endless number of options for reverb explorations, from traditional spaces to real and imaginary environments.

Enter the Impulse parameter's menu to choose from among the selection of included Factory IR files. (Also, see ["Importing and Managing IRs with Nixie 2..."](#) below.)

Unlike with many simple "IR Loader" units, BigSky MX's knobs and additional parameters provide you with a bevy of added options to further adjust and enhance the loaded IR. Simply use the knobs for traditional control of Decay, Pre-Delay, Mix, etc. Dive into the PARAM menu to utilize some of the less traditional options and enhancements, such as Tail, Direction, or Stretch.

- Choose the Tail parameter's Envelope or Gate to alter the sonic shape of your IR decay.
- Change any IR reverb to a "backward" effect by selecting the Reverse Direction option.
- Utilize the Stretch parameter to lengthen or shorten the IR's inherent decay tail as desired.

Importing and Managing IRs with Nixie 2...

Download the free [Strymon Nixie 2 application](#) for macOS or Windows[®] computers to allow you to import 3rd-party reverb IR files, expand, and manage BigSky MX's onboard Impulse library. To use **Nixie 2**:

- Connect BigSky MX to your computer's USB port and launch Nixie 2.
- Click the **IR Manager** button from the Nixie 2 - **Parameter Panel** at the bottom of the screen.
- At the top of the **BIGSKY MX** panel, click the **New Folder** button to create at least one custom folder into which can import your IR files.
- Within the **MAC MEMORY** or **WINDOWS MEMORY** panel at the left of the IR Manager window, browse to the folder where your reverb IR files are stored on your computer.
- Select the IR file(s) you wish to import and drag and drop into your custom folder within the right **BIGSKY MX** panel.*
- You can also create additional folders and drag individual IRs and folders within the **BIGSKY MX** panel to move and arrange them however you like.

***NOTE:** For import of IR files, BigSky MX will accept mono or stereo .WAV files, 16 or 24 bit, and 48kHz sample rate. Upon import, Nixie 2 will conform IRs to the native format (stereo, 24-bit, 48kHz).

- When you next enter the BigSky MX pedal's **Impulse** parameter menu, you'll have access to your added custom IRs and folders.

NOTE: If you delete a custom IR file from the Nixie 2 **BIGSKY MX** panel that is in use within a saved preset, you'll see **NO IMPULSE** indicated on the pedal's display when loading the preset, and the preset will load with the Impulse reverb inactive. Load a different Impulse or use the Nixie 2 IR Manager to re-import the missing IR file to update the preset.

TIP! To restore all BigSky MX Factory Impulses, you can perform a complete **Factory Reset**—see [page 16](#). This action will **DELETE** all existing IR files from BigSky MX and restore the original Factory IRs. Note that a Factory Reset will restore all factory presets and Global Settings as well.

Cloud Reverb

A gorgeously big, ambient reverb that draws from techniques developed in the late '70s. Using processing power not dreamed of in those days, the Cloud reverb obscures the distinction between reality and fantasy.



The Parameters menu (Cloud reverb type is selected)

Cloud Parameter	Values	Description
Ensemble 		Analyzes the input signal and generates a harmonically rich pad reminiscent of a string section. Increasing the value from minimum to mid values adds a light to medium ensemble for subtle enhancement, and higher values produce a pronounced ensemble effect for creating lush soundscapes.
Diffusion 		Adds diffusors in front of and within the reverb generator. At minimum there is no diffusion effect, and the Cloud reverb is “grainier,” yet mesmerizing, on transient attacks. As Diffusion is increased, the reverb is smoothed and softened.

Using the Cloud Reverb...

The cascaded input diffusion blocks create an expanded “early” reverb. This results in a longer overall reverb time than the displayed tank decay time, most noticeable when the Decay knob is set to low values.

From minimum to 2 o’clock, the Modulation knob adjusts the amount of modulation (developed by a quadrature oscillator at a frequency harmonious to the Cloud generator) that is applied to the input diffusor sections.

Past 2 o’clock, the frequency of the quadrature oscillators is increased. The modulation scheme was developed to allow for high degrees of modulation without muddying up the sustaining reverberation tail.

The Cloud reverb can take any modest guitar or synth sound and turn it into a gorgeous ensemble.



Shimmer Reverb

Two tunable voices add pitch-shifted tones to the reverberated signal, for resplendent, unearthly ambience. The Amount and Feedback parameters allow for a range of shimmer effects from laid-back and subtle to full-blown majestic splendor.



The Parameters menu (Shimmer reverb type is selected)

SHIMMER Parameter	Values	Description		
Shift 1 	(See below)	Selects the first voice interval, from an octave down to two octaves up:		
- Octave	- Tritone	- 10 Cents	+ Perfect 4	+ Major 7
- Major 7	- Perfect 4	+ 10 Cents	+ Tritone	+ Octave
- Minor 7	- Major 3	+ Minor 2	+ Perfect 5	+ Octave + 5th
- Major 6	- Minor 3	+ Major 2	+ Minor 6	+ 2 Octaves
- Minor 6	- Major 2	+ Minor 3	+ Major 6	
- Perfect 5	- Minor 2	+ Major 3	+ Minor 7	
.....				
Shift 2 	(See below)	Selects the second voice interval, from an octave down to two octaves up. Can be set to Off if no second voice is desired:		
Off	- Perfect 5	- Minor 2	+ Major 3	+ Minor 7
- Octave	- Tritone	- 10 Cents	+ Perfect 4	+ Major 7
- Major 7	- Perfect 4	+ 10 Cents	+ Tritone	+ Octave
- Minor 7	- Major 3	+ Minor 2	+ Perfect 5	+ Octave + 5th
- Major 6	- Minor 3	+ Major 2	+ Minor 6	+ 2 Octaves
- Minor 6	- Major 2	+ Minor 3	+ Major 6	
.....				
Amount 		Adjusts the level of the Shift 1 and Shift 2 voices in the reverberated signal from off to maximum.		

SHIMMER Parameter	Values	Description
Feedback 	Input Regen Input+Regen	Allows selection for regeneration of the tank Shimmer effect: <ul style="list-style-type: none"> • Input - Shimmer effect is applied to the input of the reverb core and does not regenerate. • Regen - Shimmer effect is applied within the reverb core and the effect is regenerative, resulting in continuously ascending or descending pitches as the reverb decays. • Input+Regen - Both Input and Regeneration of the Shimmer effect is applied.
Voice 	MX Classic	Offers a choice between two different Shimmer voicings: <ul style="list-style-type: none"> • MX – Sophisticated, clean pitch-shifting with consistent tracking across all intervals, using state-of-the-art frequency domain techniques. • Classic – Lush pitch-shifting using time domain techniques and modulated buffers for a rich, classic sound.

Using the Shimmer Reverb...

The Amount parameter works in conjunction with the Feedback parameter to produce the particular intensity of the shimmer effect. If the Amount is set to minimum, no shimmer effect is heard.

For deep octave-down shifts, increase the Low End parameter to allow the lower octave frequencies to come through strongly.

The Modulation knob modulates the shimmer voices as well as the reverb tank's delay line lengths with a 4-phase oscillator. Increasing the modulation widens the shimmer experience and promotes a general sense of well-being.

Try the Feedback parameter's Input or Regenerative options for different shift behaviors—or choose the Input + Regenerative option for the ultimate shift experience.

Try +0ct and +0ct + 5th with lower Amount parameter levels for just a hint of shimmer.

Try +0ct +5th and -Perfect 5th with Feedback at minimum for an other-worldly synth-pad.

Try -10 Cents and +10 Cents with Feedback and Modulation at minimum for a beautiful, detuned reverb.

Bloom Reverb

In the '90s, more diffusion blocks were added to reverbs to smooth out the sound. A side effect of this was the tendency of the reverbs to have a slowly building envelope that “bloomed,” resulting in big ambient reverbs that sit nicely with the dry signal even at high Mix levels. The Bloom reverb features a bloom generating section that feeds into a traditional reverb tank, with a unique Feedback parameter that expands the possibilities exponentially.



The Parameters menu (Bloom reverb type is selected)

BLOOM Parameter	Values	Description
Length 		Adjusts the length of the “bloom” portion of the reverb. Higher levels will result in longer bloom times.
Feedback 		Adjusts the amount of feedback that is applied around the “bloom” portion of the reverb.
Harmonics 		Analyzes the input signal and generates a harmonically rich pad reminiscent of an analog synth. When set to minimum, no harmonics are added. Increasing to mid values adds a light mix of harmonics for subtle enhancement, and higher values produce more pronounced harmonic enhancement.

Using the Bloom Reverb...

The Decay knob controls the tank's decay time, while the Length parameter controls the bloom duration.

High settings of the Length parameter and/or higher Feedback settings can result in reverbs that are much longer than the displayed tank decay time.

Experiment with short Decay times with higher Length values versus longer Decay times with lower length values to get a feel for how these two aspects of the reverb interact and complement each other.

The Mod knob controls two independent 16-phase oscillators for a total of 32 oscillator signals. The first 16-phase oscillator modulates the bloom-generating delay lines, while the 2nd 16-phase oscillator modulates the tank reverb delay lines. The result is sublime, robust, and beautiful.

The Tone knob is a unique resonant filter that shapes the top end with synth-like voicing. Experiment by adjusting the Tone knob with long-decay reverbs.

High Feedback settings paired with high Modulation results in a gorgeous spectrum of sweeping resonant harmonics.





Turn the Harmonics parameter to a lower value to add some airy overtones, or to higher values for larger synth drones layered onto your decay.

Chorale Reverb

A vocal choir accompanies your music. Choose vowel ranges and intensities to customize the choir as it sings in venues that vary with the Decay knob. As the Modulation is increased, the choir becomes alive with a multitude of voices.



The Parameters menu (Chorale reverb type is selected)

CHORALE Parameter	Values	Description
Vowel 	AAHHOO AAHH AAHHOH OH OOOHOH OOO Random	Selects the vowel sound(s) that the choir will use for accompaniment. The selections include traditional singing formants, AH, OH, OO, and combinations of the two. Also included is the Random choice that will allow any formant to be sung.
Resonance 	Mild Medium High	Adjusts the intensity of the vowel sound by adjusting the vocal filter resonance (Q) values. <ul style="list-style-type: none"> • Mild - Produces subtle vocal qualities. • Medium - Provides increased vocal intensity. • High - Creates the most resonant vowel sounds.
Choir  		Analyzes the input signal and generates a pad reminiscent of a vocal choir. When set to minimum, no choir is added. Increasing to mid values adds a light voice for subtle enhancement, and higher values produce a pronounced choir effect.
Choir Voice 	Tenor Baritone	Selects between two different pitch ranges for the voices: <ul style="list-style-type: none"> • Tenor - For a mid to high chorale range. • Baritone - For a low chorale range.

Using the Chorale Reverb...

Increase the Choir parameter level for more pronounced vocal padding, and use the Choir Voice parameter to choose a lower (Baritone) or higher (Tenor) pitch.

Adjust the Tone knob to add more “breath” and high-end articulation to the vocals.

The Mod knob is very effective to add realism to the chorale. As Mod is turned up, randomization is added to the chorale’s pitch and timbre to create an increasing number of singers that have distinct voices.

Since many of the vocal formant frequencies are “mid-range” frequencies, a mid-heavy guitar amp may overly re-enforce some of them at High Resonance settings. In those cases, reduce the Resonance setting to Medium or Mild.

Magneto Reverb

More than just a reverb, Magneto is also capable of some old-school tape delay, slapback, and patterned repeats. The Magneto reverb sets up a multi-head echo with all heads on, while the Pre-Delay knob adds feedback. The Diffusion parameter adds a new dimension of ambience, smearing the response of the heads and blurring the line between delay and reverb.



The Parameters menu (Magneto reverb type is selected)

MAGNETO Parameter	Values	Description
Diffusion 		Controls the effect of diffusors on the magnetic heads. At minimum there is no diffusion effect. As the Diffusion parameter is turned up, the heads are increasingly smeared, creating a reverberated quality to the repeats.
Heads 	1 2 3 4 6	Selects the number of “tape machine” heads, 1 through 6. Fewer heads offer simpler, distinct repeats, where more heads offer more dense complex patterns, and washes. The Heads settings also affects the Ping Pong LEFT - RIGHT output pattern—see the "Ping Pong" parameter description.
Spacing 	Even Uneven	Affects the distance spacing between the heads. <ul style="list-style-type: none"> • Even Spacing - Puts the heads at the same distance from one another for equal delay times. • Uneven Spacing - Creates more complex, less overtly rhythmic effects.

MAGNETO Parameter	Values	Description
Ping Pong 	Off On	<p>Changes the repeats to alternating between the Left and Right outs for a wide stereo effect.*</p> <ul style="list-style-type: none"> • Off - Disables the Ping Pong effect. • On - Enables the Ping Pong effect. An alternating LEFT - RIGHT - LEFT echo output occurs with Heads set to 1 or 2. With Heads set to 3, 4, or 6, the pattern alternates differently for each head setting (e.g., LEFT - RIGHT - RIGHT and similar). <p>*NOTE: When connected to only the BigSky MX's LEFT OUT, all repeats are automatically centered for a full mono effect.</p>

Knob Functions

For Magneto, the **Decay** and **Pre-Delay** knobs assume different controls than for other reverb types:



DELAY TIME: Sets the Delay time of the last head, up to 1500 milliseconds.



FEEDBACK: Adds feedback from the last head back to the input when Even Spacing is selected. With Uneven Spacing, the feedback is taken from the last two heads.

Using the Magneto Reverb...

The last repeat occurs at the displayed decay time, so with 1 head and even spacing, you'll hear a simple repeat at the Decay knob (Delay Time) value. With multiple heads selected, you'll hear additional repeats, for example, a 300ms Decay time with 3 evenly spaced heads would have repeats at 100ms, 200ms, and 300ms. Switching to a 4-head machine results in delays at 75ms, 150ms, 225ms, and 300ms. Try uneven spacing for more complex repeat patterns.

The age, condition, and alignment of the record and playback heads greatly influence the tonality of magnetic media delays. As a result, they may be bright or dark, high-passed, or fuller in the low frequencies. The Tone knob and Low End parameters are wide-ranging to allow for a full spectrum of tones. As the Feedback (Pre-Delay knob) is increased, the EQ response is regenerative, leading to evolving soundscapes and ambient washes.

Enabling Ping Pong provides dramatic stereo imaging, alternating Magneto's repeats between the Left and Right Outs.

The Mod control acts as a Wow and Flutter generator, adding hypnotic movement and fullness to the sound.



Nonlinear Reverb

A variety of physics-defying reverb shapes are available for special effects and unique textures. Choose from three “backward” shapes (Swoosh, Reverse, and Ramp), employ a Gate, add tremolo (via the Chop parameter) and more. Feedback control (Pre-Delay knob), Decay, and Diffusion parameters allow for a vast array of time-warped possibilities.



The Parameters menu (Nonlinear reverb type is selected)

NONLINEAR Parameter	Values	Description
Shape 	Swoosh Reverse Ramp Gate Gauss Bounce	Offers a choice of shapes that are applied for the nonlinear generator: <ul style="list-style-type: none"> • Swoosh, Reverse, or Ramp - Create “backward” effects with different slope profiles. • Gate - Generates an even amplitude profile with an abrupt cut-off. • Gauss - Creates a “bell curve” profile. • Bounce - Creates an inverted bell shape.
Chop 		Adds amplitude modulation to the reverb decay for interesting tremolo effects. At minimum, no amplitude modulation is added, and moving the slider to the right adds increasingly faster tremolo patterns.
Diffusion 		Controls the effect of diffusors on the nonlinear generator. At minimum there is no diffusion effect and the nonlinear effect is “grainy.” As Diffusion is increased, the effect is smeared and smoothed.
Decay 		Adjusts the decay time of the late reverb. Higher settings produce longer decay times.
Level 		Adjusts the level of the late reverb. Higher settings increase the level of the late reverb. At minimum, the late reverb is turned off.

NONLINEAR Parameter	Values	Description
Mod Speed 		Adjusts the modulation LFO speeds for both the non-linear delay tap lengths and the late reverb's delay lines.

Knob Functions

For Nonlinear, the **Decay** and **Pre-Delay** knobs assume different controls than for other reverb types:



TIME: Sets the time of the nonlinear portion of the reverb.



FEEDBACK: Adds feedback from the nonlinear portion of the reverb back to the input.

Using the Nonlinear Reverb...

The Nonlinear generator feeds into the late reverb. The Pre-Delay knob adds feedback around the nonlinear generator before it enters the late reverb portion, producing repeating nonlinear shapes as you turn the knob clockwise.

The Diffusion parameter softens the Nonlinear portion, and is useful with longer Decay times. High Diffusion levels with short Decay times can result in a “metallic” sound. Reduce the Diffusion parameter in these cases if desired.

Short Decay times and no Feedback (Pre-Delay knob minimum) with the Gate shape provides an interesting, level-independent take on the traditional “gated” reverb.

Try high Feedback levels with some added Modulation to create trippy ambient textures.

Maximum Feedback (Pre-Delay knob maximum) with the Gate shape will produce a nearly endless wash of “multi-tapped” reverb. Try Decay at 800ms and Modulation at 10:00.

Try the Swoosh or Reverse shapes at very short decays (<100ms) for a great slapback effect. Try minimum Diffusion for best results.

The Mod control varies the nonlinear generator tap lengths, as well as the late reverb's delay lines for an expanded experience.

1+2 Parameters

Within the Parameter (**PARAM**) menu are several **1+2 Parameters**, which appear in the **PARAM** menu regardless of which reverb type is in use. The 1+2 parameters are “shared” types and applied simultaneously to *both* **Reverb 1** and **Reverb 2** for the current preset. When **Reverb 2** is Off, the 1+2 parameters are applied to **Reverb 1**. Also, see [“Utilizing Single or Dual Reverbs” on page 8](#).

1+2 parameters appear at the end of the **PARAM** menu list (see [page 19](#)), and are indicated with a **1+2** symbol to their left.





The Parameter menu, showing 1+2 parameters

Settings made for 1+2 parameters are stored individually per preset. The following list includes all 1+2 parameters and their descriptions.

1+2 Parameter	Values	Description
Infinite Latch 	Momentary Latching	Sets the behavior for the INFINITE footswitch as either momentary or latching: <ul style="list-style-type: none"> • Momentary - The Infinite or Freeze is engaged only while the Infinite footswitch is held down. • Latching - The Infinite or Freeze is engaged on push-release of the INFINITE footswitch and disengaged with the next push-release. <p>NOTE: Use any reverb type’s individual Inf Mode parameter to select Infinite or Freeze behavior. See page 21.</p>
Boost 		Changes the output level for the preset, from -3.0dB to +3.0dB. This can be useful for level matching in your effects chain, or can be used as an effect such as for boosting a solo with reverb.

1+2 Parameter	Values	Description
Persist 	On	<p>Allows reverb decay “trails” to continue to be heard when the effect is bypassed:</p> <ul style="list-style-type: none"> • On - Allows reverb “trails” to persist.* • Off - Disables the function so that any audible reverb decay is immediately silenced when the effect is bypassed. <p>*NOTE: Enabling Persist will automatically set BigSky MX to Buffered Bypass—see “Bypass” on page 49.</p> <p>TIP! Enable the Global Spillover option (page 48) to persist trails between preset changes.</p>
	Off	
Expression Pedal Setup 	MIDI On/Off	<p>Allows assignment of one or multiple knobs for expression pedal control per preset. Note that knob assignments can be controlled via an expression pedal connected to the EXP jack and via MIDI control (MIDI CC 100).</p> <ul style="list-style-type: none"> • MIDI On/Off - Enables or disables control of the assigned knobs via MIDI Expression pedal using MIDI CC# 100 for the current preset. (This setting does not affect control via an EXP jack-connected expression pedal.) When the double-arrow indicator appears to the right of MIDI On/Off, turn VALUE to On to enable or Off to disable Expression MIDI control. • Heel and Toe - Connect an expression pedal (TRS, 250k Ohm) to the rear panel EXP jack to assign the desired knob(s) for control and access and configure the Heel and Toe values to set the min. and max. parameter range. <p>See “Expression Pedal Setup” on page 57 for detailed setup instructions</p>
	Heel	
	Toe	

1+2 Parameter	Values	Description
Dual Reverb Enable 	Off Parallel Series 1▶▶2 Series 1◀◀2 Split 1L 2R Split 1R 2L	<p>Configures the preset to utilize one reverb (Off), or any two reverbs with the choice of routing.</p> <ul style="list-style-type: none"> • Off - Disables Reverb 2, so that the preset utilizes only one reverb. • Parallel - Routes the two reverbs in parallel, keeping processing discrete for each. • Series 1▶▶2 - Routes Reverb 1's output into Reverb 2. • Series 1◀◀2 - Routes Reverb 2's output into Reverb 1. • Split 1L 2R - Routes Reverb 1 to the Left Out and Reverb 2 to the Right Out. • Split 1R 2L - Routes Reverb 1 to the Right Out and Reverb 2 to the Left Out. <p>NOTE: All of these options are also available from the TYPE encoder for easy access—see page 8 details.</p>

Copy Settings From 	Presets 00A thru 149B	<p>Allows the selection of another preset to copy its Reverb 1's reverb type and settings instantly to Reverb 2 of the current preset, saving the time of manually configuring your preset. Simply select any preset (00A to 149B) from the list to copy the preset's settings.</p>
---	-----------------------------	---

NOTE: Remember to save the preset after configuring its 1+2 Parameters to retain all edited settings—see [page 15](#).

Global Settings

Global Settings affect BigSky MX regardless of what preset is currently active, allowing the pedal to be customized for your desired setup and workflow. See the following pages for descriptions for all Global Settings.

Accessing the Global Settings

- 1 Push and hold the **VALUE** encoder for 3 seconds to display the **GLOBAL** screen.



- 2 Turn **VALUE** to select the desired Global Setting, then push-release **VALUE** to display its options.

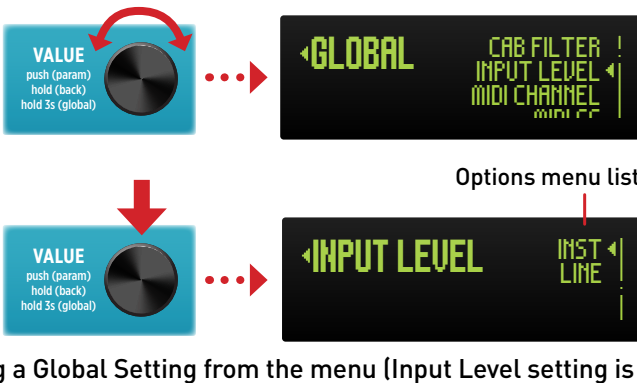

- 3 Turn **VALUE** to choose the desired option (or, if a slider is displayed, turn **VALUE** to adjust it), then push and hold **VALUE** for 1 second to go back to the previous screen.
- 4 Repeat the above steps to configure additional Global Settings as desired.

NOTE: All changes made to Global Settings persist across power cycles.





The Global Settings Options



The following is a list of all Global Settings, including their options and descriptions. Note that factory default settings are indicated within the descriptions.





The Global Settings menu

Global Setting	Values	Description
Bypass 	True Buffered	Sets the bypass mode for BigSky MX: <ul style="list-style-type: none"> • True (default) - The signal passes straight through electromechanical relays—no components are touching the input signal. • Buffered - The bypassed signal runs through the high-quality analog buffer, which can preserve the high-frequency response of your instrument’s signal through your pedal chain and long cable runs. <div style="border: 1px solid #ccc; padding: 10px; margin-top: 10px;"> <p>NOTE: Some features require Buffered Bypass for audio throughput. When BigSky MX is currently set to True Bypass, it will automatically be changed to Buffered Bypass when these options are enabled: "Persist", "Cab Filter", "Spillover", "Dry Signal" - KillDry, and when using stereo output.</p> </div>

Global Setting	Values	Description
Cab Filter 	Off Bright Dark Classic	Sets the Cab Filter Off or allows you to select between several different Speaker Cab emulations: <ul style="list-style-type: none"> • Off (default) - Disables the Cab Filter. • Bright - An IR-based Cab filter designed to be used with a dark sounding guitar or preamp feeding into BigSky MX. • Dark - An IR-based Cab filter designed to be used with a bright sounding guitar or preamp feeding into BigSky MX. • Classic - Derived from a complex analog cab filter circuit, with an amp-like EQ in conjunction and the high frequency roll-off and notching that occurs with a mic'd guitar speaker. <p>NOTE: When any option is selected other than Off: BigSky MX is automatically set to Buffered Bypass—see "Bypass" on page 49. You'll see the Cab Filter icon  appear on the Home Screen to indicate it is enabled.</p>
Input Level 	Instrument Line	Selects the input level sensitivity for the BigSky MX inputs: <ul style="list-style-type: none"> • Instrument Level (default) - For connecting a guitar or bass. • Line Level - For connecting a synth, drum machine, or other output gear or instruments that produce higher output levels.
MIDI Channel 	1-16	Selects the MIDI Channel, 1 (default) through 16, for MIDI communication.
MIDI CC 	Don't Send Send	Disables or enables the transmission of MIDI CC (Continuous Controller) messages generated by the BigSky MX controls: <ul style="list-style-type: none"> • Don't Send - (default) Disables MIDI CC transmission. • Send - Enables MIDI CC transmission.

Global Setting	Values	Description
MIDI Program Change 	Don't Send Send	Disables or enables the transmission of MIDI PC (Program Change) messages generated by the BigSky MX controls: <ul style="list-style-type: none"> • Don't Send (default) - Disables MIDI PC transmission. • Send - Enables MIDI PC transmission.
MIDI THRU 	THRU Merge Off	Sets the MIDI THRU behavior: <ul style="list-style-type: none"> • THRU - MIDI messages that arrive at the MIDI input are sent to the MIDI OUT and USB MIDI without any additional MIDI messages generated by BigSky MX.* • Merge - MIDI messages that arrive at the input and those that are generated by BigSky MX are merged together to be sent to the MIDI OUT.* • Off (default) - Only MIDI messages generated by the controls on BigSky MX are sent to the MIDI output.
<p>*NOTE: For the MIDI THRU - THRU and Merge settings, incoming MIDI data is echoed only on the MIDI port it was received; MIDI received at the 5-pin MIDI IN is echoed only to the 5-pin MIDI OUT, MIDI received at USB MIDI is echoed to the USB MIDI OUT, and MIDI received at the EXP jack's TRS MIDI In (tip conductor) is echoed to the TRS (ring conductor) MIDI Out.</p>		
Footswitch Mode 	Preset Dual	Configures the behavior for BigSky MX footswitches A and B : <ul style="list-style-type: none"> • Preset (default) - Footswitches A and B to load the respective A and B presets for the current preset bank. • Dual - Footswitch A to enable/disable Reverb 1, and footswitch B to independently enable/disable Reverb 2.
<p>NOTE: To configure any preset to utilize single or dual reverbs, see page 8. When set to Dual Footswitch Mode and the current preset is configured for a single reverb, footswitch A toggles the reverb enable/disable and footswitch B has no function.</p>		



Global Setting	Values	Description
Active Banks ACTIVE BANKS	All 0-149	Allows BigSky MX to display and scroll through all 150 preset banks (default), or limits the range of banks that can be selected. Useful if you prefer only to access banks that you might want to use for a particular gig or set.
Home Screen HOME SCREEN	Default Stage Stage Alt	<p>Allows the Home Screen to be configured for different workflows:</p> <ul style="list-style-type: none"> • Default (default) - Shows the most information for the current preset: location number, name, Dual mode, reverb type, and Decay value. • Stage - Shows the preset location number and the name in LARGE text for higher visibility. • Stage Alt - Same as the Stage option but the preset name scrolls initially to fully display long names. <p>Please see page 13 for details.</p>
Preset Navigation PRESET NAV	Direct List	<p>Allows preset selection to be configured in two different ways:</p> <ul style="list-style-type: none"> • Direct (default) - Turning the VALUE encoder immediately loads the next or previous preset. • List - Turning VALUE scrolls through a list of all presets. Pushing VALUE loads the selected preset. <p>Please see page 13 for details.</p>



Global Setting	Values	Description
EXP Mode 	Pedal Bank Preset MIDI	<p>Allows configuration of the BigSky MX's EXP jack to connect the desired type of controller device and its functionality:</p> <ul style="list-style-type: none"> • Pedal (default) - For the use of an Expression Pedal (25K Ohm potentiometer minimum) to control BigSky MX's knobs. • Bank - For the use of a Strymon MultiSwitch or MultiSwitch Plus to access Bank Down, Preset A/B Toggle, and Bank Up. • Preset - For the use of a Strymon MultiSwitch or MultiSwitch Plus to access Preset Down, Bypass, and Preset Up. • MIDI - For the use of TRS MIDI for MIDI CC/PC messages, or for a Strymon MultiSwitch Plus to access Presets 0B, 1A, & 1B. <p>Please see page 55 for setup details.</p>
Dry Signal 	Normal KillDry	<p>Allows the dry signal to be turned on or off. This is useful in a parallel effects loop or mixer send where an effect level may be necessary.</p> <ul style="list-style-type: none"> • Normal (default) - The dry signal is routed to the outputs. • KillDry - Mutes the dry signal, allowing the MIX control to be used as an effect (wet only) level.* <p>*NOTE: When KillDry is selected, BigSky MX is automatically set to Buffered Bypass—see "Bypass" on page 49.</p>

Global Setting	Values	Description
----------------	--------	-------------

Spillover 	On Off	Allows the wet decay signal of the currently selected preset to “spill” into the next selected preset. <ul style="list-style-type: none"> • On - Enables Spillover. • Off (default) - Disables Spillover.
--	-----------	--

IMPORTANT!
 Due to the architecture of the reverb buffer, the current preset must be active for at least 5 seconds before Spillover will be operational.
 Spillover is not functional for the **Impulse** reverb type.
 Enabling Spillover will automatically set BigSky MX to Buffered Bypass—see [“Bypass” on page 49](#).

Display Brightness 		Allows adjustment for the brightness of the display screen from low to high for the best visibility in different environments. (Default is 0.)
---	---	--

LED Brightness 		Allows adjustment for the brightness of the footswitch LEDs from low to high for the best visibility in different environments. (Default is 0.)
---	---	---

Reset all Global Settings

To return all Global Settings to their factory default values, disconnect the power from BigSky MX, then hold the **TYPE** encoder while connecting power until you see the **RESET GLOBALS** message appear on the display. BigSky MX will automatically restart and then be ready for use with all its original factory Global Settings.

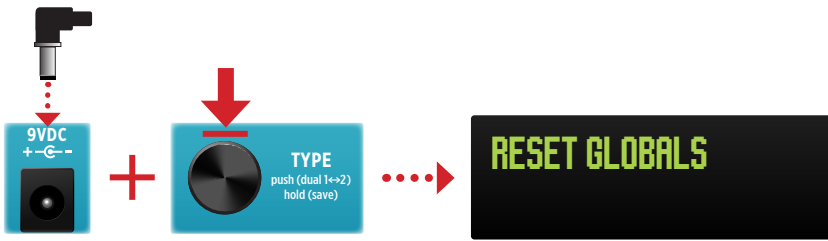

Resetting the Global Settings

Setting Up an Expression Pedal or Strymon MultiSwitch Plus

Configuring the EXP Jack

The BigSky MX rear panel's **EXP** jack can be set to work with an expression pedal, Strymon MultiSwitch/Multiswitch Plus device, or TRS MIDI for different types of external control. The first step is to choose the **Global Settings** menu's **EXP MODE** settings for the device you'll be connecting.

- 1 Push and hold the **VALUE** encoder for 3 seconds to enter the Global Settings (**GLOBAL**) menu (also, see [page 48](#)).



- 2 Turn **VALUE** to select **EXP MODE**, then push-release **VALUE** to display its options.



- 3 Turn **VALUE** to select the desired **EXP MODE** option, then push-release **VALUE** to commit the setting.

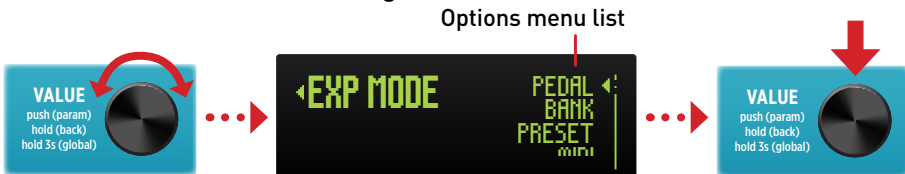

EXP MODE Options

Choose the option that provides the desired control functions for the controller device that you'll be connecting to the **EXP** jack.

- **Pedal** - For use with an external expression pedal (TRS, 25k Ohm potentiometer minimum) for control of BigSky MX's knobs.
- **Bank** - For use with an original Strymon MultiSwitch or a MultiSwitch Plus set to "TimeLine, BigSky, and Mobius mode" (as covered on [page 60](#)). The MultiSwitch device's footswitches perform the following functions:

- **Footswitch A (left footswitch)** - Bank down
- **Footswitch B (middle footswitch)** - Toggles between the A and B presets of the current bank
- **Footswitch C (right footswitch)** - Bank up
- **Preset** - For use with an original Strymon MultiSwitch or a MultiSwitch Plus set to "TimeLine, BigSky, and Mobius mode" (as covered on [page 60](#)). The MultiSwitch device's footswitches perform the following functions:
 - **Footswitch A (left footswitch)** - Preset down
 - **Footswitch B (middle footswitch)** - Bypasses/engages the currently loaded preset
 - **Footswitch C (right footswitch)** - Preset up
- **MIDI** - For use with an external MIDI controller (TRS MIDI) for preset access and parameter control or preset changes. Alternatively, for use with a Strymon MultiSwitch Plus set to "Preset mode" (as covered on [page 60](#)) to recall three specific presets. The MultiSwitch Plus device's footswitches perform the following functions:
 - **Footswitch A (left footswitch)** - Loads preset 0B
 - **Footswitch B (middle footswitch)** - Loads preset 1A
 - **Footswitch C (right footswitch)** - Loads preset 1B

NOTE: The EXP MODE jack setting persists across power cycles and is not saved per preset.

Please proceed to the following configuration section for details on how to complete the setup for your specific controller:

- ["Expression Pedal Setup" on page 57.](#)
- ["Configuring BigSky MX for MultiSwitch or MultiSwitch Plus" on page 59.](#)
- ["Connecting a TRS MIDI Controller Device:" on page 66.](#)

Expression Pedal Setup

Use a TRS expression pedal for continuous control of any desired BigSky MX knob(s). These control settings can be created and stored individually for each preset.

- 1 Configure the **Global Settings - EXP MODE** jack setting for **Pedal** mode (the factory default setting).



Selecting the Global Settings - EXP MODE - Expression option

- 2 Connect an expression pedal to the BigSky MX **EXP** jack using a TRS cable.



Connecting a TRS expression pedal

NOTE: Your expression pedal must include a 25k Ohm potentiometer minimum to work correctly with BigSky MX.

- 3 On the Home screen, push and release the **VALUE** encoder to enter the **PARAM** menu. Turn **VALUE** to select the **1+2 EXP Setup** option and push-release **VALUE** to enter the setup options screen.



Entering the Expression Setup options screen

- 4 Within the **EXP Setup** screen, the **MIDI EXP ON/OFF** setting is initially selected and set to **ON** by default, as indicated by the double arrows (see the preceding image). No change is necessary for this **ON** setting.*

***NOTE:** This **ON/OFF** setting only affects MIDI control of the MIDI Expression pedal function using MIDI CC# 100. Optionally, you can turn **VALUE** to set **MIDI EXP** to **OFF** to disable the preset's Expression settings from being controlled via MIDI CC 100. Also, see [page 62](#).

- 5 While the **EXP Setup** screen is displayed, rock the connected expression pedal fully to its minimum “heel” position. Double-arrows appear to the right of the **HEEL** parameter, indicating it is ready to learn the knob and value to be assigned.

Turn the knob you wish to control, such as **DECAY** in our example, and set the knob value you wish to be used as the pedal’s **HEEL** (minimum) value. We’ll set this as “0,” as shown below.



Move Exp pedal to HEEL position

Turn DECAY knob to set its HEEL value

NOTE: The **EXP Setup** is a “shared” 1+2 type parameter. Therefore, once you assign a knob to the pedal, the pedal will control this knob for both reverbs if your current preset includes Dual reverbs. Also, see [“1+2 Parameters” on page 45](#).

TIP! Optionally, assign additional knobs for expression control. Just adjust any additional knob(s) to the desired minimum **HEEL** value at this step.

- 6 Rock the expression pedal fully to its maximum “toe” position. The double-arrows now appear to the right of the **TOE** parameter. Turn the **DECAY** knob to set your preferred **TOE** (maximum) value—we’ll choose a Decay of “200.”



Setting the TOE value

NOTE: If any additional knobs were assigned in the previous step, adjust them to the desired maximum **TOE** position before proceeding.

- 7 Once the above settings are made, your pedal assignment is configured. Push and hold the **VALUE** encoder for 1 second to back out of the **EXP Setup** and **PARAM** screens and start using the pedal with the configured preset.

NOTE: Save the preset to retain your expression pedal settings. Pedal assignment settings are stored individually per preset—see [“Saving Presets” on page 15](#).

TIP! When MIDI Expression is enabled and the **EXP** jack is set to **MIDI Mode** you can send MIDI CC 100 with values 0 (heel) to 127 (toe) to perform the expression pedal assignment setup, and control your pedal assignments via MIDI.

Configuring BigSky MX for MultiSwitch or MultiSwitch Plus

Configure BigSky MX to be used with a Strymon MultiSwitch or MultiSwitch Plus device (sold separately) for external control. Configuration differs slightly for a MultiSwitch versus a MultiSwitch Plus—please refer to the section below for your device.

NOTE: Please also refer to the respective Strymon Products pages for additional details regarding [Multiswitch](#) and [MultiSwitch Plus](#).

Configuring BigSky MX for a MultiSwitch Device

- 1 Press and hold the **VALUE** encoder for 3 seconds to enter the Global Settings (**GLOBAL**) menu.



- 2 Turn **VALUE** to **EXP MODE**, press **VALUE**, and then select either **Bank** or **Preset**, depending upon your preferred functionality, as shown in the table below. Also, see ["EXP Mode Options" on page 55](#) for details.

EXP MODE	Left FS Function	Middle FS Function	Right FS Function
BANK	Bank Down	Preset A/B	Bank Up
PRESET	Preset Down	Bypass/Enable	Preset Up

MultiSwitch EXP MODE control functions

- 3 Connect one end of a 1/4 inch, TRS-to-TRS cable to the BigSky MX **EXP** jack.

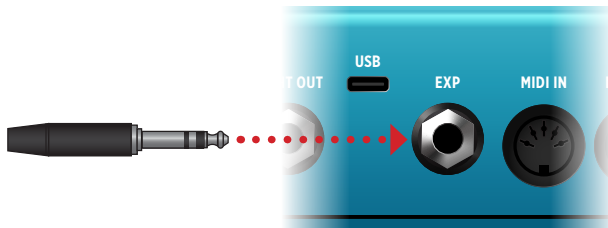

- 4 Connect the other end of the TRS cable to any of the three MultiSwitch inputs.

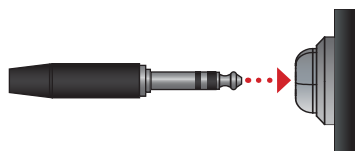

- 5 The connected MultiSwitch should now perform the selected Bank or Preset BigSky MX control functions.

Configuring BigSky MX for a MultiSwitch Plus Device

- 1 Press and hold the **VALUE** encoder for 3 seconds to enter the Global Settings (**GLOBAL**) menu, then turn **VALUE** to select and configure the following individual settings (also, see [page 48](#)).



- Set **MIDI CHANNEL** to **Channel 1** (factory default).

NOTE: If you wish transmit MIDI CCs (when adjusting knobs) and PC messages (when changing presets) from the BigSky MX **MIDI OUT** to control other MIDI devices, set the **MIDI CC** and **MIDI PC** options to **Send**. If you wish to route incoming MIDI "through" to other MIDI devices, set **MIDI THRU** to **THRU** or **Merge**. Please see ["Using MIDI" on page 62](#).

- Set **EXP MODE** to either the **Preset**, **Bank**, or **MIDI** option, depending upon your preferred functionality, as shown in the table below. Also, see ["EXP Mode Options" on page 55](#) for details.

EXP MODE	FS A Function	FS B Function	FS C Function
BANK	Bank Down	Preset A/B	Bank Up
PRESET	Preset Down	Bypass/Enable	Preset Up
MIDI	Loads preset 0B	Loads preset 1A	Loads preset 1B

MultiSwitch Plus EXP MODE control functions

- 2 Connect one end of a 1/4 inch, TRS-to-TRS cable to the BigSky MX **EXP** jack.

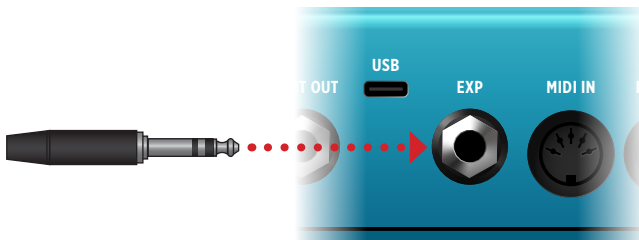

- 3 Note that the next step for connecting the other end of the TRS cable to MultiSwitch Plus differs, depending on the Global Settings - **EXP MODE** you selected in the preceding Step 1:

To connect MultiSwitch Plus for the Bank or Preset EXP MODE

Press and hold the MultiSwitch Plus device's **B** and **C** footswitches simultaneously while connecting the TRS cable to any of the three MultiSwitch Plus inputs—hold the footswitches until you see the MultiSwitch Plus **B** and **C** LEDs flash **RED**. (This MultiSwitch Plus configuration is referred to as "TimeLine, BigSky, and Mobius mode.")

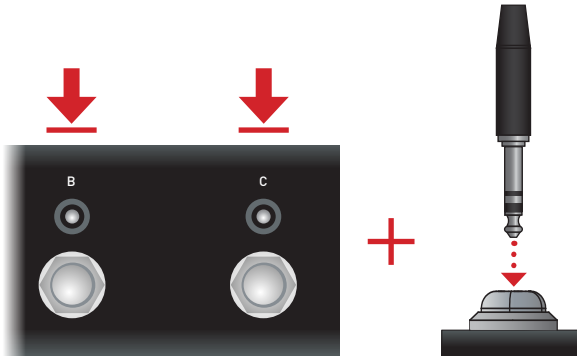

Release the switches and you'll see all three MultiSwitch Plus LEDs flash **GREEN** to confirm the connection.

To connect MultiSwitch Plus for the MIDI EXP MODE

Press and hold the MultiSwitch Plus **A** (left) footswitch while connecting the TRS cable to any of the three MultiSwitch Plus inputs—hold the footswitch until you see MultiSwitch device's **A** (left) footswitch LED flash **RED**. (This MultiSwitch Plus configuration is referred to as "Preset mode.")

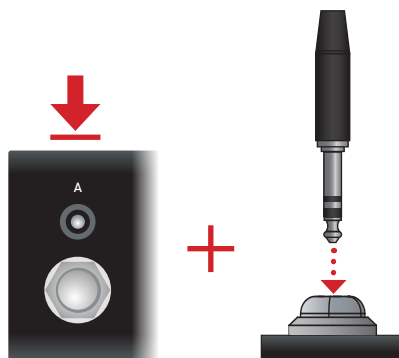

Release the switches and you'll see all three MultiSwitch Plus LEDs flash **GREEN** to confirm the connection.

- 4 The connected MultiSwitch Plus should now perform the selected Bank, Preset, or MIDI BigSky MX control functions.

NOTE: The BigSky MX's **EXP MODE** jack setting persists across power cycles and is not saved per preset.

Using MIDI

BigSky MX can respond to MIDI via **MIDI IN** (5-pin), USB, and the **EXP** jack (TRS MIDI). MIDI Continuous Controller (CC, or sometimes referred to as "Control Change") messages are used for control of its knobs and parameters, and MIDI Program Changes (PC) sent to BigSky MX are used to recall presets, as listed in the reference tables later in this chapter.

Additionally, BigSky MX can be configured to send MIDI commands via its 5-pin MIDI OUT, USB, and EXP jack (TRS) MIDI outputs when adjusting its knobs and changing presets. Incoming MIDI messages can also be configured to be routed "THRU," allowing you to pass MIDI control messages to other gear.

TIP! Please also check the [Strymon Support FAQs](#), [Blog](#), and [Tech Corner](#) articles for more about MIDI configurations for all Strymon pedals.

Connecting an External MIDI Controller

The following steps describe connecting and configuring BigSky MX with a MIDI controller. It is recommended to check the manufacturer's website to make sure your MIDI controller device is current with any available updates. Also consult the device's documentation for its own necessary settings.

To Connect a 5-pin MIDI Controller Device:

- 1 Using standard 5-pin MIDI cables, connect the **MIDI OUT** port of your MIDI controller to the **MIDI IN** port of BigSky MX.

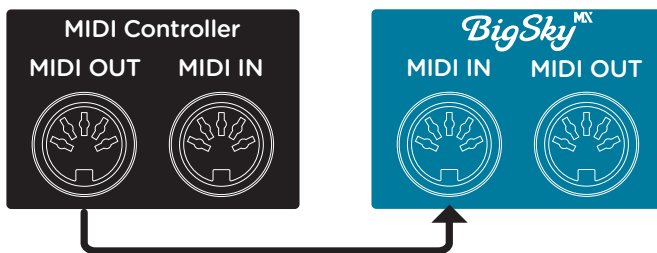

Connecting a single BigSky MX pedal with an external MIDI controller device

- 2 Push and hold the BigSky MX **VALUE** encoder for 3 seconds to access the **GLOBAL** menu and configure the following Global Settings.

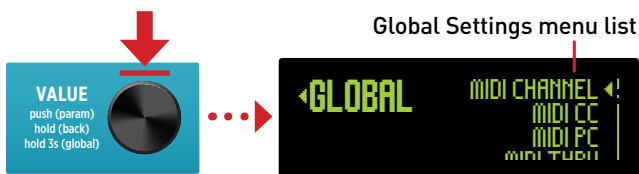

- Set **MIDI CHANNEL** to Channel 1 (or any channel can be used, as long as this channel is matched on your controller device).
- 3 Configure your hardware controller to transmit the desired MIDI PC and/or MIDI CC commands to control the desired BigSky MX Bank/Preset and parameter changes. Please see [page 68](#) and [page 70](#) for the complete reference lists of MIDI PC and CC commands for BigSky MX.
 - 4 Your BigSky MX is now configured and ready for MIDI control.

TIP! A simple way to check that communication is working is to send CC #102 with a value of 127 when the current preset's footswitch is bypassed. This will enable the footswitch (and its LED will light) if MIDI is properly connected and configured.

Connecting a 5-pin MIDI Controller with Multiple Pedals:

Optionally, you can connect BigSky MX along with one or multiple additional pedals using a MIDI “chain” configuration for simultaneous control.

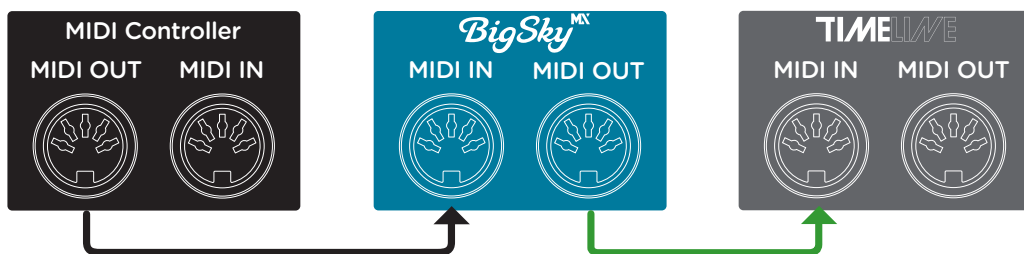

Connecting two pedals in a chain configuration with a MIDI controller

- 1 Start by connecting the **MIDI OUT** of your MIDI controller to the **MIDI IN** port of the first pedal in the chain. Note that it typically does not matter the order of your pedals in the chain—MIDI commands can pass to all of them (depending on each pedal's own MIDI settings). In our example, BigSky MX is first in the chain following a controller device.
- 2 Connect a loose MIDI cable from the **MIDI OUT** port of the of the first pedal to the **MIDI IN** port of the second pedal.
- 3 If you are connecting more pedals, follow this same “chain” cabling pattern, from **MIDI OUT** to the next pedal's. There is no need to connect the **MIDI OUT** of the last pedal in the chain back to the MIDI controller.
- 4 Push and hold the BigSky MX **VALUE** encoder for 3 seconds to access its **GLOBAL** menu and configure the following Global Settings (also, see [page 48](#)):
 - Set **MIDI CHANNEL** to 1 (or any channel can be used, as long as this channel is matched on your controller's Send channel).

- Set **MIDI CC** to **Don't Send** (the default setting) so that BigSky MX does not transmit CCs when you adjust its knobs and parameters.
- Set **MIDI PC** to **Don't Send** (the default setting) so that BigSky MX does not transmit PCs when you change its presets.
- Set **MIDI THRU** to **THRU** or **MERGE** if you want all incoming MIDI data to be routed out the 5-pin MIDI OUT.*

***NOTE:** You can optionally configure any pedal in the chain to a unique MIDI Channel number if you wish to have it respond to different commands than your other pedal(s) in the chain. In this scenario, you would program your controller to send the desired unique MIDI commands to be transmitted on each pedal's respective MIDI Channel.

- 5 When connecting a Strymon pedal, such TimeLine or Mobius, as an additional MIDI pedal in the chain, configure its Global Settings as desired (please see the respective Strymon pedal's [User Manual](#) for its MIDI settings). If using another manufacturer's pedal, you'll likely need to configure its own MIDI settings as well—see the manufacturer's documentation.
- 6 Your BigSky MX is now configured and ready for MIDI control. Please see [page 68](#) and [page 70](#) for the complete reference lists of MIDI PC and CC commands for BigSky MX.

TIP! A simple way to check that communication is working is to send CC #102 with a value of 127 when the current preset's footswitch is bypassed. This will enable the footswitch (and its LED will light) if MIDI is properly connected and configured.

Utilizing BigSky MX as a 5-pin MIDI Controller to Sync Presets of Other Pedals

It is also possible to use BigSky MX as a controller device, to Send MIDI PC messages to your other pedals, such as Strymon TimeLine and Mobius pedals, to synchronously change their presets.

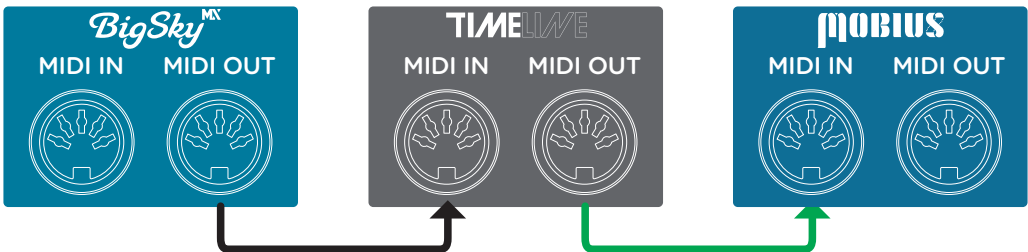

Connecting BigSky MX to TimeLine and Mobius for preset control

- 1 Start by connecting the **MIDI OUT** of your BigSky MX to the **MIDI IN** port of the next pedal in the chain, such as TimeLine. Note that it typically does not matter the order of your pedals following BigSky MX in the chain—MIDI commands can pass to all of them.
- 2 Connect a loose MIDI cable from the **MIDI OUT** port of the of the first pedal after BigSky MX (TimeLine) to the **MIDI IN** port of the subsequent pedal, which will be Mobius in our example. There is no need to connect the **MIDI OUT** of the last pedal in the chain back to BigSky MX.
- 3 Push and hold the BigSky MX **VALUE** encoder for 3 seconds to access its **GLOBAL** menu and configure the following Global Settings (also, see [page 48](#)):
 - Set **MIDI CHANNEL** to 1 (or any channel can be used, as long as the same MIDI channel is selected on your TimeLine and Mobius).
 - Set **MIDI CC** to **Don't Send** (the default setting) so that BigSky does not transmit CC messages when you adjust its knobs or parameters.
 - Set **MIDI PC** to **Send** to transmit MIDI Program Changes to its **MIDI OUT** when changing presets. This will be received by the TimeLine and Mobius pedals and change their preset locations, 000 to 299, synchronously.
 - Set **MIDI THRU** to **Merge** to allow BigSky MX to transmit MIDI PC messages from its own preset changes.
- 4 BigSky MX is now configured for preset control of your MIDI-connected pedals. Please also see ["MIDI Program Changes Reference" on page 68](#) for more info.

Connecting a TRS MIDI Controller Device:

The BigSky MX **EXP** jack can be configured for 1/4-inch TRS MIDI communication. Some MIDI controller devices and interfaces, such as [Strymon Conduit](#), offer 1/4-inch TRS type MIDI connections. Strymon also offers [5-pin to TRS MIDI](#) cables that work with some MIDI interfaces to connect to the BigSky MX **EXP** jack.

- 1 Connect your MIDI controller or interface to the BigSky MX **EXP** jack.

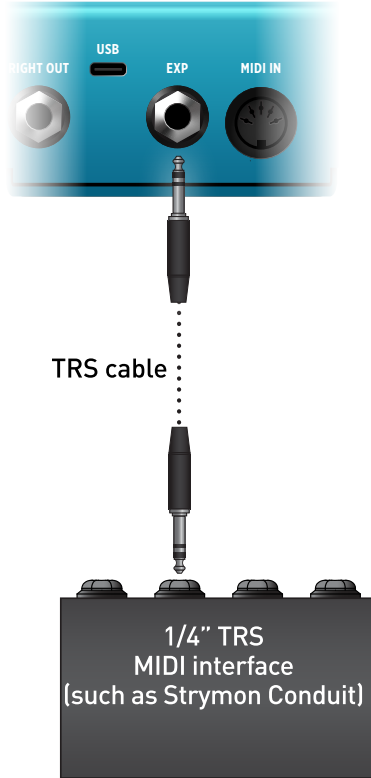

- 2 Press and hold the **VALUE** encoder for 3 seconds to enter the **GLOBAL** menu and configure the following individual Global Settings (also, see [page 48](#)).



- Set **MIDI CHANNEL** to 1 (the factory default setting) You'll also want to set your MIDI controller to transmit on the same channel.
- Set **MIDI CC** and **MIDI PC** to **Don't Send** (the default settings), so that these messages are not sent to the TRS MIDI Output.
- Set **MIDI THRU** to **Off** (the default setting), so that MIDI data is not routed to the TRS MIDI Output.

- Set **EXP MODE** to **MIDI**.

NOTE: For Strymon pedals' TRS MIDI connection, the MIDI data is received from the TIP conductor of the TRS jack. If **MIDI CC** or **PC Send** or **MIDI THRU** is enabled on these pedals, MIDI data is sent out of the pedal from the RING conductor of the jack.

- 3 Press and hold the **TYPE** encoder for 3 seconds to exit the **GLOBAL** menu and return to the Home screen.
- 4 BigSky MX is now configured and ready for TRS MIDI communication. Please see [page 68](#) and [page 70](#) for the complete reference lists of MIDI PC and CC commands for BigSky MX.

TIP! A simple way to check that communication is working is to send CC #102 with a value of 127 when the current preset's footswitch is bypassed. This will enable the footswitch (and its LED will light) if MIDI is properly connected and configured.

MIDI Program Changes Reference

BigSky MX contains 150 banks with A and B preset locations within in each bank, for a total of 300 preset locations. Banks are numbered 00 to 149 on the display. Because MIDI Program Change (MIDI PC) messages have a maximum number of 128 (0-127), the presets are grouped into three **MIDI Patch Banks**. The preset locations are numbered sequentially, using Program Change numbers 0-127, within each of the MIDI Patch Banks:

- MIDI BANK 0** = PRESETS 000A - 063B
Accessed via MIDI CC 0, Value 0 (for Bank 0)*
followed by MIDI PC 0-127
- MIDI BANK 1** = PRESETS 064A - 127B
Accessed via MIDI CC 0, Value 1 (for Bank 1)
followed by MIDI PC 0-127
- MIDI BANK 2** = PRESETS 128A - 149B
Accessed via MIDI CC 0, Value 2 (for Bank 2)
followed by MIDI PC 0-43

NOTE: Some MIDI applications and controllers start with MIDI Program Change 1 instead of 0. In these setups, increment the MIDI Program Change locations above by one.

To access MIDI Banks 0, 1, or 2 it is advisable to send a standard MIDI Bank Change message (MIDI CC# 0 with a value equal to the MIDI Bank#) preceding the MIDI Program Change message, as shown in the above table.*

***TIP!** The BigSky MX pedal always powers up in MIDI Patch Bank 0, so if you plan to stay within the first 127 presets, send just a standard MIDI Program Change (0 - 127) message to load preset 000A through 063B.

Saving Presets via MIDI

Once you have a MIDI Controller configured for communicating with BigSky MX (see ["Connecting an External MIDI Controller" on page 62](#)), the currently-loaded settings can be saved to any BigSky MX preset locations via MIDI. This requires sending PC messages from your controller to BigSky MX while it is displaying the Preset Save screen, as follows:

- 1 Dial in the sound you would like to save as your preset on BigSky MX.
- 2 Push and hold the BigSky MX **TYPE** encoder button down for 2 seconds to enter the **Save** screen—use the **TYPE** and **VALUE** encoders to enter a name for your preset (also, see ["Saving Presets" on page 15](#)).
- 3 While the **Save** screen is displayed, send a MIDI Program Change (PC) message from your MIDI controller for the desired preset location (000 - 299) to save the preset to this location. This can be as simple as just pressing a preset switch on your MIDI controller. Once this MIDI PC message is sent to store the preset, this MIDI controller switch will recall the same preset.

MIDI CC Reference

The following are the lists of pre-configured MIDI Continuous Controllers (MIDI CCs) for BigSky MX parameters.

Knobs and Common Parameters - All Reverb Types

Parameter	Reverb 1 CC	Reverb 2 CC	Values
Reverb Type Encoder	1	2	0-11
Decay Knob	3	4	0-127
Pre-Delay Knob	5	6	0-127
Output Level	7	8	0-16
Pan	9	10	0-16 0 = Full Left 8 = Center 16 = Full Right
Tone Knob	11	12	0-127
Mod Knob	13	14	0-127
Mix Knob	15	16	0-127
Infinite Mode	17	18	0-2: 0 = Freeze 1 = Infinite 2 = Off
Param 1 Knob	19	20	0-127
Param 2 Knob	21	22	0-127
Low End	23	24	0-20

1+2 Parameters - Shared

Parameter	CC	Values
Infinite Latch	98	0 = Momentary 1 - 127 = Latching
Boost	79	0-60: 0 = -3dB 30 = 0dB 60 = +3dB)
Persist	84	0 = Off 1-127= On
Dual Mode	99	0-5: 0 = Off 1= Parallel 2 = Series 1 >> 2 3 = Series 1 << 2 4 = Split L R 5 = Split R L

Reverb-Specific Parameters

Parameter	Reverb 1 CC	Reverb 2 CC	Values
Room - Size	25	26	0-1: 0 = Studio 1 = Club
Room - Diffusion	27	28	0-20
Room - Voice	29	30	0-1: 0 = MX 1 = Classic
Hall - Mid	35	36	0-20
Hall - Size	37	38	0-1: 0 = Concert 1 = Arena
Hall - Swell Rise	39	40	0-22
Hall - Swell Type	41	42	0-1: 0 = Wet 1 = Dry
Hall - Voice	43	44	0-1: 0 = MX 1 = Classic
Chamber - Color	45	46	0-4 0 = Neutral 1 = Clear 2 = Smooth 3 = Crisp 4 = Deep
Plate - Size	47	48	0-1: 0 = Small 1 = Large
Plate - Voice	49	50	0-1: 0 = MX 1 = Classic
Spring - Dwell	51	52	0-3 0 = Clean 1 = Combo 2 = Tube 3 = Overdrive

Parameter	Reverb 1 CC	Reverb 2 CC	Values
Spring - Number	53	54	0-2 0 = One Spring 1 = Two Springs 2 = Three Springs
Spring - Voice	55	56	0-1: 0 = MX 1 = Classic
Impulse - Attack	57	58	0-16
Impulse - Stretch	59	60	0-16
Impulse - Tail	61	62	0-1: 0 = Envelope 1 = Gate
Impulse - Direction	63	64	0-1: 0 = Forward 1 = Reverse
Impulse - Feedback	65	66	0-15
Cloud - Diffusion	67	68	0-20
Cloud - Ensemble	69	70	0-15
Shimmer - Shift 1	71	72	0-27:
0 = - Octave	7 = - Perfect 4	14 = + Minor 2	21 = + Minor 6
1 = - Major 7	8 = Major 3	15 = + Major 2	22 = + Major 6
2 = - Minor 7	9 = - Minor 3	16 = + Minor 3	23 = + Minor 7
3 = - Major 6	10 = - Major 2	17 = + Major 3	24 = + Major 7
4 = - Minor 6	11 = - Minor 2	18 = + Perfect 4	25 = + Octave
5 = - Perfect 5	12 = - 10 Cents	19 = + Tritone	26 = + Octave + 5th
6 = - Tritone	13 = + 10 Cents	20 = + Perfect 5	27 = + 2 Octaves
Shimmer - Shift 2	72	73	0-28:
0 = - Off	8 = - Perfect 4	16 = + Major 2	24 = + Minor 7
1 = - Octave	9 = Major 3	17 = + Minor 3	25 = + Major 7
2 = - Major 7	10 = - Minor 3	18 = + Major 3	26 = + Octave
3 = - Minor 7	11 = - Major 2	19 = + Perfect 4	27 = + Octave + 5th
4 = - Major 6	12 = - Minor 2	20 = + Tritone	28 = + 2 Octaves
5 = - Minor 6	13 = - 10 Cents	21 = + Perfect 5	
6 = - Perfect 5	14 = + 10 Cents	22 = + Minor 6	
7 = - Tritone	15 = + Minor 2	23 = + Major 6	
Shimmer - Amount	75	76	0-18

Parameter	Reverb 1 CC	Reverb 2 CC	Values
Shimmer - Feedback	77	78	0-2 0 = Input 1 = Regeneration 2 = Input + Regeneration
Shimmer - Voice	85	86	0-1: 0 = MX 1 = Classic
Bloom - Length	87	88	0-17
Bloom - Feedback	89	90	0-17
Bloom - Harmonics	91	92	0-15
Chorale - Vowel	93	94	0-6 0 = AAHHOO 1 = AAHH 2 = AAHHOH 3 = OH 4 = OOOHOH 5 = OOO 6 = Random
Chorale - Resonance	95	96	0-2 0 = Mild 1 = Medium 2 = High
Chorale - Choir	103	104	0-15
Chorale - Choir Voice	105	106	0-1 0 = Tenor 1 = Baritone
Magneto - Diffusion	107	108	0-20
Magneto - Heads	109	110	0-4 0 = One 1 = Two 2 = Three 3 = Four 4 = Six

Parameter	Reverb 1 CC	Reverb 2 CC	Values
Magneto - Spacing	111	112	0-1 0 = Even 1 = Uneven
Magneto - Ping Pong	113	114	0-1 0 = Off 1 = On
Nonlinear - Shape	115	116	0-5 0 = Swoosh 1 = Reverse 2 = Ramp 3 = Gate 4 = Gauss 5 = Bounce
Nonlinear - Chop	117	118	0-17
Nonlinear - Diffusion	119	120	0-20
Nonlinear - Decay	121	122	0-17
Nonlinear - Level	123	124	0-18
Nonlinear - Mod Speed	125	126	0-17

Hardware Control and Other

Parameter	CC	Values	Notes
A Footswitch	80	0 = Press 127 = Release	
B Footswitch	81	0 = Press 127 = Release	Send CC using a momentary type switch controller.
Infinite Footswitch	82	0 = Press 127 = Release	
Value Encoder	83	0 = Scroll counter-clockwise 1 = Scroll clockwise	
Infinite Off/On	97	0 = Off 1-127 = On	
Expression Pedal	100	0-127	CC 100 will control the per-preset knob assignments you create using the PARAM menu's - EXP Setup screen. The EXP Setup - MIDI EXP option must also be set to ON to allow MIDI control—see page 57 .
Bypass	102	0 = Bypassed 1-127 = Engaged	
MIDI Patch Bank	0	0-2: <ul style="list-style-type: none"> 0 = Bank 0 (Preset locations 00A - 63B) 1 = Bank 1 (Preset locations 064A - 127B) 2 = Bank 2 (Preset locations 128A - 149B) 	Send CC 0 with the value of 0, 1, or 2 to select the respective Bank 0, 1, or 2, followed by MIDI PC to select a Preset location within the Bank—see page 68 .

NOTE: Many MIDI controllers send out values 0 and 127 for on/off switches.

NOTE: Some MIDI applications and controllers start their MIDI enumeration with 1 instead of 0. In these setups, increment the numbers above by one.

Factory Default Global Settings

The following are the Global Settings factory default values for your reference.

Global Setting		Factory Default Value
Bypass Mode:	True Bypass	
Input Level:	Instrument	
MIDI Channel:	1	
MIDI CC:	Don't Send	
MIDI PC:	Don't Send	
MIDI THRU:	Off	
Footswitch Mode:	Preset	
Active Banks:	All	
Home Screen:	Default screen	
Preset Navigation:	Direct	
Expression Mode:	Pedal	
Dry Signal:	Normal	
Spillover:	Off	
Display Brightness:	0	
Footswitch LED Brightness:	0	

If desired, you can reset all Global Settings to their factory default values—see [page 54](#).

Specifications

Feature	Specification Value
Input Impedance:	1 Meg Ohm
Output Impedance:	100 Ohm
A/D & D/A:	24-bit, 96 kHz
Max Input Level:	+10 dBu
Signal/Noise:	116 dB typical
Bypass Switching:	True Bypass (electromechanical relay switching)
Dimensions:	5" deep x 6.875" wide x 2.375" tall

Power Source Requirements

Use a power source with the following rating: 9VDC, center negative, 500mA minimum (sold separately).

TIP! We recommend the [Strymon Zuma and Ojai](#) advanced power supply units for BigSky MX, as well as for all Strymon pedals.

Strymon Non-Transferable Limited Warranty

Warranty

Strymon warrants the product to be free from defects in material and workmanship for a period of two (2) years from the original date of purchase when bought new from an authorized dealer in the United States of America or Canada. If the product fails within the warranty period, Strymon will repair or, at our discretion, replace the product at no cost to the original purchaser. Please contact your dealer for information on warranty and service outside of the USA and Canada.

Exclusions

This warranty covers defects in manufacturing discovered while using this product as recommended by Strymon. This warranty does not cover loss or theft, nor does the coverage extend to damage caused by misuse, abuse, unauthorized modification, improper storage, lightning, or natural disasters.

Limits of Liability

In the case of malfunction, the purchaser's sole recourse shall be repair or replacement, as described in the preceding paragraphs. Strymon will not be held liable to any party for damages that result from the failure of this product. Damages excluded include, but are not limited to, the following: lost profits, lost savings, damage to other equipment, and incidental or consequential damages arising from the use, or inability to use this product. In no event will Strymon be liable for more than the amount of the purchase price, not to exceed the current retail price of the product. Strymon disclaims any other warranties, expressed or implied. By using the product, the user accepts all terms herein.

How to Obtain Service Under this Warranty

For North American customers: Contact Strymon through our website at strymon.net/support for Return Authorization and information. Proof of original ownership may be required in the form of a purchase receipt.

For International Customers: Contact the Strymon dealer from which the product was purchased from in order to arrange warranty repair service.

Strymon[®] is a division of Damage Control Engineering[®], LLC.

Safety and Compliance Information

This equipment has been tested and found to comply with the limits for a class B digital device, pursuant to part 15 of the FCC Rules. These limits are designed to provide reasonable protection against harmful interference in a residential installation. This equipment generates, uses, and can radiate radio frequency energy and if not installed and used in accordance with the instructions, may cause harmful interference to radio communications. However, there is no guarantee that interference will not occur in a particular installation. If this equipment does cause harmful interference to radio or television reception, which can be determined by turning the equipment off and on, the user is encouraged to try to correct the interference by one or more of the following measures:

- 1) Reorient or relocate the receiving antenna.
- 2) Increase the separation between the equipment and receiver.
- 3) Connect the equipment into an outlet on a circuit different from that to which the receiver is connected.
- 4) Consult the dealer or an experienced radio/TV technician for help.



Legal Notices

Strymon BigSky MX User Manual contents © 2024 Damage Control Engineering, LLC. All Rights Reserved.

No part of this publication may be reproduced in any form without the express written permission of Damage Control Engineering, LLC.

Strymon, the Strymon logo, and Damage Control Engineering are trademarks or registered trademarks of Damage Control Engineering, LLC. in the U.S. and/or other jurisdictions. Mac and macOS are trademarks of Apple, Inc., registered in the U.S. and other countries and regions. Windows is a registered trademark of Microsoft Corporation in the United States and/or other countries.

Original Strymon BigSky MX Impulse Response audio recordings © 2024 Damage Control Engineering, LLC. All Rights Reserved.

The following Original Strymon BigSky MX Impulse Response audio recordings (IRs), along with any accompanying materials, are protected by copyright law and are the intellectual property of Damage Control Engineering, LLC. All rights are reserved. Any unauthorized reproduction or distribution of these IRs, in whole or in part, is strictly prohibited and may result in legal action. This includes but is not limited to copying, sharing, or selling the IRs without prior written permission from Damage Control Engineering, LLC. For licensing inquiries or permission requests, please contact:

Strymon / Damage Control Engineering
2488 Townsgate Rd., Ste A
Westlake Village, CA 91361 USA
Phone: (805) 468-8788
Email: info@strymon.net

Original Strymon BigSky MX IRs

140 LONG	HAMM SPRING	480 HALL
140 MED	RECEIVER SPR	960 TAJ
250 LONG	PREMIER SPR	960 OIL CAN
VINTANK SPR	SPACE SPRING	RMX REVERSE

Creative Commons Licenced Impulse Response Audio Recordings

The following Impulse Response audio recordings (IRs) are licensed under Creative Commons attributions, as listed.

BigSky MX IR Name	Original IR Name	Source URL	CC License Type & URL	Author(s)
WAREHOUSE	Terry's Factory Warehouse	https://www.openair.hosted.york.ac.uk/?page_id=735	CC BY 4.0	Dr. Damian T. Murphy
REACTOR HALL	R1 Nuclear Reactor Hall	https://www.openair.hosted.york.ac.uk/?page_id=626	CC BY 4.0	Dr. Damian T. Murphy
MAES HOWE	Maes Howe	https://www.openair.hosted.york.ac.uk/?page_id=602	CC BY 4.0	Dr. Damian T. Murphy
MAUSOLEUM	Hamilton Mausoleum	https://www.openair.hosted.york.ac.uk/?page_id=502	CC BY 4.0	Dr. Damian T. Murphy
YORK MINSTER	York Minster	https://www.openair.hosted.york.ac.uk/?page_id=797	CC BY 4.0	Dr. Damian T. Murphy
CORAL CAVE	Capricorn IR #1	https://freesound.org/people/franeknflute/sounds/395210/	CC0 1.0	franknflute (freesound.org user)
K10 SPRING	Fisher K10 Stereo	https://freesound.org/people/derickgtwk/sounds/528139/	CC0 1.0	derickgtwk (freesound.org user)
ST GEORGES	St. George's Episcopal Church	https://www.openair.hosted.york.ac.uk/?page_id=688	CC BY 4.0	Adam Townsell
CHAPEL	Lady Chapel, St. Albans Cathedral	https://www.openair.hosted.york.ac.uk/?page_id=595	CC BY 4.0	Marcin Gorzel, Gavin Kearney, Aglaia Foteinou, Sorrel Hoare, Simon Shelley
ELVEDEN HALL	Elveden Hall (Suffolk England)	https://www.openair.hosted.york.ac.uk/?page_id=459	CC BY 4.0	Matt Rogalsky