

# MB Instrument Pre P

## OWNER'S MANUAL

### TECH SPECS

- **INPUT:** Impedance 1,1 Mohm
- **EQ CONTROLS**
  - LOW Level:  $\pm 15$  dB; Center Freq. (Freq. 85Hz)
  - MID Level:  $\pm 15$  dB; Center Freq. (Freq. 500Hz)
  - HIGH Level:  $\pm 15$  dB; Center Freq. (Freq. 8500Hz)
- **POWER SUPPLY**
  - VOLTAGE: 9V or 18V (2x9V)
  - Power consumption: 700  $\mu$ A (with 9V supply)
  - Battery life: 500 hours with a capacity of 350 mA/h
- **DIMENSIONS**
  - WIDTH: 47mm
  - DEPTH: 32mm
  - HEIGHT: 10mm
- **WEIGHT:** 35g

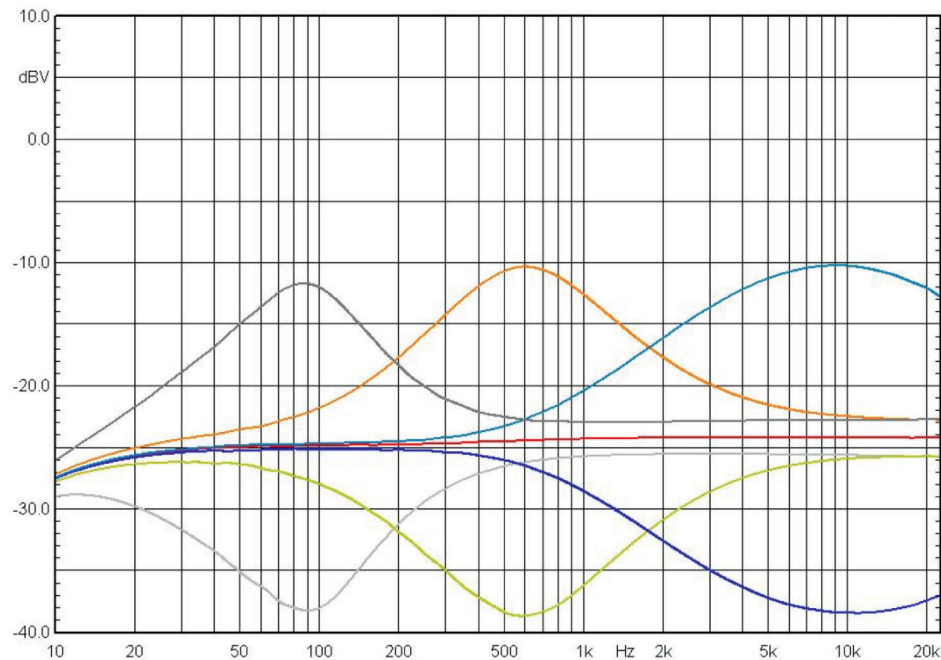

# **MB Instrument Pre P**

## OWNER'S MANUAL

After many requests from players worldwide, Markbass is now proud to offer its amazing onboard preamp for your bass. It will allow you to cover any of your EQ and tone shaping needs and tailor your sound to perfection.

The MB INSTRUMENT PRE has been created after several tests and built with the best components on the market.

We concentrated all our know-how into this ultra-compact circuit and chose the right frequencies for the best sound reproduction.

Its tone control circuits were designed not only to enhance these frequencies but to give an amazing unique and rich response when you boost as well as you cut them whilst always offering a very clean and focused bass tone with extreme settings without losing tone details in the whole frequency range.

Furthermore, the circuits were developed to offer fairly subtle differences of volume when you switch from passive to active and vice-versa: a very well appreciated feature by all musicians.

It offers a wide range of wiring/application options and it works either at 9V or 18V, with a very low power consumption for an exceptionally long battery life.



# MB Instrument Pre P

## Vol/Vol/Tone (act/pass) / 3 band Eq

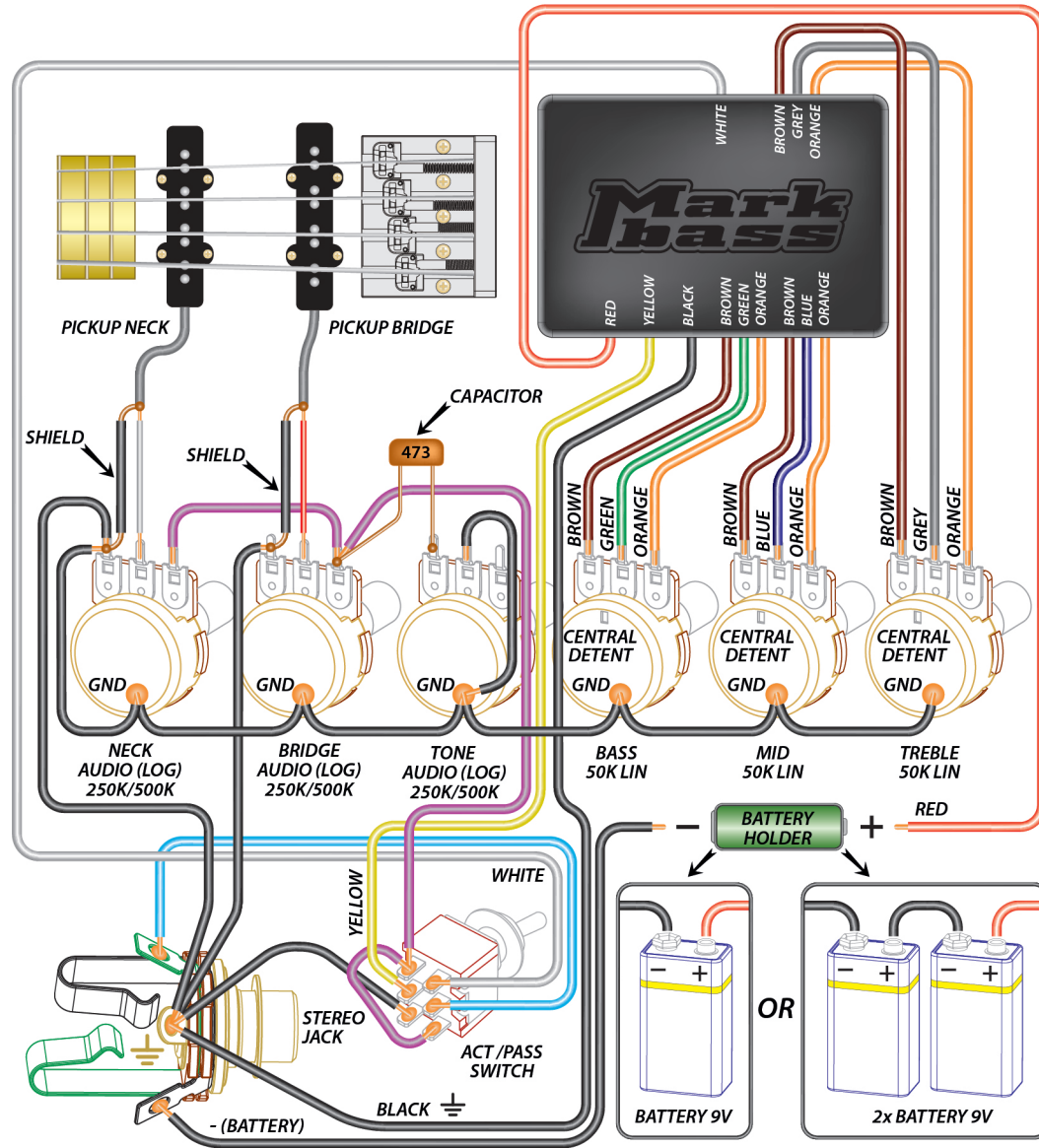

[www.markbass.it](http://www.markbass.it) - [info@markbass.it](mailto:info@markbass.it)