

ALURA

Vision 180 Spot 180 W LED Spot Moving Head

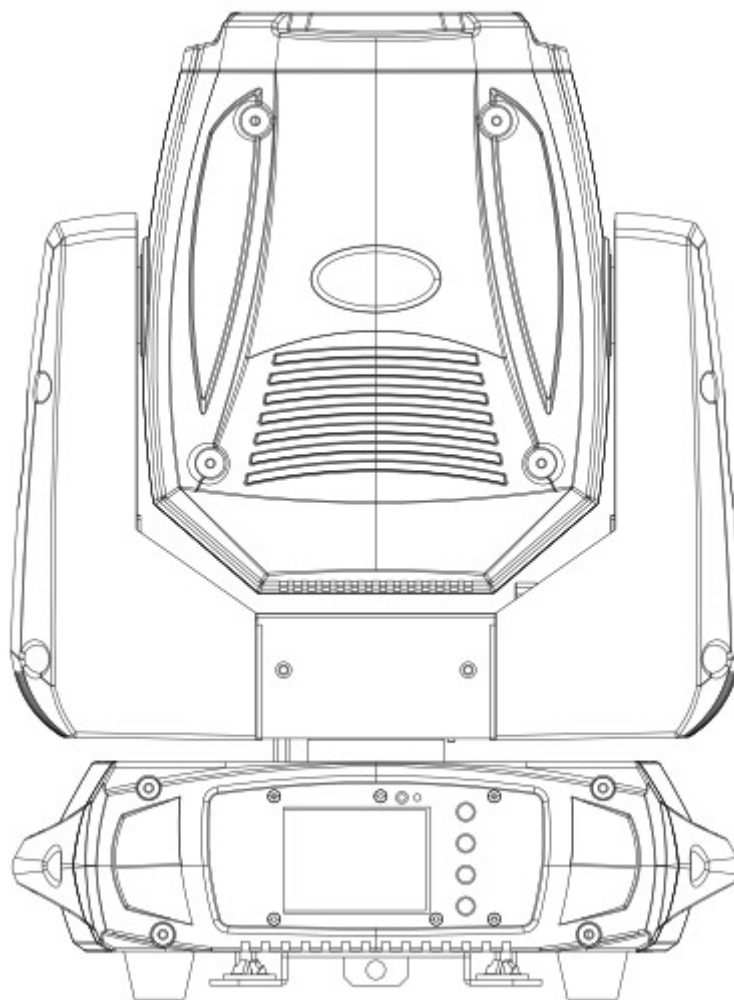

User Manual

The information included in this user manual is subject to change at any time and without notification:

Version: 1.1 Date & Author Initials: 09-02-2022 RV

Revision Date & Author Initials: -

Introduction

Thanks for purchasing the Ayra Vision 180 Spot. This compact moving head offers a versatile array of features so you can get the best results at any event. This user manual contains all the information you need to know before using the unit.

Before unpacking the box, we recommend reading this user manual thoroughly to ensure that you are familiar with all of the features and functions the Vision 180 Spot has to offer. When unpacking the box, please make sure that all of the components and accessories listed below have been included. If the device does not function as it should, unplug any connected cables before contacting your local retailer for further advice.

Box contents:

- Vision 180 Spot LED moving head
- quick-lock mounting bracket
- Locking blue power plug to CEE 7/7 hybrid plug power cable
- Basic DMX connecting cable for testing
- Safety-cable with carabiner hook

Inspection of the Device & Included Accessories

If the device or any of the included accessories have been damaged or rendered defective in transit, please contact your local retailer for further advice.

Please note: The products seen in the images included in this manual may differ slightly from the actual products.

AYRA

The information included in this user manual is subject to change at any time and without notification:

Version: 1.1 Date & Author Initials: 09-02-2022 RV

Revision Date & Author Initials: -



WARNING!



Keep this device away from moisture, water and rain to prevent any danger of electric shocks!



WARNING!



This device must only be connected to a power socket that matches the specified mains voltage. If this device is connected to a power socket with a different voltage, it may cause permanent damage or lead to harmful effects including fire hazards or electric shocks.



WARNING!



Always take care when operating this device. Avoid touching any external or internal wiring when live as they may cause harmful electric shocks!

Safety Instructions

Every person involved with the installation, operation and maintenance of this device must:

- Be qualified.
- Be skilled.
- Have read the instructions included in this user manual.
- Be sure that neither the device nor the included accessories are damaged. Should the device or the included accessories be damaged, please contact your retailer for further advice.
- Ensure that the device is in good working condition and is safe to operate. Please follow the advice and instructions as they are described in this user manual.

Damage caused by misuse and/or modifications made to the device are not covered by the warranty.

This device does not contain any parts that can be repaired or replaced by the user. Should maintenance or repairs be necessary, they must be carried out by a qualified technician.

The light source of the device cannot be replaced. In the event that the light source fails, the entire device will need to be replaced.

Important Health & Safety Information:

- Do not remove any labels or stickers from this device.
- Do not leave any cables lying around where they are in danger of causing a tripping hazard.
- The housing of this device must not be opened and any hardware or software that may be present must not be modified.
- For optimal performance, any inputs should not be fed with a signal higher than necessary.
- The device must only be used indoors; contact with water, rain and moisture must always be avoided. Do not place any objects containing liquid on top of the device.
- Never expose the device to flames or heat sources; do not place it near flammable fluids, gases or objects.
- Disconnect this device from a power source if it is not being used for a long period of time, if maintenance is required, or if it needs to be cleaned.
- Do not pull or tug on any cables to remove plugs as this may cause damage.
- Do not use any cables other than those specified in this manual. Do not use defective cables. Please contact your retailer if the included or specified cables do not function properly with this device.

The information included in this user manual is subject to change at any time and without notification:

Version: 1.1 Date & Author Initials: 09-02-2022 RV

Revision Date & Author Initials: -

- Only ever power this device via a stable AC mains power socket.
- Only power this device using a grounded power socket.
- In the event that the device is exposed to extreme temperature changes (e.g. transported from a cold outdoor environment into a warm indoor environment), it must not be turned on until it has reached room temperature. This is necessary to prevent moisture (condensation) from forming inside the device, which may cause electric shocks.

Use & Operation Guidelines:

- This device is intended for professional use on stages, in venues, theatres or clubs and similar entertainment locations.
- This device is not suitable for use by children and must always be operated by an adult.
- - This device is a light effect designed for entertainment spaces. It is not designed to serve as normal home lighting.
- This device can only be used in appropriate environments where no damage to the device can occur. Do not use the device in moist or dusty environments such as:
 - indoor swimming pools where chlorine is used
 - beaches or any location where sand and/or salt is present
 - outdoors
- in indoor spaces where intense heat sources are present, or where it can reach temperature levels that would be considered uncomfortable for a human being.
- Avoid impact and collisions during use and transport. Do not move or transport the device while it is in use. Avoid using excessive force when installing and operating the device.
- Any user must become familiar with the functions of this device before using it.
- If the device is not operated in the manner described in this user manual, damages or even injuries could occur. Ayra will not be held responsible for any injuries or damages that occur as a result of improper use of this product.

Storage & Transport:

- This device is designed for mobile use and can be transported in its original packaging or in a flight case with a foam-lined interior as long as it is well protected against shocks and impact.
- This device has not been designed for continuous (24/7) use. Regularly switching the device off will not affect the expected lifespan of the device. Always switch off and unplug the device when it is not in use.
- When the device is not in use for long periods of time, always disconnect the device from the mains power and store it in a dust free environment.
- Do not expose the device to extreme temperature shifts.

Housing:





- Frequently inspect the housing of the device and always just before use. Avoid operating the device if any large dents or cracks are found in the housing, or if screws are missing. Do not use the device if the housing is not in good condition. Contact your local retailer or a qualified technician if you are unsure about the state of the device.
- Check the device and screws for any corrosion. If any corrosion is found, do not use the device. Contact your retailer or a qualified technician if the screws or housing show any signs of corrosion.
- Ensure that every power and signal socket is securely fitted. Do not use the device if any of the sockets are not secure.
- Avoid the build up of any dust and dirt. Clean the device once a month by disconnecting it from the power supply and wiping it down with a dry or slightly moist cloth. If the device is used frequently, the device should also be cleaned more frequently.

The information included in this user manual is subject to change at any time and without notification:

Version: 1.1 Date & Author Initials: 09-02-2022 RV

Revision Date & Author Initials: -

Symbol Explanation:

	WEEE: Ensure that this device is disposed of properly. This product falls under the WEEE (Waste Electrical and Electronic Equipment) directive. The requirements of this directive apply to all manufacturers and producers of electronic devices in the EU. Do not throw this product away with normal refuse. Please contact your local authority for more information about how to recycle and dispose of these products in your region. By recycling this product in the proper manner, we can work together to ensure that we can continue to enjoy these kinds of products and still protect the environment as much as possible.
	CE: The CE logo indicates that this product meets the European norms and requirements to which it must legally conform.
	UKCA: The UKCA mark indicates that this product conforms to the directives and standards that this product is legally required to comply with in the United Kingdom.
	For indoor use only: This product was designed for indoor use only. The maximum environmental temperature must not exceed 40 degrees Celsius (104 degrees Fahrenheit).
	Minimum Distance: Maintain a minimum distance of 0.15m between the lens and any objects to prevent overheating and the danger of fire hazard.

ALURA

Contact:
Ayra Professional Lighting Products
Verrijn Stuartweg 18
4462 GE Goes
The Netherlands

*This is a correspondence address only. Please do not send any physical products to this address.
If you need to send a product for repairs or for a refund, please contact your retailer for an RMA request
(Return Merchandise Authorisation)*

The information included in this user manual is subject to change at any time and without notification:

Version: 1.1 Date & Author Initials: 09-02-2022 RV

Revision Date & Author Initials: -

Overview

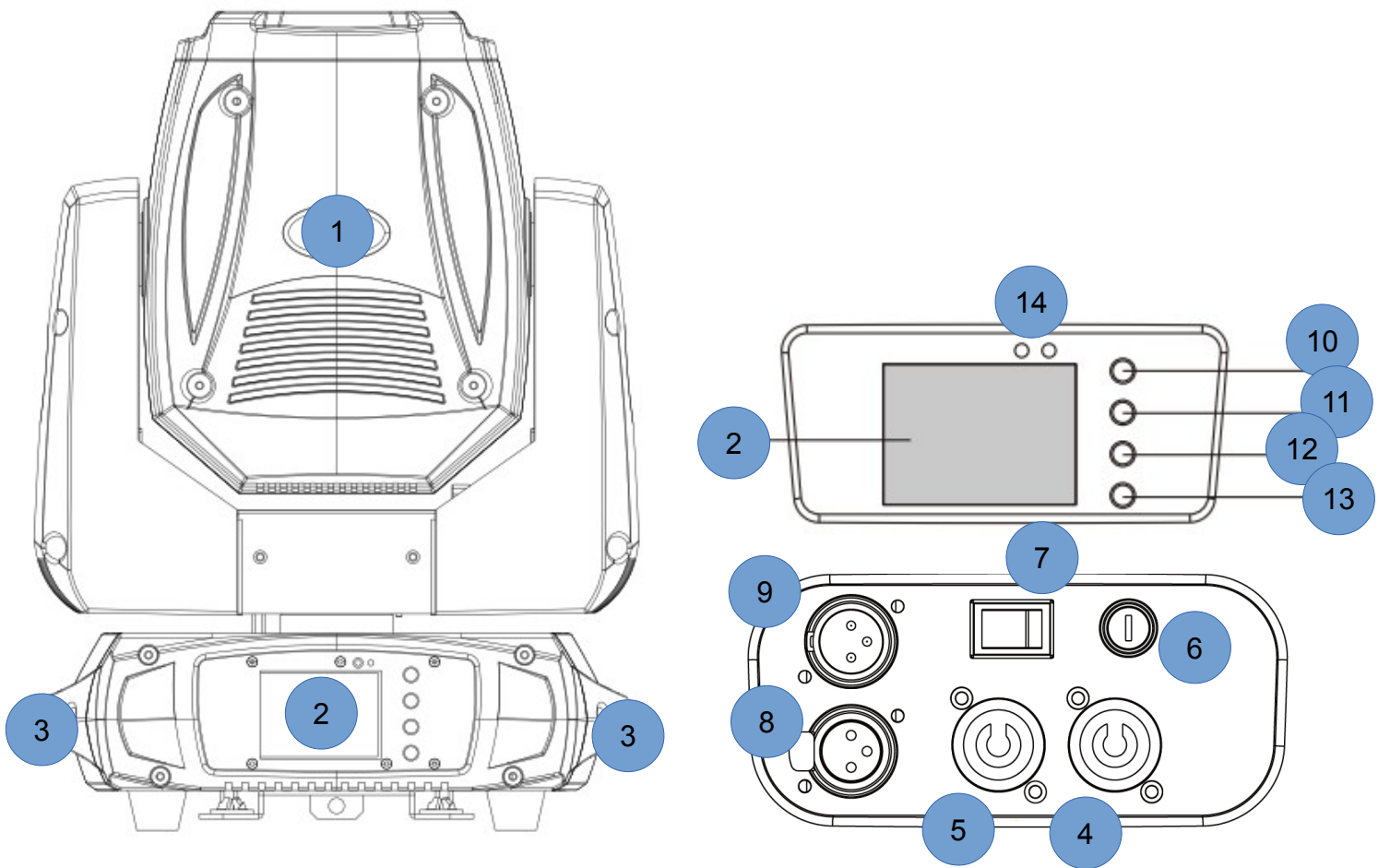

1. Moving head with light output via lens
2. Display with menu buttons
3. Handle
4. Power output (link output) via white locking power socket
5. Power input via blue locking power socket
6. Fuse compartment for internal fuse
7. On/Off switch
8. 3-pin F-XLR for DMX output/link to chained fixture
9. 3-pin M-XLR for DMX input from DMX controller
10. Menu button: MENU
11. Menu button: UP
12. Menu button: DOWN
13. Menu button: ENTER
14. LED indicators

Base:

- Quick-lock suspension bracket mounting point (for suspended installation)
- Mounting eyelet for securing safety cable (for suspended installation)

A full explanation of these functions is included later in this manual, including illustrations.

The information included in this user manual is subject to change at any time and without notification:

Version: 1.1 Date & Author Initials: 09-02-2022 RV

Revision Date & Author Initials: -

Set Up & Operation

To test the device after unpacking it, make sure it is placed on a flat and stable surface far away from any other objects that may hinder the moving head of the device.

Activate the device by plugging it into a nearby power socket and flipping the power switch into the On position. The device will now power up.

During the start-up process, the device cannot be controlled. Once the start-up process is complete, the device will jump to the last-used mode. Now the operating mode and other settings can be changed via the menu display and buttons.

During the start-up process, all of the motors (for movement and for applying effects to the light beam) are calibrated. This brings all motors back to zero - so to a starting position. During this process, the device may appear to stutter, but this is common with a unit of this type. The start-up process should not last longer than approximately 30 seconds, depending on the position of the head and how far it needs to move to return to the zero-point position.

When a DMX signal is detected, the device shall automatically jump to DMX mode and the last-used DMX address will be displayed. If the device is being used for the first time, the DMX address 001 will be displayed. The DMX address can be changed via the menu display and buttons.

Via the menu display and buttons, the functions and settings of the device can be changed. Using the 'Enter' button, you can select a function or confirm any changes. Using the 'Up' and 'Down' buttons, the values of various functions can be changed, and using the 'Menu' button, you can return to the main menu.

The menu includes the following options and functions:

Main Menu	Sub Menu	Function	Settings & Values
	DMX Address	Setting the DMX address. The DMX channel value dictates the DMX command channel	A001 - AXXX
	Channel mode	DMX-channel mode	CH14 (14-channels) CH16 (16-channels)
Function mode	Auto Run / Sound Control	<p>Auto Run Plays back one of the built-in shows at a speed set by the user. Select master or slave mode. Ensure smooth performance by setting the speed and movement separately.</p> <p>Sound Control Plays back one of the built-in shows in time to any music or sound detected by the built-in microphone. Here the tempo of the detected sound determines the playback speed.</p>	Show 1 – 9 State: Master / Alone Auto Run (on/off) Music Run (on/off) Step Time: 1 – 10* Scan Speed: 1 – 10* Auto Focus (on/off) Focus Set (A/B/C/D/E)
Option	Reset Default	Restore factory settings.	Yes / No
	Signal set	DMX signal input method.	Wire (wired, default) Wireless DMX input (DMX via wireless receiver) ACT WDMX & OUT (DMX via wireless receiver and wired output)
	Pan / Tilt	<p>Please note: At the time of writing, this unit only supports a standard wired DMX connection via a cable. It is possible that future updates and extensions will expand functionality.</p> Pan/tilt inversion and pan and tilt range limit settings. Pan controls left and right movements. Tilt controls up and down movements.	Reverse Pan (On / <u>Off</u>) Reverse Tilt (On / <u>Off</u>) Select Pan (630 / <u>540</u> / 360)

The information included in this user manual is subject to change at any time and without notification:

Version: 1.1 Date & Author Initials: 09-02-2022 RV

Revision Date & Author Initials: -

System Information	UI SET	User Interface settings, including: Microphone sensitivity	Select Tilt (270 / 180 / 90) Limit mode: <u>Off</u> / Centre / Right / Left)
		DMX signal mode. When enabled, the device will switch to Blackout mode in the event of DMX signal-loss.	Mic Sensitivity (0 – 99%)
	Temperature	When enabled, Split Colours can be used	OFF signal mode (ON / OFF)
		Current operating temperature of unit	Half Colour Wheel (ON / OFF)
Reset	Software Version	Current software version of device	Temperature displayed in degrees Celsius (not adjustable)
	Total Reset – completely reset unit Pan / Tilt reset – Reset pan / tilt Colour reset – Reset colour wheel Gobo reset – Reset gobo-wheel(s) Others reset – Reset other motors/effect wheels	Current software version of device	Current software version (not adjustable)
Manual Control	Channel	Manual control over all set channels. Here, all functions can be set manually, without the need for any external control equipment.	Total Reset Pan / Tilt reset Colour reset Gobo reset Others Reset
		When manual mode is active, the current settings remain active as long as the user does not return to the main menu.	Pan Pan Fine Tilt Tilt Fine Move Speed Colour Wheel Gobo 1 wheel Gobo rotation Gobo 2 wheel
		When this mode is activated, the current setting values are applied. The values can be adjusted and saved, but as soon as the user returns to the main menu, the values will expire.	Strobe Dimmer Focus Prism Color time Gobo time
Advanced	Channel Calibration	Built-in effect wheel calibration options	
		<p>Please note: The motors are factory calibrated. Adjusting the calibration can lead to slight visual differences when multiple units are chained and synchronised.</p> <p>During normal operation, it is not possible to calibrate the motors of this unit. Recalibration will not solve any issues, but will only return the motor to the starting position.</p> <p>To make calibration adjustments, the following access code is required: 088.</p>	Pan Tilt Colour Wheel Gobo 1 Wheel Gobo rotation Gobo 2 Wheel Focus Prism

Bonus: Display Flip function

This hidden function is commonly used when the unit is suspended. By holding down the UP and DOWN

The information included in this user manual is subject to change at any time and without notification:

Version: 1.1 Date & Author Initials: 09-02-2022 RV

Revision Date & Author Initials: -

buttons for three seconds, the display will be vertically mirrored (flipped upside down), making it easier to read when the unit is in a suspended position.

Explanation of Auto Focus Function

When this moving head is used in a space where the distance between the ceiling/floor and the left/right walls is not the same, then certain colours and gobos will not be sharply projected. This is because of the focus setting of the light beam, which is normally set via DMX. However, most DMX controllers and desks are not designed to continuously adjust the focus of a moving head to ensure a consistently sharp projection, simply because adjustments would have to be made constantly, as the fixture moves from one position to the next,

To compensate for this, and to ensure as sharp a projection as possible at all times, Auto Focus mode can be used. This mode allows the user to set the focus values to a number of fixed points.

An average focus value is then continuously calculated for all intermediate positions. In practice, the moving head automatically corrects the focus value according to the position of the head.

5 positions are used to set the Auto Focus. These 5 positions are based on the projection direction of the moving head and are as follows:

- Straight Up
- Left
- Right
- Forwards
- Backwards

These 5 points serve as base points that draw a virtual 'hemisphere' around the moving head. This is because the moving head is able to move freely across a maximum 630 degree horizontal and a maximum 270 degree vertical, so it could be in any position between each point.

The Auto Focus system also has its limitations. For example, a standard 'box-shaped' installation space is assumed. So the system has been designed for projecting light into a space with a cube or cuboid shape.

The focus range of this moving head is also mechanically limited. As such, it is not possible to achieve an extremely sharp projection at a distance of approximately one metre, simply because the optics have not been designed for this.

Of course, it is possible to override the Auto Focus function and, for example, set the desired focus value via DMX to achieve the sharpest possible light projection in the space where you're working.

Operating Modes

The various operation modes, accessed via the menu functions listed above, are explained in full below:

Auto:

In automatic mode, you can select an operating mode that is not dependent on any external equipment or factors (e.g. a DMX controller, chained master unit, or detected sound). Select one of the basic programmes, then you will be able to set parameters like the speed.

Sound:

Sound-controlled, or sound mode, sets the unit to respond to any sound or music detected by the integrated microphone. In this mode, the unit will perform an automatic light show and move in near-perfect synchronisation to any detected music.

When no music or sound is detected (for example: if only higher frequencies are detected during the break of song), then the unit will continue to move very slowly so that the light show does not come to a complete standstill. As soon as music is registered by the microphone, then the unit will continue the programme in time to the detected beat.

Slave

In Slave mode, it's possible to chain multiple units of the same type so that their functions can be synchronised. This means that multiple units can perform a tight and coordinated light show in time with one another. In principle, an unlimited number of slave units can be connected to a master unit, but a DMX booster will be required. In general, no issues should occur when four units are chained in a master-plus-three-slave chain to complete a four unit setup.

Please note: When units designed by a different manufacturer are chained together, even if the functionality seems identical, strange behaviour can occur. This is usually because specific functions are linked to the incorrect channel. This applies to all DMX lighting fixtures of all brands and types.

DMX

DMX mode is the most extensive control method, since it grants direct control over every function this unit has to offer. In DMX mode, a limited number to a large number of functions can be controlled via a DMX controller or DMX software.

This unit can be set to various different channel modes so that the channel layout, as listed below, matches the layout of your DMX circuit and with the functions that you actually need.

This unit can be used in 14-channel or 16-channel DMX mode. Because the channel layout is 100% identical for the first 14 channels, the overview included below covers the 16-channel version of the layout. For ease channels 15 and 16 have been highlighted in grey.

CH	Function	Value
1	Pan – Pan movement	000 – 255
2	Pan fine – Pan Fine movement	000 - 255
3	Tilt – Tilt movement	000 - 255
4	Tilt fine – Tilt Fine movement	000 - 255
5	Colour wheel	000 – 007: Open white 008 – 015: Open white 016 – 023: Colour 1 024 – 031: Colour 1 + Colour 2 032 – 039: Colour 2 040 – 047: Colour 2 + Colour 3
	Please note: This list covers the options when the Split Colour function is enabled.	
	If this function is disabled, split colours cannot be	

The information included in this user manual is subject to change at any time and without notification:

Version: 1.1 Date & Author Initials: 09-02-2022 RV

Revision Date & Author Initials: -

	used and the previous main colour will still be displayed approximately to those values before the values of a new main colour is reached.	048 – 055: Colour 3 056 – 063: Colour 3 + Colour 4 064 – 071: Colour 4 072 – 079: Colour 4 + Colour 5 080 – 087: Colour 5 088 – 095: Colour 5 + Colour 6 096 – 103: Colour 6 104 – 111: Colour 6 + Colour 7 112 – 119: Colour 7 120 – 127: Colour 7 + Open white 128 – 189: Forwards Rainbow effect, fast - slow 190 – 193: Rainbow effect stop 194 – 255: Backwards Rainbow effect, slow - fast
6	Gobo wheel 1 (with rotating gobos)	000 – 009: Open (no gobo) 010 – 019: Gobo 1 020 – 029: Gobo 2 030 – 039: Gobo 3 040 – 049: Gobo 4 050 – 059: Gobo 5 060 – 069: Gobo 6 070 – 089: Gobo 1 shake slow - fast 090 – 109: Gobo 2 shake slow - fast 110 – 129: Gobo 3 shake slow - fast 130 – 149: Gobo 4 shake slow - fast 150 – 169: Gobo 5 shake slow - fast 170 – 189: Gobo 6 shake slow - fast
7	Gobo wheel 1 gobo rotation	190 – 255: Gobo scroll effect slow - fast 000 – 003: No function 004 – 127: Forward gobo-rotation, fast – slow 128 -131: Gobo rotation stop 132 – 255: Backwad gobo-rotation, slow - fast
8	Gobo wheel 2 (with fixed gobos)	000 – 014: Open (no gobo) 015 – 029: Gobo 1 030 – 044: Gobo 2 045 – 059: Gobo 3 060 – 074: Gobo 4 075 – 089: Gobo 5 090 – 104: Gobo 6 105 – 119: Gobo 7 120 – 134: Gobo 8 135 – 144: Gobo 1 shake slow - fast
9	Shutter	000 – 031: Shutter shut 032 – 063: Shutter open 064 – 095: Strobe effect, slow – fast 096 – 127: Shutter open 128 – 159: Pulse effect, slow – fast 160 – 191: Shutter open 192 – 223: Random strobe effect, slow – fast 224 – 255: Shutter open
10	Dimmer	000 – 255: Dimmer 0 – 100%
11	Focus	000 – 255: Focus close – far
12	Rotating prism	000 – 005: No prism 006 – 127: Prism on

The information included in this user manual is subject to change at any time and without notification:

Version: 1.1 Date & Author Initials: 09-02-2022 RV

Revision Date & Author Initials: -

13	Pan / Tilt speed (movement speed)	128 – 189: Prism rotation forward, fast - slow 190 – 193: Prism rotation stop 194 – 255: Prism rotation backward, fast - slow 000 – 225: max. to min. speed 226 – 235: Blackout when unit moving 236 – 245: Blackout when effect wheel moving (colours/gobos/prism)
14	Special functions	246 – 255: No function 000 – 079: No function 080 – 084: Motor reset all motors 085 – 087: Motor reset pan and tilt 088 – 090: Colour wheel reset 091 – 093: Gobo wheel(s) reset 094 – 096: No function 097 – 099: Other motor reset (gobo rotation, prism, focus) 100 – 119: Automatic show 1 120 – 139: Automatic show 2 140 – 159: Automatic show 3 160 – 179: Automatic show 4 180 – 199: Automatic show 5 200 – 219: Automatic show 6 220 – 239: Automatic show 7 240 – 255: Music controlled show 1
15	Colour wheel changeover time (16-channel mode only)	000 – 255: Max. to min. speed
16	Gobo wheel changeover time (16-channel mode only)	000 – 255: Max. to min. speed

ALURA

Installation & Connection Instructions

Now you know what the Vision 180 Spot is capable of and how it works, we can take a look at how it can be safely and properly installed and connected.

Always ensure that children are unable to access the unit or any connected cables and ensure that any children are supervised by an adult when the unit is in use. Because this unit can be set up in a standing or suspended position, it is possible for children to pull on any connected cables. The unit must be positioned or installed in such a way that this is prevented.

Standing Positioning

When the Vision 180 Spot is set up in a standing position, ensure that the unit is set on a stable surface like a table, DJ booth or bar. The base of the Vision 180 Spot is fitted with feet to improve grip and ensure stability.

Suspended Installation (Suspension Brackets)

When the Vision 180 Spot is suspended, the suspension brackets need to be fitted to the baseplate of the unit. These brackets are fitted via quick-couplers, which are inserted into the mounting points and turned by one quarter to screw them in place. A half-coupler or G-hook can then be secured via the mounting holes of the brackets. Standard hooks and/or brackets for 35mm or 50mm poles (truss or lighting stand) are available via your local retailer.

The hardware required for mounting the Vision 180 Spot to a wall, ceiling or beam does not come included. If you're not sure what hardware you'll need to install the unit, then contact a specialist for advice. Securing the unit to a wooden beam will require different hardware than when securing the unit to a stone wall, for example.

When the Vision 180 Spot is suspended, a safety cable must be used to secure the unit. A safety cable does not come included but will be available via your local retailer.

The Vision 180 Spot comes with a safety eyelet which can be screwed into the base of the unit to secure a safety cable. The safety cable must then be looped over the truss or stand the unit is suspended from before being reattached to the hook.

This way, if one or both of the brackets should fail and come loose, the safety cable will prevent the unit from falling.

A safety cable that's able to bear at least 10x the weight of the unit must be used. The safety cable must be installed so that the unit is unable to fall any further than 30cm. To ensure this, the safety cable can be wrapped around the truss or stand to shorten the length as needed. The shorter the fall-distance allowed by the safety cable, the more the chance of damage or injury is reduced.

Light Source

The Vision 180 Spot comes fitted with powerful LED light modules coupled with a special lens that intensifies the effect. Never look into the lens of the unit from a short distance as the human eye is forced to react too quickly to the sudden intensity of light. Normally, this will not cause permanent injury, but will cause blind spots, impairing vision for a short period of time and causing disorientation and discomfort.

Cooling

The Vision 180 Spot is cooled by fans located in the head and main housing. These will activate

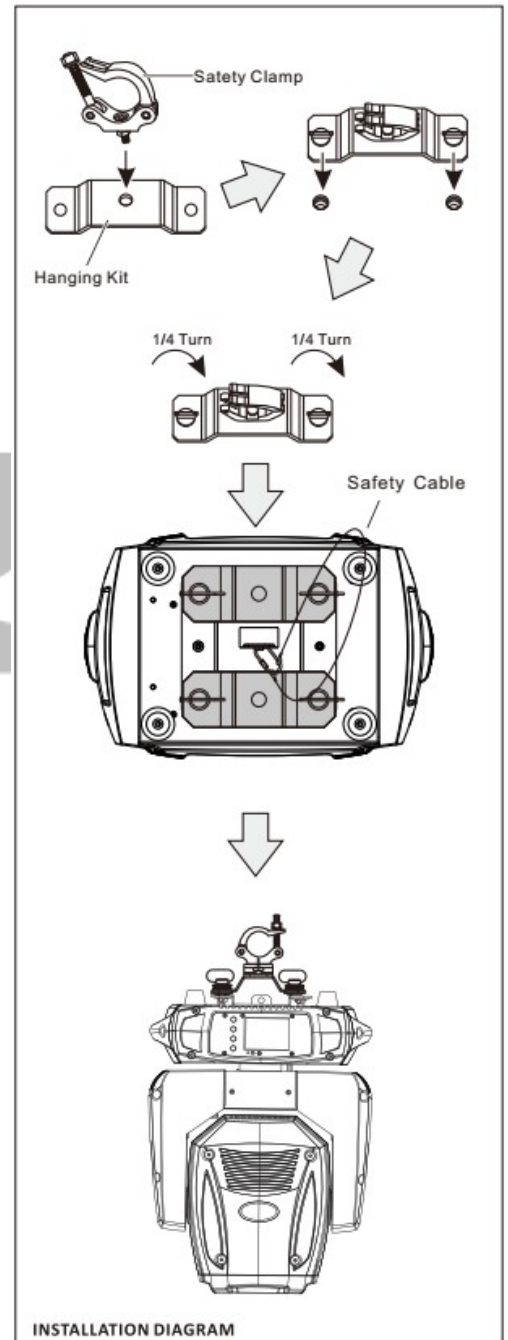

The information included in this user manual is subject to change at any time and without notification:

Version: 1.1 Date & Author Initials: 09-02-2022 RV

Revision Date & Author Initials: -

automatically as soon as the unit is switched on. Always ensure that the fans and ventilation slots are never blocked and regularly check that they are functioning properly. Dust and other elements such as synthetic smoke (precipitated smoke fluid) can affect the functioning and lifespan of the unit.

Temperature-Controlled Fan Systems

This Ayra Vision Series unit is fitted with a built-in temperature-controlled fan system. This system is active as soon as the unit is switched on and will run at a low speed. As the internal temperature of the unit rises, the fan speed will increase to enhance the cooling effect.

The fans will rotate at base speed until the internal temperature reaches approximately 30 degrees Celsius, and will then gradually increase in speed as the temperature rises.

If (for whatever reason) the internal temperature rises to such a level that the fans are unable to sufficiently cool the unit at their maximum speed, the light output of the LED modules will automatically decrease to reduce heat production and regain thermal balance, preventing certain components from overheating.

Parts & Repairs

No spare parts are commercially available for this unit, and therefore it cannot be repaired by the user. In case of any defect, always have the unit inspected and repaired by a qualified technician.

Cleaning & Maintenance

The exterior housing of the unit must be cleaned with a dry or lightly moist microfibre cloth on a monthly basis. Ensure that the unit is unplugged from the power source before cleaning or performing any maintenance.

Check that no screws are missing and that all screws are well secured. Tighten any screws where needed. Check that no corrosion is present on any metal parts of the unit. If any corrosion is present, the unit must be properly inspected.

Use in Daylight/Direct Sunlight

The Vision 180 Spot is fitted with various optics, including a large central lens. If direct sunlight is able to shine through the optics of the unit, there is a danger of sunlight beaming inside the unit itself. This light can be concentrated in such a way that the effect is amplified, causing damage to the interior of the unit. In the worst case, this may cause a fire. Always prevent direct and prolonged sunlight from entering the central lens.

Special DMX Control Features

DMX Terminator & 110 Ohm Impedance Cables

Adding a DMX terminator to the end of your DMX circuit is strongly recommended. This is a termination resistor that is able to counter reflections in the DMX signal and prevent interference. Always use 110 Ohm DMX cables to ensure optimal data signal transfer.

While it may work in practice, unexpected reliability and signal stability issues may arise when this unit is connected using standard XLR microphone cables

High-quality cabling, a stable power supply and the use of DMX terminators all contribute to a more consistent, reliable and safe setup.

DMX Terminator

A DMX terminator is commonly placed at the end of the DMX circuit when using this unit in DMX mode. A DMX terminator places a 120 Ohm resistor between pin 2 and 3 to eliminate any data reflections. Data reflections can cause any DMX fixtures to behave strangely.

Ready-made DMX terminators can be purchased, but a 120 Ohm resistor can be soldered between pin 2 and 3 of a standard M-XLR (male, 3-pin) plug to complete a terminator.

DMX Splitter/Booster

When more than 32 fixtures are chained in one DMX circuit, it is recommended to add a DMX splitter to divide the circuit into several groups. This prevents the signal from becoming too weak, especially when long distances need to be bridged between each fixture.

By using a signal distributor and/or booster, the setup is at a far lower risk of signal distribution problems. This is especially recommended when several fixtures are chained in the same DMX circuit or the DMX signal needs to travel longer distances between fixture groups.

How to Chain Multiple Units

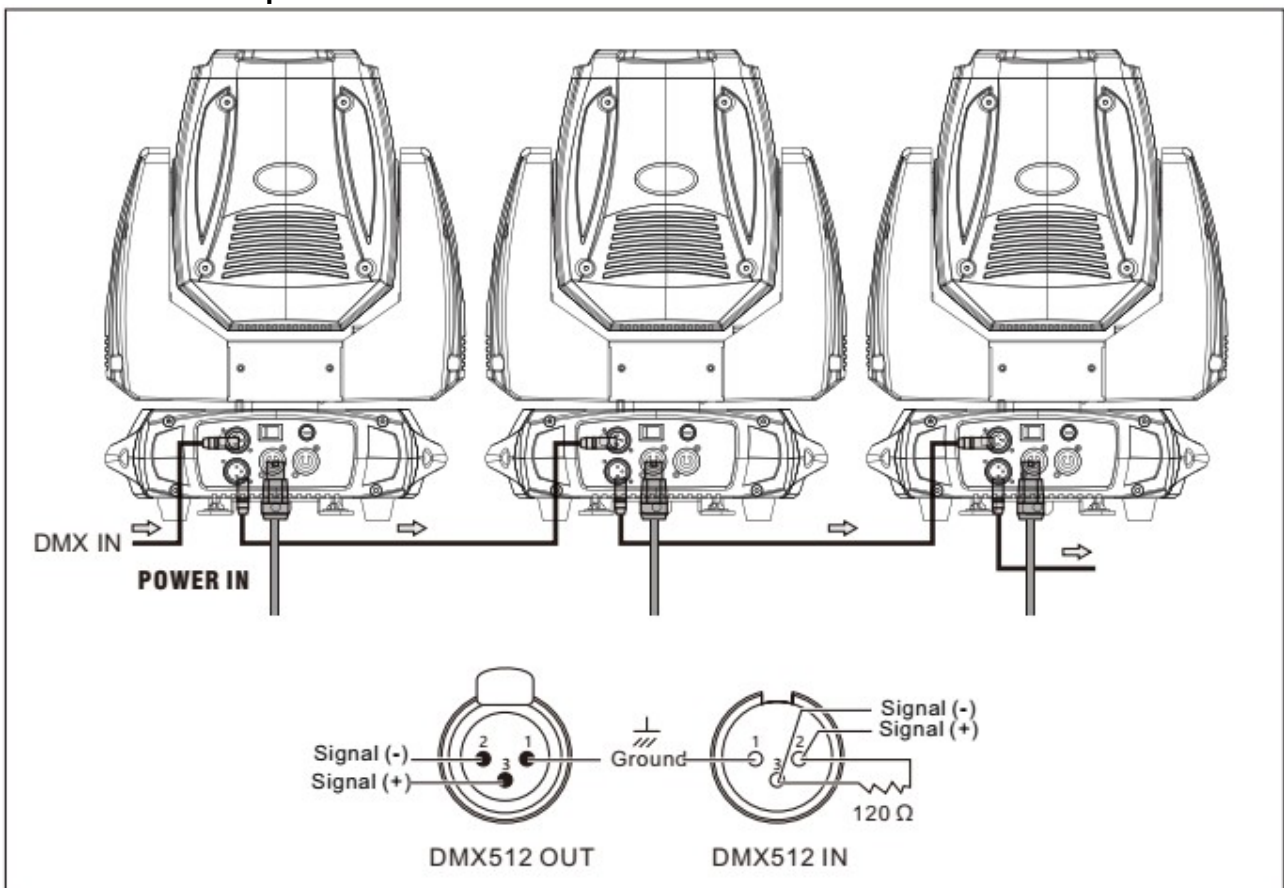

Special Power Output Features

Device Capacity

This device comes with a 3x 1.5mm² thick connecting cable. The internal wiring between the input and output of this unit is 1.5mm².

This unit comes fitted with a power output that can be linked to the following unit to form a chain. A loop-through cable that also has 1.5mm² wiring must be used to link the power output to another unit.

The maximum capacity of the power link output is 16 Amperes, minus the power consumption of the unit

The information included in this user manual is subject to change at any time and without notification:

Version: 1.1 Date & Author Initials: 09-02-2022 RV

Revision Date & Author Initials: -

itself.

This unit has a maximum power consumption rating of 225 Watts which amounts to almost 1 Ampere at 240V, and 2.65A at 100V. To ensure safe operation, and to allow for a margin, it is recommended that a maximum of 12A at 100V or 13A at 240V from the first unit be passed onto the subsequent units.

This means that the total load capacity on the line that supplies the first appliance with power can never exceed 15A.

Always take the capacity of the mains power connection used for the first unit in the line (and any other units in the same line) into account. Because, besides your units, other devices may be connected to the same power group. If this is the case, then the maximum load capacity of the group will be affected, meaning that fewer devices (units, equipment etc) can be connected.

In practice, this means that, a maximum of 4 Ayra Vision 180 Spot units at 100V, or a maximum of 11 Ayra Vision 180 Spot units at 240V, can be chained via the power link output. This is normally more than sufficient for a chain like this, as long as the mains power group is not being used by other electronic devices.

Ideally, other devices (such as heavy strobe lights, smoke machines and so on) that consume more energy than this unit are connected to their own power supply.

The built-in fuse of this unit only protects and fuses the unit itself. If the fuse blows as the result of an electrical fault, the rest of the chain will continue to function normally.

If there is a problem with the unit that affects the entire chain, such as a short-circuit, then normally the mains fuse (usually found in the circuit breaker of the distribution box) of the power group will cut power to all devices connected to that group.

Bear in mind that, if your setup is connected to a third-party system, such as those in an events space, then the power group can only be restored via the electrical meter box.

The installations at these kinds of venues are not usually accessible by third parties. Always check with the venue, or contact the relevant organiser, regarding accessibility in the event of power-outages such as short circuits.

DMX-Lighting Problem Shooting

If you happen to encounter any problems while using this unit, we recommend checking this troubleshooting section to see if a solution can be found. If none of the suggested solutions included below solve your particular problem, please contact your local retailer for further advice.

This troubleshooting section includes all of the most common possible issues and is not a complete list of every possible fault, defect, and their subsequent solution. This section is generally focussed on solving problems regarding DMX lighting. Some of the included problems, causes, and solutions may not apply to your situation since product specifications can differ.

Problem	Possible Cause	Solution
The unit is not switching on	Blown fuse	Check that the fuse is not blown. If it is, replace it with a new fuse of the same rating and type.
	Power cable not plugged in	Make sure that the power cable is securely plugged into the rear of the device and into a mains power socket.
The unit is not responding to DMX signals	Incorrect DMX start address	Make sure that the correct DMX start address is set
	DMX controller set to 'blackout'	Make sure that the 'blackout' function of the DMX controller is switched off.
	The polarity switch of the DMX controller is not correctly set	Try flipping the DMX controller polarity switch.
	Unit not responding. No DMX signal indication	Test the connected cables and replace them if needed.
The unit is not responding to sound/music	Incorrect operating mode	Check that the correct (sound controlled) operating mode is activated.
	Microphone sensitivity level set too low	Check the microphone sensitivity level and increase the value if necessary.
	Speaker is too far away, or not enough lower frequencies (bass)	Place the unit closer to the speaker (or vice versa) and/or enhance lower frequency reproduction of the sound system. The built-in microphone is not triggered by higher frequencies.
The light projection is minimal/weak	Dirty or dusty optics	Clean the lens and/or other optics of the unit
	Dimmer is not fully open	Check that the dimmers of the spots and/or the master dimmers are fully open.
The DMX signal is intermittent and some units are blinking or acting strangely	Broken/defective cables	Test all connected DMX cables and replace any broken or defective cables if necessary.
	Power interference on DMX signal	Avoid installing power cables parallel to DMX signal cables.

The information included in this user manual is subject to change at any time and without notification:

Version: 1.1 Date & Author Initials: 09-02-2022 RV

Revision Date & Author Initials: -

	No DMX terminator	End the DMX circuit with a DMX terminator.
	Signal loss or DMX circuit malfunction	End the DMX circuit with a DMX terminator or connect a booster after every 32 fixtures in the circuit.
The unit is performing jerking movements	Movement is programmed at too slow a speed	When the moving head is set at a very slow speed, movements are performed step by step. In DMX mode this can be corrected slightly by lightly adjusting the pan/tilt speed per unit
Pan or Tilt range is minimal	The pan and tilt range needs to be reset	Check that the pan and tilt range is correctly set on your lighting desk or DMX controller and correct it as needed.
Pan and/or Tilt range are responding the wrong way around	Pan or tilt invert is set	Check that the pan or tilt invert is not set and switch it on or off as needed.
Projected light bundle is not sharp	Optical elements need adjusting	This unit features various elements for optimising or adjusting the optics. Depending on the settings and the space, a shape or beam may not be projected sharply. Via the motorised focus and other optic parameters, the bundle can be sharpened.
Display is mirrored vertically at 180 degrees	Display is inverted so it can be read when unit is suspended	The display can be inverted (flipped upside down) so that it can still be read when the unit is suspended. This function is described earlier in this manual.

The information included in this user manual is subject to change at any time and without notification:

Version: 1.1 Date & Author Initials: 09-02-2022 RV

Revision Date & Author Initials: -

Technical Specifications

Specifications:

- Versatile professional LED moving head
- Spot edition: Fitted with optics to deliver sharp, broad projections
- Light source: 180W LED – 7500K colour temperature
- LED light source lifespan: 50,000 hours
- Various operating modes (automatic, music controlled, DMX, master/slave)
- 14 to 16 DMX-channels
- Offset step-motor calibration

Optic features & Effects

- 3-facet rotating prism, variable rotation speed in both directions
- electronic focus (2.5m to 30m)
- 0-100% linear dimmer
- Built-in LED shutter effect, with strobe function with max. 25 flashes per second
- Built-in shutter-effects, also pulse and random strobe

Pan/Tilt

- Pan-range: 360° / 540° / 630° (540° default)
- Tilt-range: 90° / 180° / 270° (270° default)
- Automatic pan/tilt correction
- Pan and tilt fine option via DMX
- Adjustable pan and tilt movement speed via DMX
- Magnetic zero-point positioning
- Pan and tilt inversion option

Dimmer/Strobe

- 0-100% dimmer
- Various shutter and strobe effects (inc. random strobe)

Colours & Gobos:

- Fixed colour wheel with 7 different colours + open
- Static gobo wheel with 8 gobos + open
- Gobo wheel with 6 rotating gobos
- Built-in wheel-effects (continuous scroll)

Physical Features



- 3- pin XLR DMX inputs and outputs
- Locking power port with Power Link function for chaining and powering units
- Colour display (2.4" TFT) with 4 menu buttons for functions
- Durable housing with plastic caps
- Handles fitted on sides of base
- Base fitted with quick-coupler bracket mounts
- Base fitted with metal eyelet for securing a safety cable during suspended installation
- Can be set up in a standing or suspended position
- Connection voltage: 100 – 240V AC, 50/60Hz
- Max. power consumption: 225W
- Fuse: 20mm glass fuse T4A 250V
- IP20 protection class
- Environmental temperature restrictions: min. -35°C, max 45°C
- Unit dimensions: 307 x 224 x 418mm
- Packaging dimensions: 380 x 250 x 505mm
- Unit net weight: 10.38 kg
- Weight plus packaging: 12.56 kg

The information included in this user manual is subject to change at any time and without notification:

Version: 1.1 Date & Author Initials: 09-02-2022 RV

Revision Date & Author Initials: -

Unit Feature Illustrations:

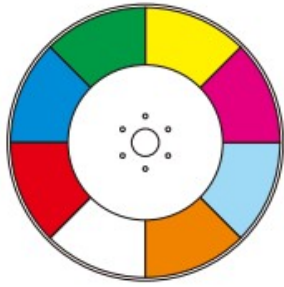
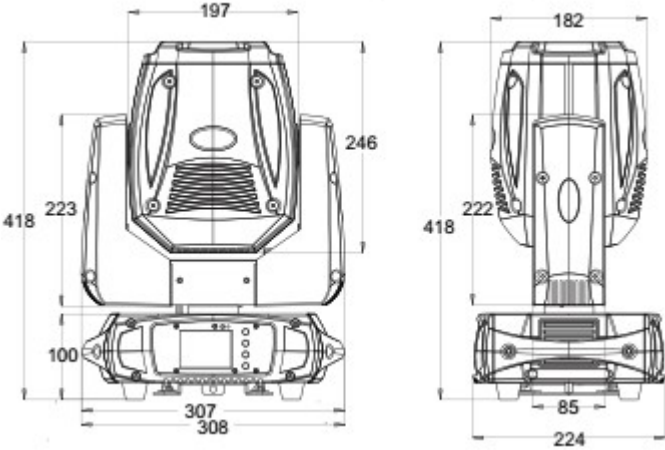
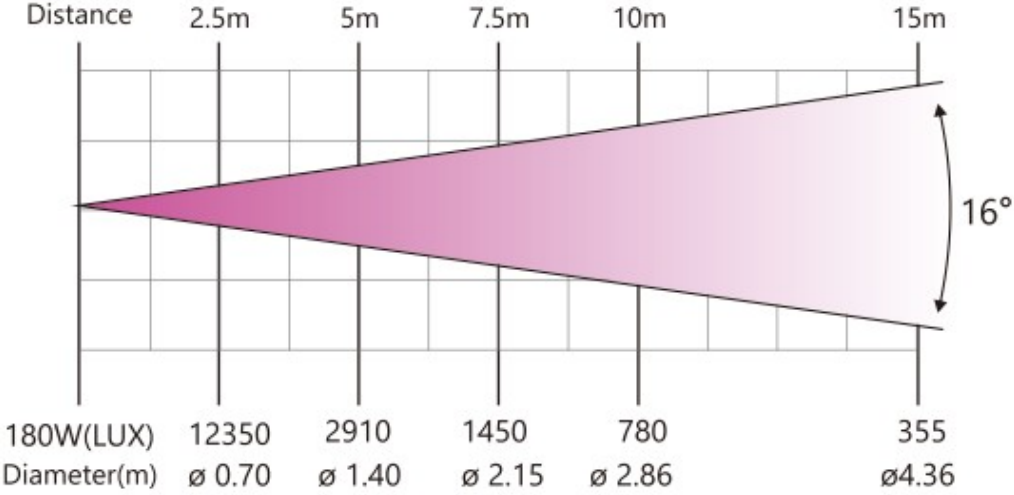
<p>Gobo and Colour Wheels</p>	<div style="display: flex; justify-content: space-around; text-align: center;"> <div> <p>Rotating Gobo Wheel</p>  </div> <div> <p>Static Gobo Wheel</p>  </div> <div> <p>Color Wheel</p>  </div> </div>																		
<p>Unit Dimensions (mm)</p>																			
<p>Photometric Features</p>	 <table border="1" style="width: 100%; text-align: center;"> <thead> <tr> <th>Distance</th> <th>2.5m</th> <th>5m</th> <th>7.5m</th> <th>10m</th> <th>15m</th> </tr> </thead> <tbody> <tr> <td>180W(LUX)</td> <td>12350</td> <td>2910</td> <td>1450</td> <td>780</td> <td>355</td> </tr> <tr> <td>Diameter(m)</td> <td>ø 0.70</td> <td>ø 1.40</td> <td>ø 2.15</td> <td>ø 2.86</td> <td>ø4.36</td> </tr> </tbody> </table>	Distance	2.5m	5m	7.5m	10m	15m	180W(LUX)	12350	2910	1450	780	355	Diameter(m)	ø 0.70	ø 1.40	ø 2.15	ø 2.86	ø4.36
Distance	2.5m	5m	7.5m	10m	15m														
180W(LUX)	12350	2910	1450	780	355														
Diameter(m)	ø 0.70	ø 1.40	ø 2.15	ø 2.86	ø4.36														

The information included in this user manual is subject to change at any time and without notification:

Version: 1.1 Date & Author Initials: 09-02-2022 RV

Revision Date & Author Initials: -