

User's Guide



HDSPe AIO Pro

24 Bit / 192 kHz ✓

TotalMix™



SteadyClock FS™



SyncCheck™

PCI Express Digital I/O Card
AES / SPDIF / ADAT / Analog Interface
24 Bit / 192 kHz Digital Audio
24 Bit / 192 kHz Stereo Analog Input
24 Bit / 192 kHz Dual Stereo Analog Output
High Power² Phones Output
MIDI I/O

Safety Instructions and Proper use



Read the manual carefully and completely before using the device. Pay attention to the following information on how to use and operate the HDSPe AIO Pro safely. Improper use can lead to loss of warranty claims (see warranty statement on page 82).

Proper Use

The HDSPe AIO Pro is a digital interface card for professional audio applications for installation in CE approved class B computers with PCI Express slot.



To comply with the European CE standard, the HDSPe AIO Pro must be used in a CE approved Class B computer. All connecting cables must be shielded. The computer and all cables connected to the HDSPe AIO Pro must be properly grounded. Operation with non-certified computers and cables may cause interference to other devices as well as the HDSPe AIO Pro.

Safety Instructions

The HDSPe AIO Pro Pro has no user-serviceable parts. Repair work must only be carried out by qualified personnel.

The HDSPe AIO Pro must not come into contact with water or humidity. Extreme temperatures must be avoided.

Changes or modifications of the HDSPe AIO Pro Pro not approved by RME may void the warranty and guarantee.



Unauthorized servicing/repair voids warranty. Only use accessories specified by the manufacturer.

► **General**

1	Introduction	8
2	Package Contents	8
3	System Requirements	8
4	Brief Description and Characteristics	8
5	Hardware Installation	9
6	Hardware – Connectors	
6.1	External Connectors	9
6.2	Internal Connectors	10

► **Driver Installation and Operation - Windows**

7	Driver and Firmware	
7.1	Driver Installation	12
7.2	Deinstalling the Drivers	12
7.3	Firmware Update	12
8	Configuring the HDSPe AIO Pro	
8.1	Settings Dialog	13
8.2	Settings Dialog – Pitch	15
8.3	Option WDM Devices	16
8.4	Tab Global	17
8.5	Clock Modes – Synchronization	18
9	Operation and Usage	
9.1	Playback	19
9.2	DVD Playback (AC-3 / DTS)	19
9.3	Channel Count under WDM	20
9.4	Multi-client Operation	20
9.5	Digital Recording	21
9.6	Analog Recording	21
10	Operation under ASIO 2.0	
10.1	General	22
10.2	Channel Count under ASIO	22
10.3	Known Problems	23
11	Using more than one HDSPe AIO Pro	23
12	DIGICheck	24

► **Driver Installation and Operation - Mac OS X**

13	Driver and Flash Update	
13.1	Driver Installation	26
13.2	Driver Update	26
13.3	Flash Update	26
14	Configuring the HDSPe AIO Pro	
14.1	Settings Dialog	27
14.2	Clock Modes – Synchronization	29
15	Mac OS X FAQ	
15.1	MIDI doesn't work	30
15.2	Repairing Disk Permissions	30
15.3	Supported Sample Rates	30
15.4	Channel Count under CoreAudio	30
15.5	Various Information	31
16	Using more than one HDSPe AIO Pro	31
17	DIGICheck	32

► **Connections**

18 Analog Connections

18.1 Line Inputs 34
18.2 Line Outputs 34
18.3 Phones 35

19 Digital Connections

19.1 ADAT 35
19.2 AES/EBU 35
19.3 SPDIF (Coaxial, Optical) 36
19.4 MIDI 36

► **TotalMix FX**

20 Routing and Monitoring

20.1 Overview 40
20.2 The User Interface 42
20.3 The Channels 43
20.4 Section Control Room 46
20.5 The Control Strip 47
 20.5.1 View Options 48
 20.5.2 Snapshots - Groups 49
 20.5.3 Channel Layout – Layout Presets 50
 20.5.4 Scroll Location Markers 51
20.6 Preferences 52
 20.6.1 Store for Current User or all Users 53
20.7 Settings 54
 20.7.1 Mixer Page 54
 20.7.2 MIDI Page 55
 20.7.3 OSC Page 56
 20.7.4 Aux Devices 57
20.8 Hotkeys and Usage 58
20.9 Menu Options 59
20.10 Menu Window 60

21 The Matrix

21.1 Overview 60
21.2 Elements of the Matrix view 60
21.3 Operation 61

22 Tips and Tricks

22.1 ASIO Direct Monitoring (Windows) 61
22.2 Copy a Submix 61
22.3 Doubling the Output Signal (Mirror) 61
22.4 Delete a Submix 62
22.5 Copy and Paste everywhere 62
22.6 Recording a Submix - Loopback 62
22.7 MS Processing 63

23 MIDI Remote Control

23.1 Overview 64
23.2 Mapping 64
23.3 Setup 65
23.4 Operation 65
23.5 MIDI Control 66
23.6 Loopback Detection 67
23.7 OSC (Open Sound Control) 67

24 DAW Mode 68

25 TotalMix Remote 69

► Technical Reference

26	Technical Specifications	
26.1	Analog Inputs	72
26.2	Analog Outputs	72
26.3	Digital Inputs	73
26.4	Digital Outputs.....	73
26.5	Digital	74
26.6	MIDI.....	74
27	Technical Background	
27.1	Lock and SyncCheck	75
27.2	Latency and Monitoring.....	75
27.3	DS – Double Speed	77
27.4	QS – Quad Speed.....	77
27.5	Noise Level in DS / QS Mode	78
27.6	SteadyClock	78
28	Diagrams	
28.1	Block Diagram HDSPe AIO Pro.....	79
28.2	Connector Pinouts	80

► Miscellaneous

29	Accessories	82
30	Warranty	82
31	Appendix	83
32	Declaration of Conformity	84



User's Guide



HDSPe AIO Pro

► General

1. Introduction

Thank you for choosing the RME HDSPe AIO Pro. This unique audio card is capable of transferring digital and analog audio data directly to Windows and Mac computers. The latest Plug and Play technology guarantees a simple installation, even for the inexperienced user. Numerous unique features like a well thought-out Settings dialog and an integrated routing solution realize a quick, comfortable and efficient operation of the HDSPe AIO Pro.

The package contains drivers for Windows (XP, Vista, 7, 8, 10) and Mac OS X x86 (Intel).

2. Package Contents

Please check your HDSPe AIO Pro's package contains each of the following:

- HDSPe AIO Pro PCI Express card
- Quick Info guide
- RME Driver CD
- Digital adapter cable (phono / XLR to D-sub 9-pin)
- Analog adapter cable (phono / phono / TRS / MIDI to D-sub 15-pin)
- Internal cable (3-core)
- 1 optical cable (TOSLINK)

3. System Requirements

- Windows XP or higher, Mac OS X Intel (10.6 or higher)
- PCI Express Interface: one free PCI Express slot, 1 Lane, version 1.1

4. Brief Description and Characteristics

- All settings can be changed in real-time
- Analog, ADAT and SPDIF I/Os can be used simultaneously
- AES and SPDIF I/Os can be used simultaneously
- Buffer sizes/latencies from 32 up to 8192 samples selectable
- 4 channels 96 kHz/24 bit record/playback via ADAT optical (S/MUX)
- 2 channels 192 kHz/24 bit Record/Playback via ADAT optical (S/MUX4)
- Automatic and intelligent master/slave clock control
- Unsurpassed Bitclock PLL (audio synchronization) in ADAT mode
- SteadyClock FS: Jitter-immune, super-stable digital clock
- DDS technology for free setting of the sample rate
- TotalMix for latency-free submixes and perfect ASIO Direct Monitoring
- TotalMix: 448 channel mixer with 46 bit internal resolution
- SyncCheck tests and reports the synchronization status of input signals
- 1 x MIDI I/O, 16 channels high-speed MIDI
- DIGICheck DSP: Level meter in hardware, peak- and RMS calculation
- 1 x stereo analog Line In with 4 hardware reference levels
- 1 x stereo analog Line Out with 4 hardware reference levels
- 1 x stereo analog Line/Headphone Out, separate output for independent submix
- Powerful High Power² phones output with switchable High/Low mode
- Optional Time Code module (TCO) for external Video-/SMPTE synchronization
- Optional Word Clock Module for word clock input and output

5. Hardware Installation

To simplify installation it is recommended to first install the drivers before the unit is connected to the computer. But it will also work the other way round.

! *Before installing the PCI Express card, please make sure the computer is switched off and the power cable is disconnected from mains supply. Inserting or removing the card while the computer is in operation can cause irreparable damage to both motherboard and card!*

1. Disconnect the power cord and all other cables from the computer.
2. Remove the computer's housing. Further information on how to do this can be obtained from your computer's instruction manual.
3. Important: Before removing the HDSPe AIO Pro from its protective bag, discharge any static in your body by touching the metal chassis of the PC.
4. Prior to installation: Connect the HDSPe AIO Pro card to any Expansion Board (if present) using the supplied flat ribbon cable. Please read the Expansion Board's manual for more details.
5. Insert the HDSPe AIO Pro firmly into a free PCI Express slot, press and fasten the screw.
6. If present, insert the Expansion Board(s) and fasten the screw(s).
7. Replace the computer's housing.
8. Reconnect all cables including the power cord.

6. Hardware - Connectors

6.1 External Connectors

The bracket of the HDSPe AIO Pro has one **ADAT optical** input and output, a **9-pin** and a **15-pin D-sub** socket. The included **breakout cables** provide all the analog and digital connections.

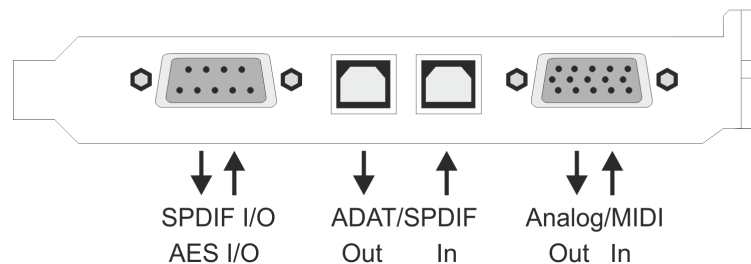

The **ADAT I/O** can also be used as **optical SPDIF I/O**, if set up accordingly in the Settings dialog.

The 9-pin **digital** breakout cable has two **RCA** connectors as coaxial **SPDIF I/O** (the **red** phono socket is the **output**), and an **XLR AES/EBU** input and output.

The 15-pin **analog** breakout cable has four **RCA** connectors (stereo analog I/O), a 1/4" **TRS** jack (headphones), and two 5-pin **DIN** connectors (MIDI I/O). Using the optional analog XLR breakout cable BO9632-XLRMKH, the HDSPe AIO Pro offers **balanced Line** inputs and outputs via female and male **XLR** connectors.

Optional HDSPe AIO Pro Word Clock Module

The expansion board *HDSPe AIO Pro Word Clock Module* provides one word clock input and two word clock outputs. A green LED signals the **LOCK** state of the word clock input stage. A small push switch allows to activate 75 Ohm termination for the word clock input. The yellow LED is lit when termination is active.

Optional TCO

The time code option has one word clock and LTC input and output each on its slot bracket. Under Windows the TCO provides the SMPTE position information in APP (ASIO Positioning Protocol) and as MTC Sync. The LTC output requires communication via ASIO PP. Under Mac OS X the TCO provides the SMPTE position in MTC Sync, the LTC output is without function.

6.2 Internal Connectors

INT (X1202)

This internal digital input can be used with both SPDIF and ADAT format. It is activated by selecting *SPDIF In – Internal* in the Settings dialog.

SPDIF

- Connection to an internal CD-ROM drive with digital audio output. Allows for a direct transfer of digital audio data within the computer.
- Connection to an SPDIF output of another card. This internal SPDIF connection can be used to synchronize multiple cards with sample accuracy, and without the need for an external connection. Please note that the coaxial SPDIF input can no longer be used.

ADAT

- In this mode the optical input can only be used as optical SPDIF input.

SYNC IN (X400)

Internal word clock input for synchronization of multiple cards via SYNC OUT of another card.

SYNC OUT (X401)

This 3-pin connector carries an internal word clock signal. It can be used to synchronize multiple cards with sample accuracy, and without the need for an external connection. The card where SYNC OUT is used is Master, the one with SYNC IN is Slave. In the Settings dialog the Slave has to be set to *Sync In* under *Clock Source*.

WCM / TCO (X402)

10-pin connector to connect the optional Word Clock Module or the optional Time Code Option (TCO) via flat ribbon cable.

Digital I/O (X1201)

This 10-pin header allows internal access to all pins of the 9-pin D-Sub, and thus to the AES and SPDIF I/Os of the card. Pin assignment of the pin header:

Pin	Name	Pin	Name	Pin	Name
1	SPDIF Out - / GND	3	SPDIF In -	5	AES Out +
4	SPDIF Out +	10	AES In +	8	AES Out -
6	SPDIF In +	7	AES In -	9	Not connected

User's Guide



HDSPe AIO Pro

► Driver Installation and Operation - Windows

7. Driver and Firmware

7.1 Driver Installation

After the HDSPe AIO Pro card has been installed correctly (see 5. Hardware Installation), and the computer has been switched on, Windows will recognize the new hardware component and start its 'Hardware Wizard'. In case the drivers had not been installed before exit the assistant.

RME is constantly improving the drivers. Please download the latest drivers from the RME website. Driver version 4.30 or higher is available via <http://rme.to/downloads>. Unzip the downloaded file and start the driver installation with *rmeininstaller.exe*. Windows detects the new hardware as **HDSPe AIO Pro** and installs the drivers automatically. After a reboot the card is ready to be used.

After the reboot, the icons of TotalMix FX and Settings dialog appear in the notification area. Windows might hide them behind the triangle, click on it to access them and to configure their appearance.

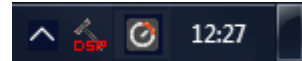

Driver Updates do not require to remove the existing drivers. Simply install the new driver over the existing one.

7.2 Deinstalling the Drivers

A deinstallation of the HDSP's driver files is not necessary – and not supported by Windows anyway. Thanks to full Plug & Play support, the driver files will not be loaded after the hardware has been removed. If desired these files can then be deleted manually.

Unfortunately Windows Plug & Play methods do not cover the additional autorun entries of TotalMix, the Settings dialog, and the registration of the ASIO driver. Those entries can be removed from the registry through a software deinstallation request. This request can be found (like all deinstallation entries) in *Control Panel, Software*. Click on the entry 'RME Hammerfall DSP (WDM)'.

7.3 Firmware Update

The Flash Update Tool updates the HDSPe AIO Pro to the latest firmware version. It requires an already installed driver.

Start the program **pcie_fut.exe**. The Flash Update Tool displays the current revision of the HDSPe AIO Pro, and whether it needs an update or not. If so, then please press the 'Update' button. A progress bar will indicate when the flash process is finished. The bar moves slowly first (program), then faster (verify).

If more than one interface card is installed, all cards can be flashed by changing to the next tab and repeating the process.

After the update the PCI Express card needs to be reset. This is done by powering down and shutting off the PC. A warm boot is not enough!

When the update fails (status: failure), the card's second BIOS will be used from the next cold boot on (Secure BIOS Technology). Therefore the card stays fully functional. The flash process should then be tried again on a different computer.

8. Configuring the HDSPe AIO Pro

8.1 Settings Dialog

Configuration of the HDSPe AIO Pro is done via its own settings dialog. The panel 'Settings' can be opened:

- by clicking on the hammer symbol in the Task Bar's system tray

The mixer of the Hammerfall DSP Systems (TotalMix) can be opened:

- by clicking on the mixer icon in the Task Bar's system tray

The hardware of the HDSP system offers a number of helpful, well thought-of practical functions and options which affect how the card operates - it can be configured to suit many different requirements. The following is available in the 'Settings' dialog:

- Input selection
- Level of analog I/Os
- Configuration of digital I/Os
- Synchronization behaviour
- State of input and output
- Current sample rate
- Latency

Any changes made in the Settings dialog are applied immediately - confirmation (e.g. by clicking on OK or exiting the dialog) is not required.

However, settings should not be changed during playback or record if it can be avoided, as this can cause unwanted noises.

Also, please note that even in 'Stop' mode, several programs keep the recording and playback devices open, which means that any new settings might not be applied immediately.

The status displays at the bottom of the dialog box give the user precise information about the current status of the system, and the status of all digital signals.

The tab **About** includes information about the current driver version.

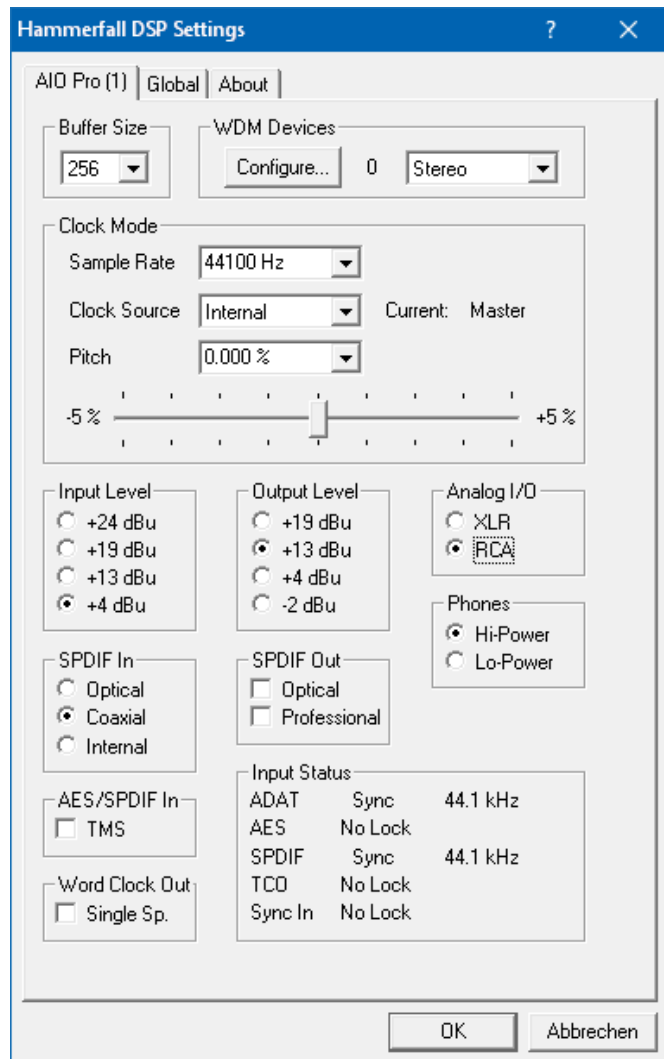

Buffer Size

The setting *Buffer Size* determines the latency between incoming and outgoing ASIO and WDM data, as well as affecting system stability (see chapter 13.1). While ASIO can use any offered buffer size, WDM is limited to 256 (XP) or 512 samples (Win 7/8). The driver handles this automatically, higher settings are only applied to ASIO while WDM will stay at 256/512 internally.

WDM Devices

Allows to freely set which I/Os are available as WDM devices, if these are stereo or multi-channel devices (up to 8 channels), and if one or multiple of the currently active WDM devices should have the Speaker property. More details are found in chapter 11.2.

Clock Mode

Sample Rate

Sets the currently used sample rate. Offers a central and comfortable way of configuring the sample rate of all WDM devices to the same value, as since Vista the audio software is no longer allowed to set the sample rate. However, an ASIO program can still set the sample rate by itself.

During record/playback the selection is greyed out, so no change is possible.

Clock Source

The unit can be configured to use its own clock (Internal = Master), or one of the input signals (ADAT, AES, SPDIF, TCO, Sync In). If the selected source isn't available (No Lock), the unit will change to the next available one (RME's AutoSync behaviour). If none is available then the internal clock is used. The current clock source is displayed as *Current*.

Pitch

More information on Pitch is available in chapter 11.4.

Input Level

Choice of the analog reference level for full level (0 dBFS), and therefore the sensitivity of the analog Line input.

Output Level

Choice of the analog reference level for 0 dBFS and therefore the level at the analog Line output.

Analog I/O (Breakout cable)

Choose the setting that equals the breakout cable currently in use. A wrong setting will cause incorrect reference levels.

SPDIF In

Defines the input for the SPDIF signal. 'Optical' relates to the optical TOSLINK input, 'Coaxial' to the RCA socket, 'Internal' to the jumper SPDIF IN.

SPDIF Out

The SPDIF output signal is constantly available at the phono plug. After selecting 'Optical' it is also routed to the optical TOSLINK output. Details about 'Professional' see chapter 23.3.

Phones

Choice of the reference level and with this of the level at the analog phones output. Lo-Power offers reduced background noise which is useful with highly sensitive headphones.

AES/SPDIF In

TMS activates the transmission of Channel Status data and Track Marker information from the SPDIF and AES input to DIGICheck, see chapter 12.

Word Clock Out

The word clock output signal usually equals the current sample rate. Selecting *Single Speed* causes the output signal to always stay within the range of 32 kHz to 48 kHz. So at 96 kHz sample rate, the output word clock is 48 kHz.

Input Status

SyncCheck indicates whether there is a valid signal (Lock, No Lock) for each input (ADAT, SPDIF, AES, Word/TCO and internal Sync), or if there is a valid *and* synchronous signal (Sync).

In the third row the sample rate measured by the hardware is shown.

8.2 Settings dialog - Pitch

Usually soundcards and audio interfaces generate their internal clock (master mode) by a quartz. Therefore the internal clock can be set to 44.1 kHz or 48 kHz, but not to a value in between. SteadyClock, RME's sensational Low Jitter Clock System, is based on a *Direct Digital Synthesizer* (DDS). This superior circuitry can generate nearly any frequency with highest precision.

DDS has been implemented into the HDSPe AIO Pro with regard to the needs of professional video applications, as well as to achieve maximum flexibility. The section Pitch includes both a list of typical video frequencies (so called pull up/pull down at 0.1% and 4%) and a fader to freely change the basic sample rate in steps of 1 Hz (!) over a range of +/- 5%.

- ! *The DDS dialog requires the HDSPe AIO Pro to be in clock mode Master! The frequency setting will only be applied to this one specific card!*
- ! *Changing the sample rate in bigger steps during record/playback often results in a loss of audio, or brings up warning messages of the audio software. Therefore the desired sample rate should be set at least coarsely before starting the software.*

Coarse

Coarse modification in steps of 50 Hz is done by clicking with the mouse to the left and right of the fader knob.

Fine

Fine modification in steps of 1 Hz is done by using the left/right cursor keys.

Reset

Ctrl key plus left mouse click.

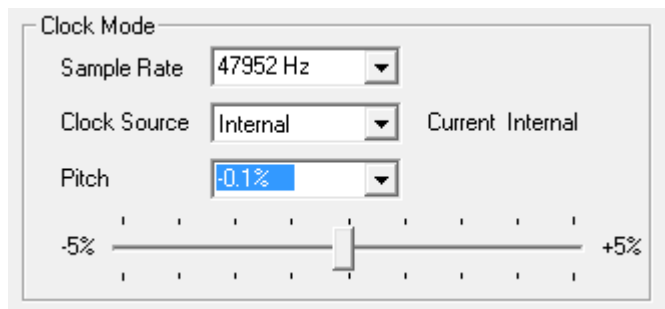

Application examples

Pitch allows for a simultaneous change of speed and tune during record and playback. From alignment to other sources up to creative effects – everything is possible.

Pitch enables you to intentionally de-tune the complete DAW. This way, the DAW can match instruments which have a wrong or unchangeable tuning.

Pitch allows for the change of the sample rate of all WDM devices at the same time. Since Vista this is no longer possible via the audio program, thus requires a manual reconfiguration of all WDM devices. Changing the sample rate from the Settings dialog solves this problem.

8.3 Option WDM Devices

The area WDM Devices gives configuration access, a status display showing the number of currently enabled WDM devices, and a listbox to select between *Stereo* or *Multi-Channel* devices.

The number represents both record and playback devices, so '1' means one input and one output device.

The screenshot to the right shows the stereo WDM devices available with the HDSPe AIO Pro, and that only Analog 1/2 has been activated. Any number can be activated. Also only higher numbered devices might be active. For example using the output ADAT 1/2 for system based audio does not require to activate AES, Phones and Analog 1/2. Only ADAT 1/2 will show up in the Windows Sound control panel.

The checkbox *All* to the right allows for a quick check/uncheck of all devices.

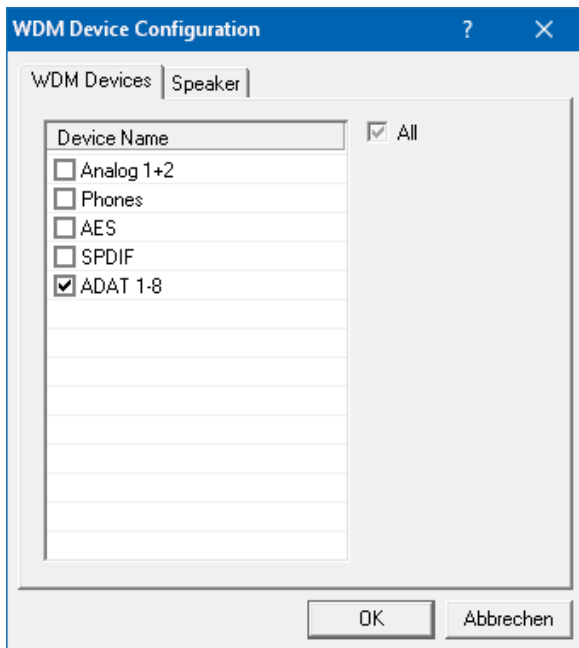
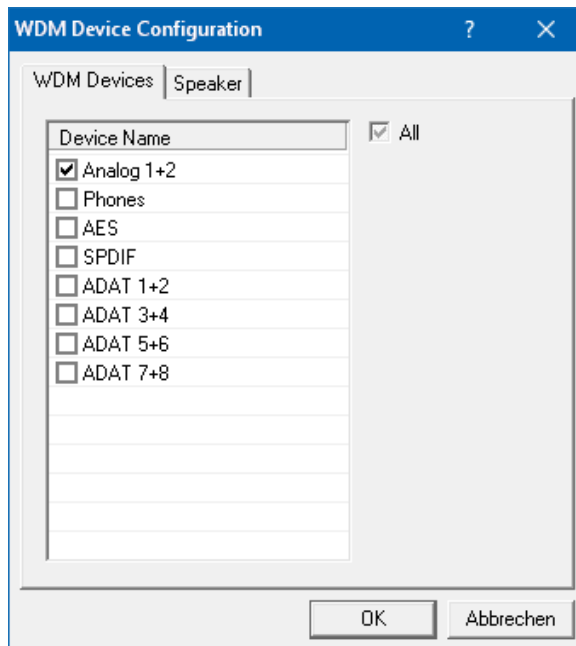

The screenshot to the left shows the multi-channel WDM devices available with the HDSPe AIO Pro after selecting 'Multi-Channel' in the WDM Devices listbox and hitting *WDM Configure*. In this example the devices *ADAT 1 to 8* are active.

Using a multi-channel WDM device allows for the use of multi-channel playback with specialized software as well as Surround sound from DVD or Bluray player software.

Changing to the tab *Speaker* presents a list of all currently activated WDM devices. Any of these can now get the *Speaker* property.

Please note that defining more than one device as *Speaker* usually makes no sense, and the speakers also don't get numbered or renamed in Windows, so it is impossible to find out which one is which.

With the HDSPe AIO Pro stereo devices (Analog, AES, SPDIF) are limited to 2 channels even when used as multichannel devices. Only ADAT 1-8 can be addressed as 2-channel, 4-channel, 6-channel or 8-channel device after multichannel assignment.

After leaving the dialog with OK the WDM devices are reloaded so Windows sees their new properties.

8.4 Tab Global

This tab includes several options that work on all currently installed cards.

Lock Registry

Default: off. Checking this option brings up a dialog to enter a password. Changes in the Settings dialog are no longer written to the registry. As the settings are always loaded from the registry when starting the computer, this method provides an easy way to define an initial state of the MADiface XT.

Optimize Multi-Client Mixing

Default: off. Checking this option removes short noise bursts when multi-client playback starts, but will also introduce some additional CPU load.

DirectMusic MIDI

Disables DirectMusic MIDI. Windows MIDI remains active.

Alt. Multi-Card Mode

Activates an alternative multi-card mode in which when one card is started, the other card is always started as well. This prevents audio problems in mixed ASIO/WDM mode, such as no ASIO sound on the first card when WDM is started on the second.

Enable MMCSS for ASIO activates support with higher priority for the ASIO driver. Note: At this time, activating this option seems to be useful only with the latest Cubase/Nuendo at higher load. With other software this option can decrease performance. The change becomes active after an ASIO reset. Therefore it is easy to quickly check which setting works better.

ASIO 32 Channel Limit

Default: off. Checking this option limits the number of ASIO I/Os to 32. Reducing the number of ASIO channels can be helpful in certain situations, but is usually not valid for the AIO Pro (only 16 channels).

Change Card Order

This dialog lists all cards currently installed in the system and controlled by the driver. Their order can then be changed by selecting a card and using the up/down arrows. Confirm the operation with the Apply button. This feature comes in handy if different cards are installed and a specific one of them should always be the first in the ASIO channel list.

At the end of the card info line the current firmware version is shown (Revision).

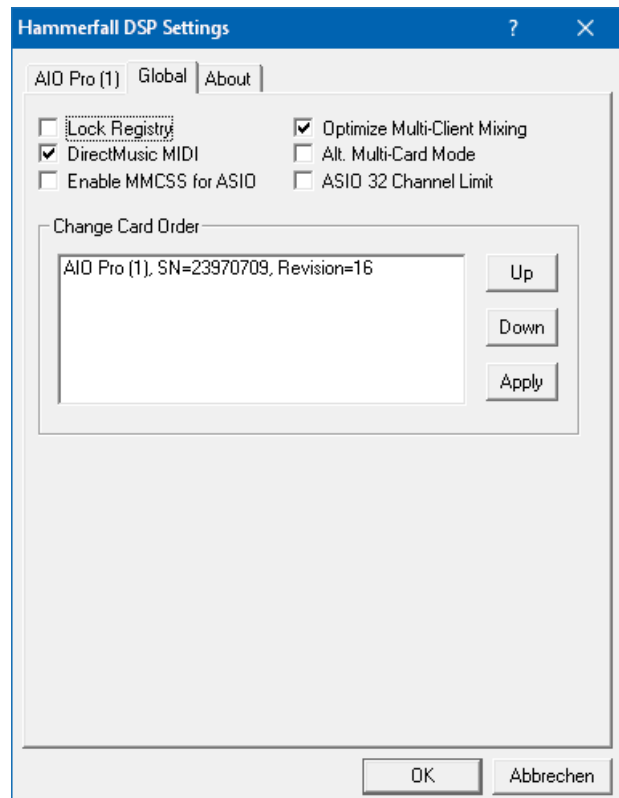

8.5 Clock Modes - Synchronisation

In the digital world, all devices must be either Master (clock source) or Slave (clock receiver). Whenever several devices are linked within a system, there must always be a single master clock.

! *A digital system can only have one master! If the card's clock mode is set to 'Internal', all other devices must be set to 'Slave'.*

The HDSPe AIO Pro's utilizes a very user-friendly, intelligent clock control, called **AutoSync**. In AutoSync mode, the system constantly scans the digital input for a valid signal. If any valid signal is found, the card switches from the internal clock (*Clock Mode – Current Internal*) to a clock extracted from the input signal (*Clock Mode – Current ADAT, AES, SPDIF or Sync In*). The difference to a usual slave mode is that whenever the clock reference fails, the system will automatically use its internal clock and operate in clock mode Master.

AutoSync guarantees that normal record and record-while-play will always work correctly. In certain cases however AutoSync may cause feedback in the digital carrier, so synchronization breaks down. To remedy this, switch the HDSP's clock mode over to 'Internal'.

RME's exclusive **SyncCheck** technology enables an easy to use check and display of the current clock status. The status box labelled *Input Status* indicates whether no signal ('No Lock'), a valid signal ('Lock') or a valid *and* synchronous signal ('Sync') is present at each of the digital clock source inputs. In the field *Clock Mode* the clock reference is shown. See chapter 30.1.

Via *Clock Source* a preferred input can be defined. As long as the card sees a valid signal there, this input will be designated as the sync source, otherwise the other inputs will be scanned in turn. If none of the inputs are receiving a valid signal, the HDSPe automatically switches into clock mode Master.

Under WDM the unit will (has to) set the sample rate. Therefore the error shown to the right can occur. A stable signal with a sample rate of 32 kHz is detected at the Word Clock input (Sync), but Windows audio had been set to 44100 Hz before. The red colour of the text label signals the error condition, and prompts the user to set 32000 Hz manually as sample rate.

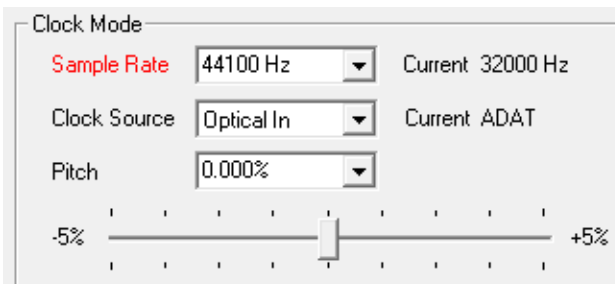

Under ASIO the audio software sets the sample rate, so that such an error will usually not happen – but it can too. In slave mode the external sample rate has priority. Feeding 44.1 kHz will prevent the ASIO software to set 48 kHz – obviously, as the only way to do so would be to enter a different clock mode (Master/Internal).

In practice, SyncCheck provides the user with an easy way of checking whether all digital devices connected to the system are properly configured. With SyncCheck, finally anyone can master this common source of error, previously one of the most complex issues in the digital studio world.

9. Operation and Usage

9.1 Playback

In the audio application being used, HDSPE AIO Pro must be selected as output device. This can often be found in the *Options, Preferences* or *Settings* menus under *Playback Device, Audio Devices, Audio* etc.

! *WDM playback devices are not available if the number of WDM devices is set to 0 in the Settings dialog.*

Although the AIO Pro comes with extensive support for system audio, setting it to be the *Default Device* for playback could cause problems, especially when working with ASIO. RME also recommends switching off all system sounds (via Control Panel *Sound*, tab *Sounds*).

Increasing the number and/or size of audio buffers may prevent the audio signal from breaking up, but also increases latency i.e. output is delayed. For synchronized playback of audio and MIDI (or similar), be sure to activate the checkbox 'Get position from audio driver'.

Note: Since Vista the audio application can no longer control the sample rate under WDM. Therefore the driver of the HDSPE AIO Pro includes a way to set the sample rate globally for all WDM devices, found within the Settings dialog. See chapter 7.1.

9.2 DVD-Playback (AC-3/DTS) under MME

Popular DVD software players can send their audio data stream to any AC-3/DTS capable receiver via the HDSPE's SPDIF or AES output.

! *The sample rate must be set to 48 kHz in the AIO Pro's Settings dialog, or the software will only playback a stereo 2-channel downmix via SPDIF.*

In some cases the HDSPE AIO Pro output device has to be selected in *>Control Panel / Sound / Playback<* and be set as *Default*, or the software will not recognize it.

The DVD software's audio properties now show the options 'SPDIF Out' or similar. When selecting it, the software will transfer the non-decoded digital multi-channel data stream to the AIO Pro SPDIF output.

Warning: This 'SPDIF' signal sounds like chopped noise at highest level.

Multichannel

PowerDVD and WinDVD can also operate as software decoder, sending a DVD's multichannel data stream directly to the analog outputs of the HDSPE AIO Pro. For this to work select the WDM playback device 'Loudspeaker' of the AIO Pro in *Control Panel, Sound*, tab *Playback* as *Default*.

PowerDVD's and WinDVD's audio properties now list several multichannel modes. If one of these is selected, the software sends the decoded analog multichannel data to the AIO Pro. TotalMix can then be used to play back via any desired output channels, even the digital ones like ADAT.

The typical channel assignment for surround playback is:

1 – Left 2 – Right 3 – Center 4 - LFE (Low Frequency Effects)
5 - SL (Surround Left) 6 - SR (Surround Right)

Note 1: Selecting the AIO Pro to be used as system playback device is against our recommendation, as professional interfaces should not be disturbed by system events. Make sure to re-assign the selection after usage or to disable any system sounds (tab Sounds, scheme 'No audio').

Note 2: The DVD player will be synced backwards from the AIO Pro. This means when using AutoSync and/or word clock, the playback speed and pitch follows the incoming clock signal.

9.3 Channel Count under WDM

The HDSPe's ADAT optical interfaces allow to record sample rates of up to 192 kHz using a standard ADAT recorder. For this to work single-channel data is spread to two or four ADAT channels using the *Sample Multiplexing* technique. This reduces the number of available ADAT channels from 8 to 4 or 2 per ADAT port.

WDM Stereo device	Double Speed	Quad Speed
AIO Analog (1+2)	AIO Analog (1+2)	AIO Analog (1+2)
AIO Phones*	AIO Phones*	AIO Phones*
AIO AES	AIO AES	AIO AES
AIO SPDIF	AIO SPDIF	AIO SPDIF
AIO ADAT (1+2)	AIO ADAT (1+2)	AIO ADAT (1+2)
AIO ADAT (3+4)	AIO ADAT (3+4)	AIO ADAT (3+4)
AIO ADAT (5+6)	AIO ADAT (5+6)	AIO ADAT (5+6)
AIO ADAT (7+8)	AIO ADAT (7+8)	AIO ADAT (7+8)

* Phones output, playback only.

9.4 Multi-client Operation

RME audio interfaces support multi-client operation. Several programs can be used at the same time. The formats ASIO and WDM can even be used on the same playback channels simultaneously. As WDM uses a real-time sample rate conversion (ASIO does not), all active ASIO software has to use the same sample rate.

However, a better overview is maintained by using the channels exclusively. This is no limitation at all, because TotalMix allows for any output routing, and therefore a playback of multiple software on the same hardware outputs.

Inputs can be used from an unlimited number of WDM and ASIO software at the same time, as the driver simply sends the data to all applications simultaneously.

RME's sophisticated tool *DIGICheck* operates like an ASIO host, using a special technique to access playback channels directly. Therefore DIGICheck is able to analyse and display playback data from any software, no matter which format it uses.

9.5 Digital Recording

Unlike analog soundcards which produce empty wave files (or noise) when no input signal is present, digital I/O cards always need a valid input signal to start recording.

To take this into account RME included a comprehensive I/O signal status display (showing sample frequency, lock and sync status) in the Settings dialog.

The sample frequency shown in the Settings dialog (see chapter 8.1, screenshot Settings) is useful as a quick display of the current configuration (the card itself and all connected external equipment). If no sample frequency is recognized, it will read *No Lock*.

This way, configuring any suitable audio application for digital recording is simple. After selecting the required input, HDSPe AIO Pro displays the current sample frequency. This parameter can then be changed in the application's audio attributes (or similar) dialog.

It often makes sense to monitor the input signal or send it directly to the output. This can be done at zero latency using **TotalMix** (see chapter 24).

An *automated* control of real-time monitoring can be achieved by Steinberg's ASIO protocol with RME's ASIO drivers and all ASIO compatible programs. When 'ASIO Direct Monitoring' has been switched on, the input signal is routed in real-time to the output whenever a recording is started (punch-in).

9.6 Analog Recording

For recordings via the analog inputs the corresponding record device has to be chosen (AIO Analog (x+x)).

The input sensitivity of the analog inputs can be adjusted via the Settings dialog to meet the most often used studio levels, see chapter 22.1. The level of the input signal, and if it is too hot or too low in level, can be checked via the input level meters in TotalMix FX.

10. Operation under ASIO 2.0

10.1 General

Start the ASIO software and select **ASIO Hammerfall DSP** as the audio I/O device.

The HDSP system supports *ASIO Direct Monitoring* (ADM).

The HDSPe AIO Pro MIDI I/O can be used with both Windows MIDI and Direct-Music MIDI.

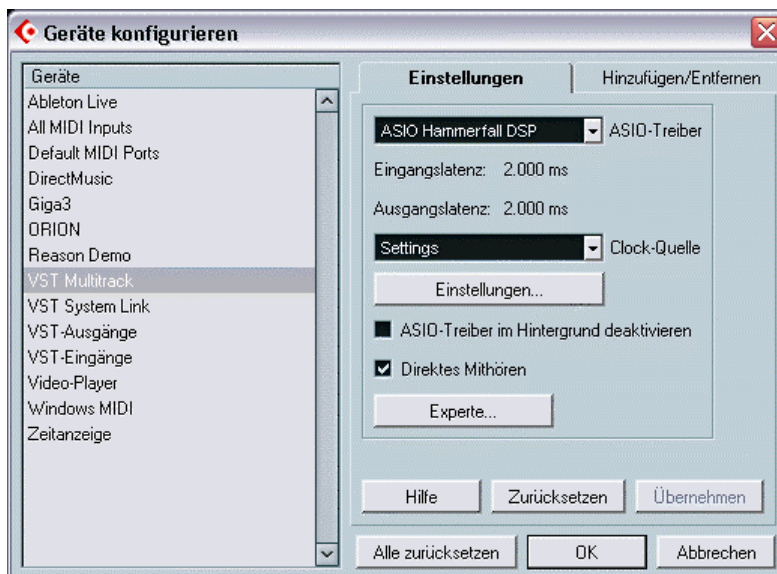

10.2 Channel Count under ASIO

At a sample rate of 88.2 or 96 kHz, the ADAT optical input and outputs operate in S/MUX mode, so the number of available channels per port is reduced from 8 to 4.

At a sample rate of 176.4 and 192 kHz, the ADAT optical input and outputs operate in S/MUX4 mode, so the number of available channels per port is limited to 2.

Please note that when changing the sample rate range between Single, Double and Quad Speed the number of channels presented from the ASIO driver will change too. This may require a reset of the I/O list in the audio software.

Mono channel	Double Speed	Quad Speed
AIO Analog 1/2	AIO Analog 1/2	AIO Analog 1/2
AIO AES L / R	AIO AES L / R	AIO AES L / R
AIO SPDIF L / R	AIO SPDIF L / R	AIO SPDIF L / R
AIO ADAT 1 to 2	AIO ADAT 1 to 2	AIO ADAT 1 to 2
AIO ADAT 3 to 4	AIO ADAT 3 to 4	AIO ADAT 3 to 4
AIO ADAT 5 to 8	AIO ADAT 5 to 8	AIO ADAT 5 to 8

The phones output (AIO Phones L / R) is only available as output.

10.3 Known Problems

If a computer does not provide sufficient CPU-power and/or sufficient PCIe-bus transfer rates, then drop outs, crackling and noise will appear. We recommend to deactivate all PlugIns to verify that these are not the reason for such effects.

A typical source of trouble is incorrect synchronization. ASIO does not support asynchronous operation, which means that the input and output signals not only have to use the same sample frequency, but also have to be in sync. All devices connected to the HDSPe must be properly configured for Full Duplex operation. As long as SyncCheck (in the Settings dialog) only displays *Lock* instead of *Sync*, the devices have not been set up properly!

When using more than one HDSPe system, all units have to be in sync. Else a periodically repeated noise will be heard.

RME supports *ASIO Direct Monitoring* (ADM). Please note that not all programs support ADM completely or error-free. The most often reported problem is the wrong behaviour of panorama in a stereo channel. Also try to avoid setting the TotalMix FX hardware outputs (third row) to mono mode. This will most likely break ADM compatibility.

In case of a drift between audio and MIDI, or in case of a fixed deviation (MIDI notes placed close before or behind the correct position), the settings in Cubase/Nuendo have to be changed. At the time of print the option 'Use System Timestamp' should be activated. The HDSPe system supports Windows MIDI and DirectMusic MIDI. Which one works better depends on the respective application.

11. Using more than one HDSPe AIO Pro

The current drivers support operation of up to three HDSPe AIO Pro. All cards of the HDSP and HDSPe system use the same driver, therefore can be used at the same time. Please note that only one TCO of one card can be used. All units have to be in sync, i.e. have to receive valid sync information either via word clock or by using AutoSync and feeding synchronized signals.

- If one of the HDSPe systems is set to clock mode Master, all others have to be set to clock mode Slave, and have to be synced from the master device, for example by feeding word clock. The clock modes of all units have to be set up correctly in their Settings dialog.
- If all units are fed with a synchronous clock, i.e. all units show *Sync* in their Settings dialog, all channels can be used at once. This is especially easy to handle under ASIO, as the ASIO driver presents all cards as one.

Note: TotalMix resides inside the hardware of the respective card. Up to three mixers are available, but these are separated and can't interchange data. Therefore a global mixer for all units is not possible.

12. DIGICheck

The DIGICheck software is a unique utility developed for testing, measuring and analysing digital audio streams. Although this Windows software is fairly self-explanatory, it still includes a comprehensive online help. DIGICheck 5.93 operates as multi-client ASIO host, therefore can be used in parallel to any software, be it WDM or ASIO, with both inputs and outputs (!). The following is a short summary of the currently available functions:

- **Level Meter.** High precision 24-bit resolution, 2/8/14 channels. Application examples: Peak level measurement, RMS level measurement, over-detection, phase correlation measurement, dynamic range and signal-to-noise ratios, RMS to peak difference (loudness), long term peak measurement, input check. Oversampling mode for levels higher than 0 dBFS. Vertical and horizontal mode. Slow RMS and RLB weighting filter. Supports visualization according to the K-system.
- **Hardware Level Meter for Input, Playback and Output.** Reference Level Meters freely configurable, causing near zero CPU load, because calculated from the HDSPe hardware.
- **Spectral Analyser.** World wide unique 10-, 20- or 30-band display in analog bandpass-filter technology. 192 kHz-capable!
- **Vector Audio Scope.** World wide unique Goniometer showing the typical afterglow of an oscilloscope-tube. Includes Correlation meter and level meter.
- **Totalyser.** Spectral Analyser, Level Meter and Vector Audio Scope in a single window.
- **Surround Audio Scope.** Professional Surround Level Meter with extended correlation analysis, ITU weighting and ITU summing meter.
- **ITU1770/EBU R128 Meter.** For standardized loudness measurements.
- **Bit Statistics & Noise.** Shows the true resolution of audio signals as well as errors and DC offset. Includes Signal to Noise measurement in dB and dBA, plus DC measurement.
- **Channel Status Display.** Detailed analysis and display of SPDIF and AES/EBU Channel Status data.
- **Global Record.** Long-term recording of all channels at lowest system load.
- **Completely multi-client.** Open as many measurement windows as you like, on any channels and inputs or outputs!

DIGICheck is free but works only with RME interfaces. It is constantly improved and updated. The latest version is always available on our website www.rme-audio.com, section **Downloads / Software**.

User's Guide



HDSPe AIO Pro

- ▶ **Driver Installation and Operation – Mac OS X**

13. Driver and Flash Update

13.1 Driver Installation

After fitting the card (see 5. Hardware Installation) and switching on the computer install the drivers.

RME is constantly improving the drivers. Please download the latest drivers from the RME website at <http://rme.to/downloads>. Unzip the downloaded file and start the driver installation by double-clicking **hdspe.pkg**.

During driver installation the programs **Totalmix** (TotalMix FX) and **HDSPE Settings** are copied to the Applications folder. They will automatically start into the dock if a HDSPE card is detected, and vanish when the HDSPE card is removed.

Reboot the computer when installation is done.

Driver Updates do not require to remove the existing drivers. Simply install the new driver over the existing one.

13.2 De-installing the Drivers

In case of problems the driver files can be deleted manually by dragging them to the trash bin:

```
/Applications/HDSPE Settings  
/Applications/Totalmix  
/System/Library/Extensions/HDSPEMADI.kext  
/Users/username/Library/Preferences/de.rme-audio.TotalmixFX.plist  
/Users/username/Library/Preferences/com.rme HDSPE Settings.plist  
/Library/LaunchAgents/de.rme-audio.HDSPEAgent.plist
```

Under the latest Mac OS the User/Library folder is not visible in the Finder. To unhide it start Finder, click on the menu item Go. Hold down the option (alt) key, then click on Library.

13.3 Firmware Update

The Flash Update Tool updates the HDSPE AIO Pro card to the latest firmware version. It requires an already installed driver.

Start the program **HDSPE Flash Update**. The Flash Update Tool displays the current revision of the HDSPE AIO Pro, and whether it needs an update or not. If so, then simply press the 'Update' button. A progress bar will indicate when the flash process is finished. The bar moves slowly first (program), then faster (verify).

If more than one interface card is installed, all cards can be flashed by changing to the next tab and repeating the process.

After the update the PCI Express card needs to be reset. This is done by powering down and shutting off the PC. A warm boot is not enough!

When the update fails (status: failure), the card's second BIOS will be used from the next cold boot on (Secure BIOS Technology). Therefore the card stays fully functional. The flash process should then be tried again on a different computer.

14. Configuring the HDSPe AIO Pro

14.1 Settings Dialog

Configuring the HDSPe AIO Pro is done via its own settings dialog the app **HDSPe Settings**. The mixer of the HDSPe AIO Pro, TotalMix FX, can be opened by starting the app **Totalmix**.

The HDSPe's hardware offers a number of helpful, well thought-of practical functions and options which affect how the card operates - it can be configured to suit many different requirements. The following is available in the 'Settings' dialog:

- Level of analog I/Os
- Configuration of digital I/Os
- Synchronization behaviour
- State of input and output
- Current sample rate

Any changes performed in the Settings dialog are applied immediately - confirmation (e.g. by exiting the dialog) is not required.

However, settings should not be changed during playback or record, as this can cause unwanted noises.

Use the drop down menu **Properties For** to select the unit to be configured.

Use the tab **About** to see the current driver version and firmware version of the card.

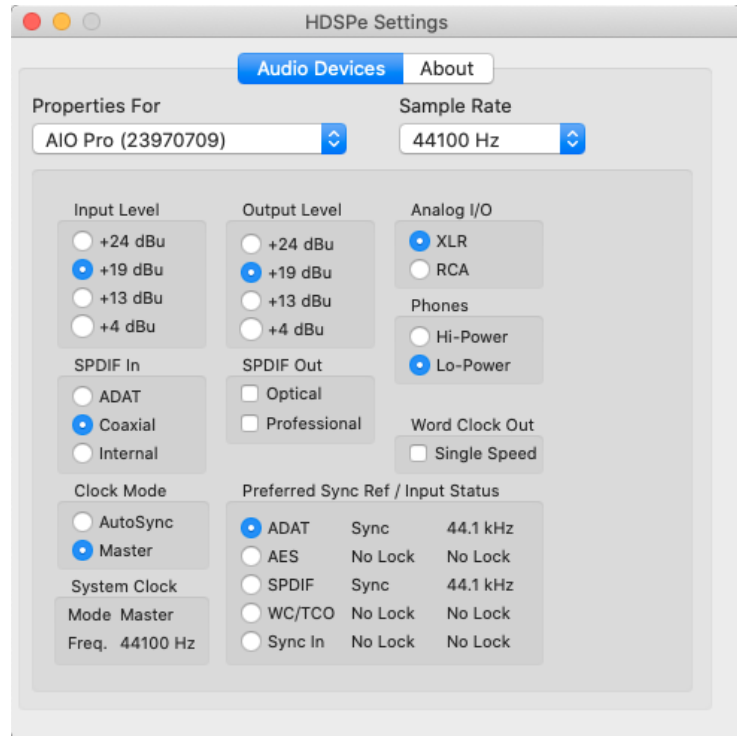

Sample Rate

Used to set the current sample rate. This is the same setting as in the Audio MIDI Setup, just added here for your convenience.

Input Level

Choice of the analog reference level for full level (0 dBFS), and therefore the sensitivity of the analog Line input.

Output Level

Choice of the analog reference level for 0 dBFS and therefore the level at the analog Line output.

Analog I/O (Breakout cable)

Choose the setting that equals the breakout cable currently in use. A wrong setting will cause incorrect reference levels.

SPDIF In

Defines the input for the SPDIF signal. 'Optical' relates to the optical TOSLINK input, 'Coaxial' to the RCA socket, 'Internal' to the jumper SPDIF IN.

SPDIF Out

The SPDIF output signal is constantly available at the phono plug. After selecting 'Optical' it is also routed to the optical TOSLINK output. Details about 'Professional' see chapter 23.3.

Phones

Choice of the reference level and with this of the level at the analog phones output. Lo-Power offers reduced background noise which is useful with highly sensitive headphones.

Word Clock Out

The word clock output signal usually equals the current sample rate. Selecting *Single Speed* causes the output signal to always stay within the range of 32 kHz to 48 kHz. So at 96 kHz sample rate, the output word clock is 48 kHz.

Clock Mode

The unit can be configured to use its internal clock source (Master), or the clock source pre-defined via *Pref Sync Ref* (AutoSync).

Input Status / Pref. Sync Ref

SyncCheck indicates whether there is a valid signal (Lock, No Lock) for each input (ADAT, SPDIF, AES, Word/TCO and Sync Internal), or if there is a valid *and* synchronous signal (Sync).

In the third row the sample rate measured by the hardware is shown.

The first row is used to pre-select the desired clock source. If the selected source isn't available, the unit will change to the next available one automatically. The current clock source and sample rate is displayed in the *System Clock* field.

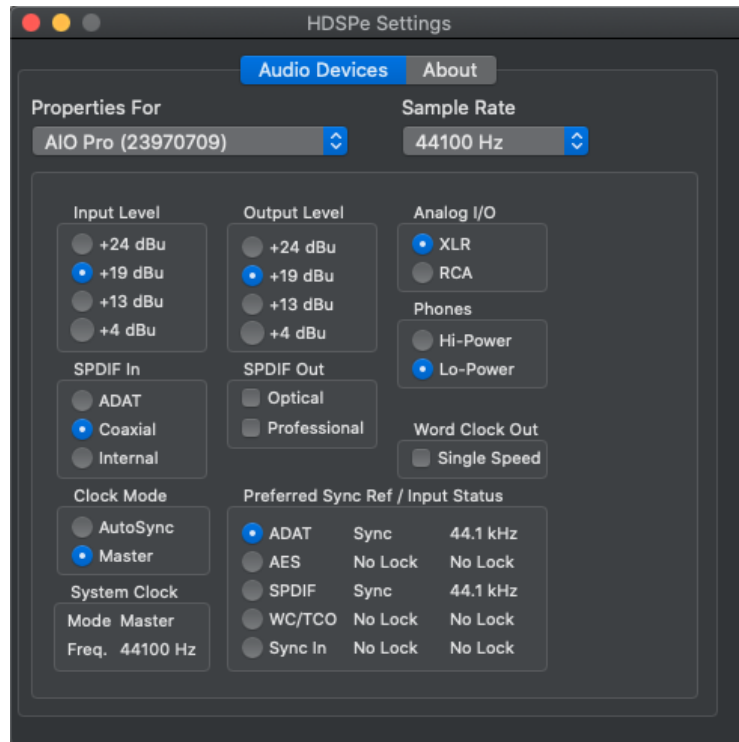

The automatic clock selection checks and changes between the clock sources ADAT, AES, SPDIF, Word/TCO and Sync Internal.

System Clock

Shows the current clock state of the HDSPe system. The system is either Master (using its own clock) or Slave (see AutoSync Ref).

14.2 Clock Modes - Synchronisation

In the digital world, all devices must be either Master (clock source) or Slave (clock receiver). Whenever several devices are linked there must always be a single master clock.



A digital system can only have one master! If the HDSPe's clock mode is set to 'Master', all other devices must be set to 'Slave'.

The HDSPe AIO Pro's intelligent clock control is very user-friendly, being able to switch between clock modes automatically. Selecting **AutoSync** will activate this mode.

In AutoSync mode, the system constantly scans all digital inputs for a valid signal. If this signal corresponds with the current playback sample rate, the card switches from the internal clock (*System Clock - Mode Master*) to a clock generated from the input signal (*System Clock - Mode Slave*). A difference to usual slave behaviour is that when the input signal is lost the card will immediately switch back to the internal clock, into Master mode.

AutoSync guarantees that record and record-while-play will always work correctly. In certain cases however, AutoSync may cause feedback in the digital carrier, so synchronization breaks down. To solve this problem switch the HDSPe clock mode to 'Internal'.

With the HDSPe AIO Pro all inputs operate simultaneously. However, as there is no input selector, the HDSPe has to be told which of the signals is the sync reference (a digital device can only be clocked from a *single* source). Via *Pref. Sync Ref* (preferred synchronization reference) a preferred input can be defined. As long as the card sees a valid signal there, this input will be designated as the sync source, otherwise the other inputs will be scanned in turn. If none of the inputs are receiving a valid signal, the card automatically switches clock mode to 'Master'.

To cope with some situations which may arise in studio practice, setting 'Pref Sync Ref' is essential. One example: An ADAT recorder is connected to the ADAT input (ADAT immediately becomes the sync source) and a CD player is connected to the SPDIF input. Try recording a few samples from the CD and you will be disappointed. Few CD players can be synchronized. The samples will inevitably be corrupted, because the signal from the CD player is read with the (wrong) clock from the ADAT i.e. out of sync. In this case, 'Pref Sync Ref' should be temporarily set to SPDIF.

RME's exclusive **SyncCheck** technology enables an easy to use check and display of the current clock status. The status box labelled **Input Status** indicates whether no signal ('No Lock'), a valid signal ('Lock') or a valid *and* synchronous signal ('Sync') is present at each of the digital clock source inputs.

In practice, SyncCheck provides the user with an easy way of checking whether all digital devices connected to the system are properly configured. With SyncCheck, finally anyone can master this common source of error, previously one of the most complex issues in the digital studio world.

15. Mac OS X FAQ

15.1 MIDI doesn't work

In some cases MIDI does not work after the installation of the HDSPe driver. The reason for this is usually visible within the **Audio MIDI Setup**. It displays no RME MIDI device, or the device is greyed out and therefore inactive. Mostly, removing the greyed out device and searching for MIDI devices again will solve the problem.

The HDSPe MIDI driver is a plugin. During installation it will be copied to **Library / Audio / MIDI Drivers**. Its name is **HDSP MADI MIDI.plugin**. The file can be displayed in the Finder and also be removed by simply dragging it to the trash bin.

15.2 Repairing Disk Permissions

Repairing permission can solve problems with the installation process - plus many others. To do this, launch **Disk Utility** located in **Utilities**. Select your system drive in the drive/volume list to the left. The **First Aid** tab to the right now allows you to check and repair disk permissions.

15.3 Supported Sample Rates

RME's Mac OS X driver supports all sampling frequencies provided by the hardware. Besides **192 kHz** and **96 kHz** this also includes **32 kHz** and **64 kHz**.

But not every software will support all the hardware's sample rates. The hardware's capabilities can easily be verified in the **Audio MIDI Setup – Audio Window**. Select the HDSPe AIO Pro. A click on **Format** will list the supported sample rates.

If the unit is in clock mode **Master**, selecting a sample rate will immediately set the device to this frequency, which can be verified in the HDSPe's Settings dialog (System Clock). **Format** thus allows you to activate any sampling frequency quickly and easily.

15.4 Channel Count under CoreAudio

At a sample rate of 88.2 or 96 kHz, the ADAT optical input and outputs operate in S/MUX mode, so the number of available channels per port is reduced from 8 to 4. At a sample rate of 176.4 and 192 kHz, the ADAT optical input and output operates in S/MUX4 mode, so the number of available channels is limited to 2.

It is not possible to change the number of CoreAudio devices without a reboot of the computer. Therefore whenever the AIO Pro changes into Double Speed (88.2/96 kHz) or Quad Speed mode (176.4/192 kHz) all devices stay present, but become partly inactive.

Core Audio	Double Speed	Quad Speed
AIO Analog 1/2	AIO Analog 1/2	AIO Analog 1/2
AIO Phones L / R*	AIO Phones L / R*	AIO Phones L / R*
AIO AES L / R	AIO AES L / R	AIO AES L / R
AIO SPDIF L / R	AIO SPDIF L / R	AIO SPDIF L / R
AIO ADAT 1 bis 2	AIO ADAT 1 bis 2	AIO ADAT 1 bis 2
AIO ADAT 3 bis 4	AIO ADAT 3 bis 4	AIO ADAT 3 bis 4
AIO ADAT 5 bis 8	AIO ADAT 5 bis 8	AIO ADAT 5 bis 8

*The phones output (AIO Phones L / R) is only available as output.

15.5 Various Information

The driver requires 10.9 or higher. Older versions of OS X are not supported.

Programs that don't support card or channel selection will use the device chosen as **Input** and **Output** in the **System Preferences – Sound** panel.

Via **Launchpad – Other – Audio MIDI Setup** the HDSPe AIO Pro can be configured for the system wide usage in more detail.

Programs that don't support channel selection will always use channels 1/2, the first stereo pair. To access other inputs, use the following workaround with TotalMix: route the desired input signal to output channels 1/2. In the channel settings of outputs 1/2 activate *Loopback*. Result: the desired input signal is now available at input channel 1/2, without further delay/latency.

Use **Configure Speakers** to freely configure the stereo or multichannel playback to any available channels.

16. Using more than one HDSPe AIO Pro

OS X supports the usage of more than one audio device within an audio software. This is done via the Core Audio function **Aggregate Devices**, which allows to combine several devices into one. All units have to be in sync, i.e. have to receive valid sync information either via word clock or by feeding synchronized signals.

- If one of the HDSPe is set to clock mode Master, all others have to be set to clock mode Slave, and have to be synced from the master, for example by feeding word, AES or SPDIF. The clock modes of all units have to be set up correctly in their Settings dialogs.
- If all units are fed with a synchronous clock, i.e. all units show *Sync* in their Settings dialog, all channels can be used at once.

Note: TotalMix resides inside the hardware of the respective card. Up to three mixers are available, but these are separated and can't interchange data. Therefore a global mixer for all units is not possible.

17. DIGICheck Mac

The DIGICheck software is a unique utility developed for testing, measuring and analysing digital audio streams. Although this app is fairly self-explanatory, it still includes a comprehensive online help. DIGICheck 0.73 operates in parallel to any software, showing all input data. The following is a short summary of the currently available functions:

- **Level Meter.** High precision 24-bit resolution, 2/8/14 channels. Application examples: Peak level measurement, RMS level measurement, over detection, phase correlation measurement, dynamic range and signal-to-noise ratios, RMS to peak difference (loudness), long term peak measurement, input check. Oversampling mode for levels higher than 0 dBFS. Supports visualization according to the K-System.
- **Hardware Level Meter for Input, Playback and Output.** Reference Level Meters freely configurable, causing near zero CPU load, because calculated from the Digiface USB hardware.
- **Spectral Analyser.** World wide unique 10-, 20- or 30-band display in analog bandpass filter technology. 192 kHz-capable!
- **Vector Audio Scope.** World wide unique Goniometer showing the typical afterglow of a oscilloscope-tube. Includes Correlation meter and level meter.
- **Totalyser.** Spectral Analyser, Level Meter and Vector Audio Scope in a single window.
- **Surround Audio Scope.** Professional Surround Level Meter with extended correlation analysis, ITU weighting and ITU summing meter.
- **ITU1770/EBU R128 Meter.** For standardized loudness measurements.
- **Bit Statistics & Noise.** Shows the true resolution of audio signals as well as errors and DC offset. Includes Signal to Noise measurement in dB and dBA, plus DC measurement.
- **Completely multi-client.** Open as many measurement windows as you like, on any channels and inputs or outputs!

DIGICheck is constantly updated. The latest version is always available on our website www.rme-audio.com, section **Downloads / Software**.

User's Guide



HDSPe AIO Pro

► Connections

18. Analog Connections

18.1 Line Inputs

The HDSPe AIO Pro has an unbalanced stereo Line input via RCA connectors. The optional analog XLR breakout cable turns the inputs into fully balanced ones.

The electronic input stage is built in a servo balanced design which handles unbalanced and balanced signals correctly, automatically adjusting the level reference.

- ! *When using unbalanced cables or sources with TRS jacks: be sure to connect the 'ring' contact of the TRS jack to ground. Otherwise noise may occur, caused by the unconnected negative input of the balanced input.*

An important point when working with an AD-converter is to maintain the full dynamic range within the best operating level. Therefore the HDSPe AIO Pro internally uses hi-quality electronic switches, which allow for a perfect adaptation to the most often used studio levels +4 dBu, +13 dBu, +19 dBu and +24 dBu.

The 'standardized' studio levels do not result in a (often desired) full scale level, but take some additional digital headroom into consideration. The amount of headroom is different in different standards, and again differently implemented by different manufacturers. We tried to make the level definitions of the HDSPe AIO PRO as compatible as possible. Additionally, to avoid confusion, the name of the reference levels now equals the max level, 0 dBFS.

Input: XLR / RCA

Ref Level	Vrms	Former Name
+24 dBu	12.28	-
+19 dBu	6.9	Lo Gain
+13 dbu	3.46	+4 dBu (with 9 dB headroom)
+4 dBu	1.23	-10 dBV (with 12 dB headroom, equals +4.2 dBu)

18.2 Line Outputs

The short circuit protected, low impedance line outputs are available as unbalanced outputs via RCA breakout cable. The optional analog XLR breakout cable provides XLR connectors and fully balanced operation.

- ! *The electronic driver circuit does not operate servo-balanced! When connecting unbalanced equipment, make sure pin 3 of the XLR output is not connected. A connection to ground will cause higher THD (distortion)!*

To maintain an optimal level for devices connected to the analog outputs, the HDSPe AIO Pro internally uses hi-quality electronic switches, which allow for a perfect adaptation of all outputs to the most often used studio levels.

As with the analog inputs, the analog output levels are defined to maintain a problem-free operation with most other devices.

XLR Out		RCA Out	
Ref Level	Vrms	Ref Level	Vrms
+24 dBu	12.28	+19 dBu	6.9
+19 dBu	6.9	+13 dbu	3.46
+13 dbu	3.46	+4 dBu	1.23
+4 dBu	1.23	-2 dBu	0.62

18.3 Headphones

The channels *Phones* of the HDSPe AIO Pro are available via an 1/4" TRS jack (stereo output). The High Power² output easily drives low impedance headphones. The output's volume is adjusted via TotalMix. Additionally, the Settings dialog provides the level settings Hi-Power (equals +19 dBu @ 0 dBFS) and Lo-Power (equals +7 dBu @ 0 dBFS).

These outputs represent ideal headphone outputs. Eventually as technically they are also ideal line outputs.

In case the headphone output should operate as Line output, an adapter TRS plug to RCA phono plugs, or TRS plug to TS plugs is required.

The pin assignment follows international standards. The left channel is connected to the tip, the right channel to the ring of the TRS jack/plug.

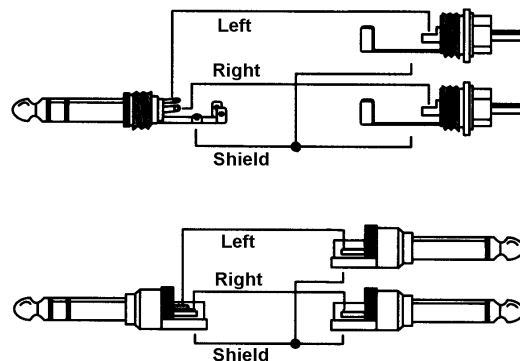

With an output impedance of 0.1 ohms, 730 mW per channel into 32 ohms at THD+N of 97 dB, the High Power² headphone output offers excellent technical data. With high impedance headphones (300 Ohm) very high 160 mW per channel at -105 dB THD+N are achieved. Switching to Lo-Power reduces the audible background noise of very sensitive headphones. Together with a mute relay for click-free switching on and off, the HDSPe AIO Pro offers an extremely high-quality headphone output directly within the computer.

19. Digital Connections

19.1 ADAT

The ADAT optical I/O of the HDSPe AIO Pro is fully compatible to all ADAT equipped units. RME's unsurpassed Bitclock PLL prevents clicks and drop outs even in extreme varipitch operation, and guarantees a lightning fast, yet low jitter and sample accurate lock to the digital input signal. A usual TOSLINK cable is sufficient for connection.

ADAT In

Interface for a device sending an ADAT signal to the HDSPe AIO Pro. Carries the channels 1 to 8. When receiving a Double Speed signal this input carries the channels 1 to 4, at Quad Speed channels 1 and 2. Can also be used as SPDIF optical input.

ADAT Out

Interface for a device receiving an ADAT signal from the HDSPe AIO Pro. Transmits channels 1 to 8. When sending a Double Speed signal, this port carries channels 1 to 4, with Quad Speed channels 1 and 2. Can also be used as SPDIF optical output.

19.2 AES/EBU

The HDSPe AIO Pro digital breakout cable provides one XLR AES/EBU input and output each. Connection is accomplished using balanced cables with XLR plugs. Input and Output are transformer-balanced and ground-free.

Besides the audio data, digital signals in SPDIF or AES/EBU format contain a channel status coding. The incoming channel status is completely ignored.

The output signal coding of the HDSPe AIO Pro has been implemented according to AES3-1992 Amendment 4:

- 32 / 44.1 / 48 kHz, 64 / 88.2 / 96 kHz, 176.4 / 192 kHz depending on the current sample rate
- Audio use
- No Copyright, Copy permitted
- Format Professional
- Category General, Generation not indicated
- 2-Channel, No Emphasis
- Aux Bits Audio use, 24 Bit
- Origin: HDSP

AES/EBU and SPDIF can contain an Emphasis information. Audio signals with Emphasis have a strong high frequency boost and thus require a high frequency attenuation on playback.

! *An Emphasis indication gets lost as there exists no standardized interface on computers to handle this information!*

Operation as second SPDIF I/O

Thanks to a highly sensitive input stage SPDIF coaxial can be fed too by using a simple cable adapter RCA/XLR. To achieve this, pins 2 and 3 of a male XLR plug are connected individually to the two pins of a phono plug. The cable shielding is only connected to pin 1 of the XLR - not to the phono plug.

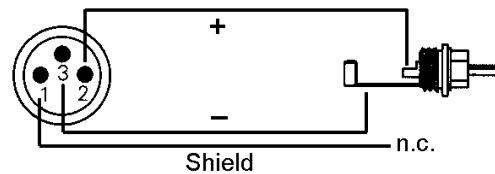

Using this cable adapter devices with coaxial SPDIF interface can be connected to the AES output of the AIO as well. Note that most consumer equipment with phono SPDIF inputs will only accept signals having a Channel Status 'Consumer' format. In such cases the adapter cable will not work.

19.3 SPDIF (Coaxial, Optical)

Input

The SPDIF input (optical/coaxial) is configured in the Settings dialog, available by a click on the hammer symbol in the Task Bar's system tray. The HDSPe AIO Pro accepts all commonly used digital sources as well as SPDIF and AES/EBU.

Output

Identical signals are available at both the optical and the coaxial output. An obvious use for this would be to connect two devices, i.e. using the HDSPe as a distributor (1 on 2).

Apart from the audio data itself, digital signals in SPDIF or AES/EBU format have a header containing channel status information. The HDSPe AIO Pro ignores the received header and creates a totally new one for its output signal.



An Emphasis indication gets lost as there exists no standardized interface on computers to handle this information!

The AIO's SPDIF channel status has been implemented according to IEC60958:

- 32 / 44.1 / 48 kHz, 64 / 88.2 / 96 kHz, 176.4 / 192 kHz depending on the current sample rate
- Audio use, Non-Audio
- No Copyright, Copy Permitted
- Format Consumer or Professional
- Category General, Generation not indicated
- 2-channel, No Emphasis
- Aux bits Audio Use, 24 bit

Operation as second AES/EBU I/O

Receiving signals in AES/EBU format requires a cable adapter. Pins 2 and 3 of a female XLR plug are connected individually to the two pins of a phono plug. The cable shielding is only connected to pin 1 of the XLR - not to the phono plug (see chapter 19.2).

Professional AES/EBU equipment can be connected to the HDSPe AIO Pro thanks to the 'Professional' format option with doubled output voltage. The required cable is the same as the one for the input, but with a male XLR plug instead of a female one.

19.4 MIDI

The HDSPe AIO Pro offers one MIDI I/O via two 5-pin DIN connectors. The MIDI ports are added to the system by the driver. Using MIDI capable software, these ports can be accessed under the name *AIO MIDI*. Using more than one HDSPe AIO Pro, the operating system adds a consecutive number to the port name, like *AIO MIDI In (2)* etc.

The MIDI In port is available for both DirectMusic MIDI and Windows MIDI simultaneously.



User's Guide



HDSPe AIO Pro

► **TotalMix FX**

20. Routing and Monitoring

20.1 Overview

The HDSPe AIO Pro includes a powerful digital real-time mixer, based on RME's unique, sample-rate independent **TotalMix** technology. It allows for practically unlimited mixing and routing operations, with all inputs and playback channels simultaneously, to any hardware outputs.

Here are some typical applications for TotalMix:

- Setting up delay-free submixes (headphone mixes). The HDSPe AIO Pro allows for up to 8 fully independent stereo submixes. On an analog mixing desk, this would equal 16 Aux sends.
- Unlimited routing of inputs and outputs (free utilisation, patchbay functionality).
- Distributing signals to several outputs at a time. TotalMix offers state-of-the-art splitter and distributor functions.
- Simultaneous playback of different programs using only one stereo output. The ASIO multi-client driver allows to use several programs at the same time, but only on different playback channels. TotalMix provides the means to mix and monitor these on a single stereo output.
- Mixing of the input signal to the playback signal (complete ASIO Direct Monitoring). RME not only is *the* pioneer of ADM, but also offers the most complete implementation of the ADM functions.
- Integration of external devices. Use TotalMix to insert external effects devices, be it in the playback or in the record path. Depending on the current application, the functionality equals insert or effects send and effects return, for example as used during real-time monitoring when adding some reverb to the vocals.

Every single input channel, playback channel and hardware output features a Peak and RMS level meter, calculated in hardware. These level displays are very useful to determine the presence and routing destinations of the audio signals.

For a better understanding of the TotalMix mixer you should know the following:

- As shown in the block diagram (next page), the record signal usually stays un-altered. TotalMix does not reside within the record path, and does not change the record level or the audio data to be recorded (exception: Loopback mode).
- The hardware input signal can be passed on as often as desired, even with different levels. This is a big difference to conventional mixing desks, where the channel fader always controls the level for all routing destinations simultaneously.
- The level meter of inputs and playback channels are connected pre-fader, to be able to visually monitor where a signal is currently present. The level meters of the hardware's outputs are connected post-fader, thus displaying the actual output level.

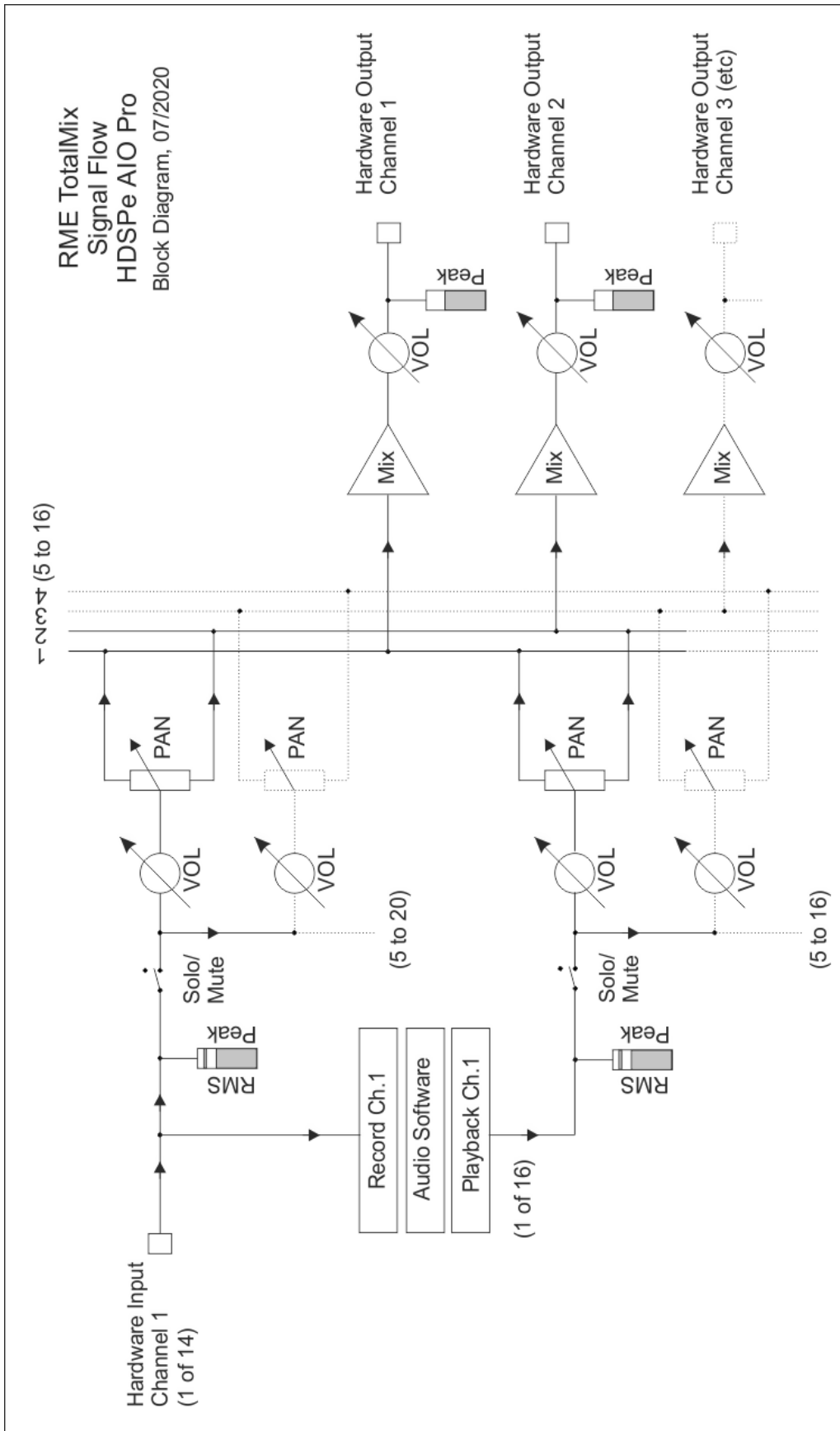

20.2 The User Interface

The visual design of the TotalMix mixer is a result of its capability to route hardware inputs and software playback channels to any hardware output. The HDSPe AIO Pro provides up to 14 input channels, 16 software playback channels, and 16 hardware output channels:

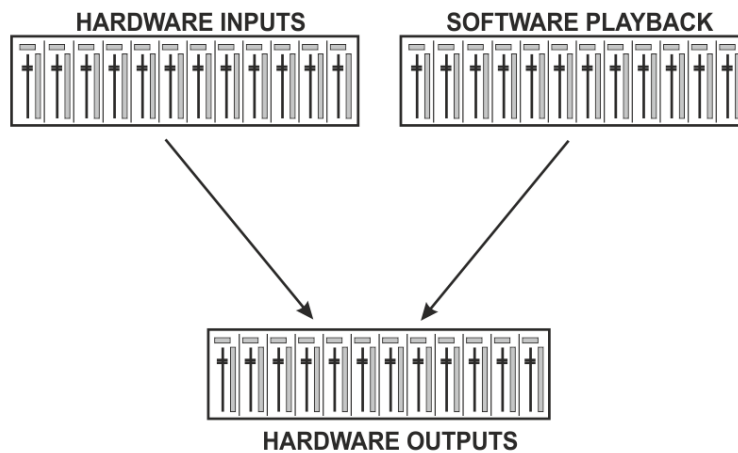

TotalMix can be used in the above view (View Options **2 Rows**). However, the default is a vertical alignment in three rows as known from an Inline desk, so that the row *Software Playback* equals the *Tape Return* of a real mixing desk:

- Top row: Hardware inputs. The level shown is that of the input signal, i. e. fader independent. Via fader and routing field, any input channel can be routed and mixed to any hardware output (bottom row).
- Middle row: Playback channels (playback tracks of the audio software). Via fader and routing field, any playback channel can be routed and mixed to any hardware output (third row).
- Bottom row (third row): Hardware outputs. Here, the total level of the output can be adjusted. This may be the level of connected loudspeakers, or the necessity to reduce the level of an overloaded submix.

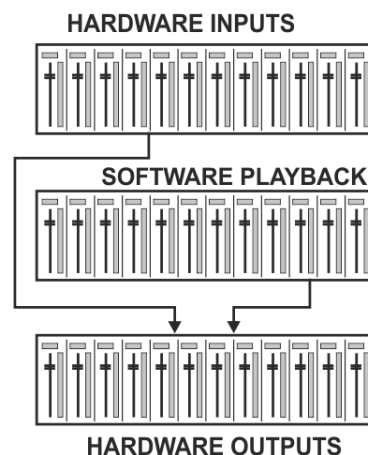

Usage in mode Submix View (Default)

Click on the Hardware Output channel in the third row where the audio signal is supposed to show up. This channel turns brighter, means it is selected as current submix. Now move the faders up from all sources – these are the input and playback channels, in the first and second row. That's it. The input (monitoring) and playback (DAW software) audio signals are now available at that very output, which can be verified immediately from the level meters reacting accordingly.

The following chapters explain step by step all functions of the user interface.

20.3 The Channels

A single channel can be switched between mono and stereo mode. The mode is set in the channel settings.

Channel name. The name field is the preferred place to select a channel by a mouse click. A double click opens a dialog to assign a different name. The original name will be shown when activating the option *Names* in the View Options.

Panorama. Routes the input signal freely to the left and right routing destination (lower label, see below). The level reduction in center position is -3 dB.

Mute and Solo. Input channels and playback channels each have a mute and solo button.

Numerical level display. Shows the current RMS or Peak level, updated twice per second. OVR means overload. The setting Peak/RMS is changed in the View Options.

Level meter. The meter shows both peak values (zero attack, 1 sample is enough for a full scale display) by means of a yellow line, and mathematically correct RMS values by means of a green bar. The RMS display has a relatively slow time constant, so that it shows the average loudness quite well. Overs are shown in red at the top of the bar. In the Preferences dialog (F2) the Peak Hold time, the over detection and the RMS reference can be set.



Fader. Determines the gain/level of the signal routed to the current routing destination (lower label). Please note that this fader is not *the* fader of the channel, but only the fader of the current routing. Compared to a standard mixing desk TotalMix does not have a channel fader, but only Aux Sends, as many as there are hardware outputs. Therefore TotalMix can create as many different Submixes as there are hardware outputs. This concept is understood best in the Submix View, but more on that later.

Below the fader the **Gain** is shown in a numerical display field, according to the current fader position. The fader can be:

- dragged with the left mouse button pressed
- moved by the mouse wheel
- set to 0 dB and $-\infty$ by a double click. The same happens with a single click plus held down Ctrl key.
- adjusted in fine mode by mouse drag and mouse wheel when holding the Shift key down

A Shift-click on a fader adds the fader to the **temporary fader group**. All faders now marked yellow are ganged, and move simultaneously in a relative way. The temporary fader group is deleted by a click on the F-symbol in the upper right of the window.



The **arrow symbol** at the bottom minimizes the channel width to that of the level meters. Another click maximizes it again. A mouse click with held Ctrl key causes all channels to the right to enlarge and minimize at once.

The lowest field shows the current **routing target**. A mouse click opens the routing window to select a routing target. The list shows all activated routings of the current channel by arrows in front of the listed entries, the current one is shown in bold letters.

An arrow is only shown with an activated routing. A routing is seen as activated when audio data is sent. As long as the fader is set to $-\infty$ the current routing will be shown in bold letters, but not have an arrow in the front.

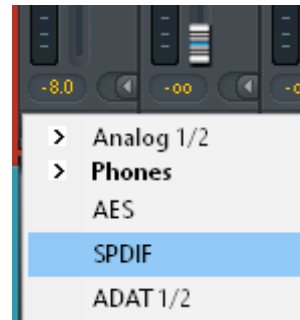

Trim Gain. After a click on the **T**-button one channel's faders are all synchronized. Instead of changing only a single routing the fader affects all the channel's active routings. For a better overview the faders currently not visible are indicated by orange triangles beside the fader path. When moving the fader the triangles also move to a new position, equalling the faders new settings.

Note that the fader button is set to the highest routing gain of all routings so that best control is offered. The gain (fader knob position) of the currently active routing (the submix selected in the third row) is shown as white triangle.

Background: TotalMix has no fixed channel fader. In case of the AIO Pro there are 16 mono Aux sends, shown alternately as single fader within the channel strip. The high number of Aux sends enables multiple and fully independent routings.

In some cases it is necessary to synchronize the gain changes of these routings. An example is the Post fader function, where a change of the singer's volume shall be performed identical to the volume change of the signal sent to the reverb device, so that the reverb level keeps its relation to the original signal. Another example is the signal of a guitar that is routed to different submixes, means hardware outputs, which gets much too loud during the solo part, and therefore needs to be reduced in volume on all outputs simultaneously. After a click on the Trim button this can be done easily and with a perfect overview.

As all channel's routings change simultaneously when Trim is active, this mode basically causes the same behaviour as a trim pot within the input channel, affecting the signal already before the mixer. That's how this function got its name.



In the View Options / Show the function Trim Gains can be globally switched on and off for all channels. The global Trim mode is recommended when using TotalMix FX as live mixing desk.

The Context Menu. With a right click on the input, playback and output channels their context menus provide advanced functionality (these menus are also available in the Matrix, but only directly on the channel labels). The entries are self-explanatory and automatically adjust to where the click is performed. On all of these the first entry opens the *Channel Layout* dialog. The input channels offer *Clear*, *Copy input* and *Paste the input mix*. On a playback channel *Copy*, *Paste* and *Clear the playback mix* are available. On an output channel *Copy* and *Mirror* functionality for the current submix is offered.

A click on the tool symbol opens the channel's **Settings** panel. The panel includes the following elements:

Stereo. Switches the channel to mono or stereo mode.

Width. Setting the stereo width. 1.00 equals full stereo, 0.00 mono, -1.00 swapped channels.

MS Proc. Activates M/S processing within the stereo channel. Monaural information is sent to the left channel, stereo information to the right.

Phase L. Inverts the phase of the left channel by 180°.

Phase R. Inverts the phase of the right channel by 180°.

Note: the functions Width, MS Proc, Phase L and Phase R affect all routings of the respective channel.



Besides Stereo/Mono, Phase L und Phase R the settings of the Hardware Outputs have further options:

Talkback. Activates this channel as receiver and output of the Talkback signal. This way Talkback can be sent to any outputs, not only the Phones in the Control Room section. Another application could be to send a certain signal to specific outputs by the push of a button.

No Trim. Sometimes channels need to have a fixed routing and level, which should not be changed in any case. An example is the stereo mix-down for recording of a live show. With *No Trim* active, the routing to this output channel is excluded from the Trim Gains function, therefore is not changed unintentionally.

Loopback. Sends the output data to the driver as record data. The corresponding submix can be recorded then. This channel's hardware input sends its data only to TotalMix, no longer to the recording software.



Another difference to the input and playback channels is the **Cue** button instead of Solo. A click on Cue sends the respective Hardware Output's audio additionally to the **Main** Out, or any of the Phones outputs (option *Assign – Cue/PFL to* in the Control Room section). With this any hardware output can be controlled and listened to through the monitoring output very conveniently.

20.4 Section Control Room

In the section Control Room the menu *Assign* is used to define the **Main Out** which is used for listening in the studio. For this output the functions Dim, Recall, Mono, Talkback and External Input are automatically applied.

Additionally the channel will be shifted from the Hardware Outputs into the Control Room section, and renamed *Main*. The same happens when assigning Main Out B or the Phones. The original name can be displayed by the function *Names* in the View Options - Show at any time.

Phones 1 to 4 will have Dim (set in Settings) and a special routing applied when Talkback is activated. Also putting them beside the Main Out increases the overview within the output section greatly.

Dim. The volume will be reduced by the amount set in Settings (F3), tab Mixer.

Recall. Sets the gain value defined in Settings - Mixer.

Speaker B. Switches audio from Main Out to Main Out B. The faders of the channels Main and Speaker B can be ganged via Link. Via *Options / Key Commands* switching to Speaker B can also be controlled by the *F-keys F4 to F8*.

Mono. Mixes left and right channel. Useful to check for mono compatibility and phase problems.

Talkback. A click on this button will dim all signals on the *Phones* outputs by an amount set up in the dialog Settings - Mixer. At the same time the control room's microphone signal (source defined in Settings - Mixer) is sent to the *Phones*. The microphone level is adjusted with the channel's input fader.

External Input. Switches Main monitoring from the mix bus to the stereo input defined in Settings (F3). The relative volume of the stereo signal is adjusted there as well.

Assign. Allows to define the Main Out, Main Out B, and up to four Phones outs.

The output for the Cue signal, which is usually Main, can also be set to one of four *Phones* outputs. The setting *Cue/PFL to* also controls the PFL monitoring.

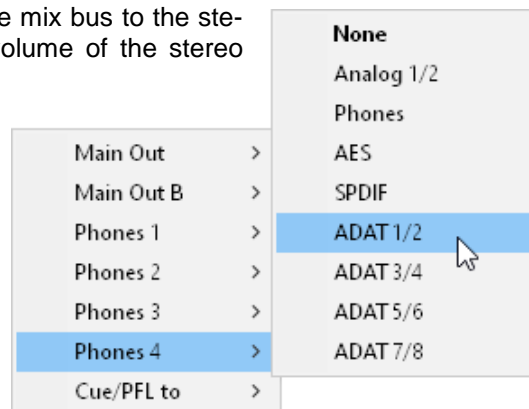

20.5 The Control Strip

The Control Strip on the right side combines different functions that are either required globally, or constantly used, and therefore should not be hidden in a menu. Still using the menu entry *Window, Hide Control Strip*, the Control Strip is shifted out of the visible area to gain more space for other elements.

The areas described in the following chapters can be minimized by a click on the triangle in their title bar.

Device selection. Select the unit to be controlled in case more than one is installed on the computer.

FX - DSP Meter. Not available for the HDSPe AIO Pro (no FX).

Undo / Redo. With the unlimited Undo and Redo changes of the mix can be undone and redone, at any time. Undo/Redo does not cover graphical changes (window size, position, channels wide/narrow etc.), and also no changes to the Layout Presets.

Undo/Redo also operates across Workspaces. Therefore a completely differently set up mixer view can be loaded via Workspace, and with a single click on Undo the previous internal mixer state is returned – but the new mixer view stays.

Global Mute Solo Fader.

Mute. Global Mute operates in a pre-fader style, muting all currently activated routings of the channel. As soon as any Mute button is pressed, the *Mute Master* button lights up in the Control Strip area. With this button all selected mutes can be switched off and on again. One can comfortably set up a mute group or activate and deactivate several mute buttons simultaneously.

Solo. As soon as any Solo button is pressed, the *Solo Master* button lights up in the Control Strip area. With this button all selected Solos are switched off and on again. Solo operates as Solo-in-Place, post fader style, as known from common mixing desks. A typical limitation for mixing desks, Solo working only globally and only for the Main Out, does not exist in TotalMix. Solo is always activated for the current submix only.

Fader. A Shift-click on a fader adds the fader to the **temporary fader group**, and the *Temp Fader Goup Master* button lights up. All faders now marked yellow are ganged, and move simultaneously in a relative way. The temporary fader group is deleted by a click on the Master Fader button.

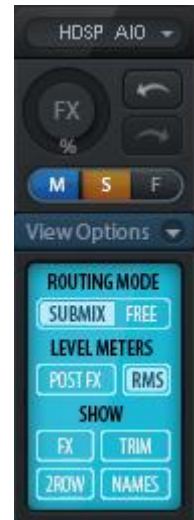

20.5.1 View Options

The field **View Options** combines different functions of routing, the level meters and the mixer view.

Routing Mode

- **Submix:** The Submix view (default) is the preferred view and delivers the quickest overview, operation and understanding of TotalMix. The click on one of the Hardware Output channels selects the respective submix, all other outputs are darkened. At the same time all routing fields are set to this channel. With Submix view, it is very easy to generate a submix for any output: select the output channel, adjust the fader and pans of first and second row – finished.
- **Free:** The Free view is for advanced users. It is used to edit several submixes simultaneously, without the need to change between them. Here one works with the routings fields of the input and playback channels only, which then show different routing destinations.

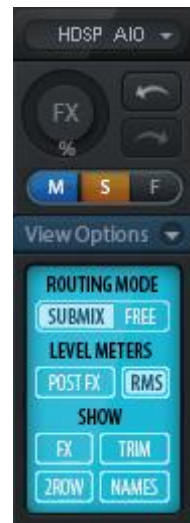

Level Meters

- **Post FX.** Not available for the HDSPe AIO Pro.
- **RMS.** The numerical level display in the channels displays peak or RMS.

Show

- **FX.** Not available for the HDSPe AIO Pro.
- **Trim.** Activates all Trim buttons on all channels. TotalMix thus behaves like a conventional, simple mixing desk. Each fader affects all active routings of the channel simultaneously, as if the fader were a trim-pot in the hardware input.
- **2 Row.** Switches the mixer view to 2 rows. Hardware Inputs and Software Playbacks are placed side by side. This view saves a lot of space, especially in height.
- **Names.** Display of the original names of channels when they had been renamed by the user.

20.5.2 Snapshots - Groups

Snapshots. Snapshots include all mixer settings, but no graphical elements like window positions, window size, number of windows, visible EQs or Settings, scroll states, Presets etc. Only the state wide/narrow of the channels is registered. Moreover the Snapshot is only temporarily stored. Loading a Workspace causes the loss of all stored Snapshots, when these all had not been saved before in a Workspace, or separately via *File / Save Snapshot as*. Via *File / Load Snapshot* the mixer states can be loaded individually.

Eight different mixes can be stored under individual names in the Snapshot section. A click on any of the eight buttons loads the corresponding Snapshot. A double click on the name field opens the dialog *Input Name* to edit the name. As soon as the mixer state is changed the button starts flashing. A click on Store lets all buttons flash, whereby the last loaded one, the base of the current state, flashes inversely. The storage finishes by clicking the desired button (means storage place). The storage process is exited by another click on the flashing Store button.

The area Snapshots can be minimized by a click on the arrow in the title bar.

Groups. The area Groups provides 4 storage places each for fader, mute and solo groups. The groups are valid per Workspace, being active and usable in all 8 Snapshots. But with this they are also lost when loading a new workspace, in case they have not been saved before in a different Workspace.

Note: The Undo function will help in case of an accidental overwrite or deletion of the groups.

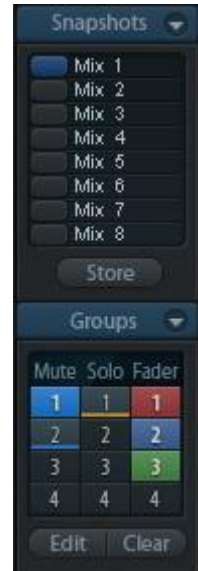

TotalMix uses flashing signals to guide you through the group setup. After a click on Edit and click on the desired storage place all desired functions for this group have to be activated or selected. The storage process is finished by another click on Edit.

When setting up a fader group make sure to not add faders that are at the most top or lowest position, except all faders of that group have this position.

The Mute groups operate – other than the global mute – exclusively for the current routing. This way you can not mute signals on all outputs unintentionally. Instead signals can be muted on specific submixes by the push of a button.

A solo group operates exactly like the global solo, signals outside the current routing are not affected.

20.5.3 Channel Layout - Layout Presets

To maintain overview within TotalMix FX channels can be hidden. Channels can also be excluded from being removed. Under *Options / Channel Layout* a dialog lists all I/Os with their current state. Selecting one or several channels enables the options to the right:

- **Hide Channel in Mixer/Matrix.** The selected channels are no longer shown in TotalMix FX, nor are they available via MIDI or OSC remote control.
- **Hide Channel in MIDI Remote 1-4.** The selected channels are hidden for MIDI remote (CC and Mackie Protocol).
- **Hide Channel in OSC Remote 1-4.** The selected channels are hidden for OSC remote control.

Hidden channels in Mixer/Matrix are still fully functional. An existing routing/mixing/FX processing stays active. But as the channel is no longer visible it can not be edited anymore. At the same time the hidden channels are removed from the list of remote controllable channels, to prevent them from being edited unnoticed.

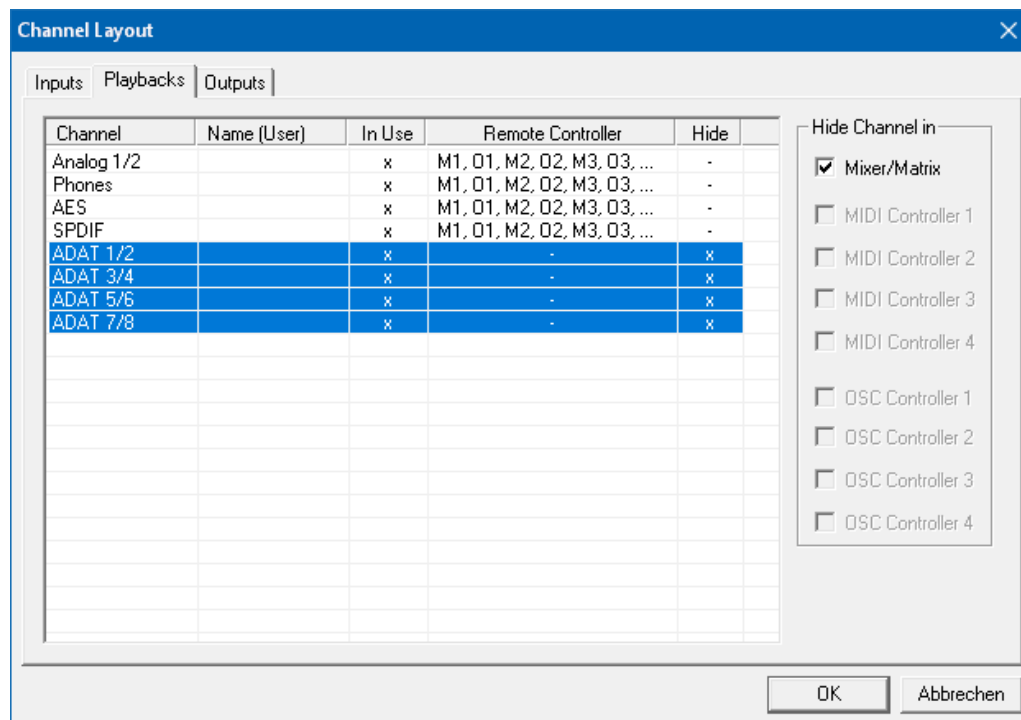

Hidden channels in *MIDI Remote* *x* are removed from the list of remote controllable channels. Within an 8-channel block of a Mackie compatible control they are skipped. The control therefore is no longer bound to consecutive orders. For example it will control channels 1, 2, and 5 to 10, when channels 3 and 4 are hidden.

The same can be done for OSC. With unnecessary channels made invisible for the OSC remote the more important channels are available as one block on the remote.

The dialog can be called directly from TotalMix by a right mouse click on any channel. The corresponding channel will then be preselected in the dialog.

In the above example ADAT channels have been made invisible. When ADAT is not used this is an easy way to remove them from the mixer completely.

Rows Inputs, Playbacks and Outputs are set up individually by the tabs at the top. A double click onto any line opens the edit field for the *Name (User)* column. Editing channel names in this dialog is quick, Enter jumps to the next line. The names of the channels in the Control Room section can only be changed this way.

After finishing those settings the whole state can be stored as **Layout Preset**. A click on *Store* and the desired memory slot makes the current channel layout recallable anytime. The button *All* makes all channels temporarily visible again.



With a simple click on a button it will then be possible to easily switch views of only the channels involved with the mixing of the drum section, the horn section, the violins, or any other useful view. An optimized remote layout can be activated here as well, with or without visible changes. Double-click the default slot name to enter any other name.

! *Layout Presets are stored within the Workspace, so make sure to save the current state before loading a different Workspace!*

The button *Sub* activates another useful special view. When in *Submix view*, *Sub* will cause all channels to disappear that are not part of the currently selected Submix/Hardware Output. *Sub* temporarily shows the mix based on all channels from Inputs and Playback row, independent from the current Layout Preset. That makes it very easy to see and to verify which channels are mixed/routed to the current output. *Sub* makes checking and verifying of mixes, but also the mix editing itself, a lot easier, and maintains perfect overview even with lots of channels.

20.5.4 Scroll Location Markers

Another feature to improve overview and working with TotalMix FX are scroll location markers (TotalMix view only). These are displayed automatically when the horizontal size of the TotalMix FX window is smaller than the channel display requires. Shown on the right side of the scrollbar of each row they have four elements:

- **Arrow to the left.** A left mouse click let the channels scroll to the very first one, or most left.
- **1. Marker number 1.** Scroll to the desired position and perform a right mouse click on 1. A dialog comes up with precise information. Once stored, a left mouse click will scroll the channels to the stored position.
- **2. Marker number 2.** See 1 for details.
- **Arrow to the right.** A left mouse click let the channels scroll the last one, or most right.



Scroll Location markers are stored in the Workspace.

Application Examples

While originally added to improve navigation in the HDSPe MADI FX (having 196 channels that never fit on any screen), the scroll location markers are also helpful with units having less channels:

- When the TotalMix FX window is intentionally made small in width, so only a few channels are shown.
- When some or all EQ panels are open. Then all relevant settings are always visible, but require a lot of space horizontally.

20.6 Preferences

The dialog Preferences can be opened via the *Options* menu or directly via F2.

Level Meters

- **Full scale samples for OVR.** Number of consecutive samples to trigger an over detection (1 to 10).
- **Peak Hold Time.** Hold time of the peak value. Adjustable from 0.1 up to 9.9 s.
- **RMS +3 dB.** Shifts the RMS value by +3 dB, so that full scale level is identical for Peak and RMS at 0 dBFS.

Mixer Views

- **FX Send follows highest Submix.**
- **FX Send follows Main Out.** Not available for the AIO Pro - no FX.
- **Center Balance/Pan when changing Mono/Stereo.** When switching a stereo channel into two mono channels the pan-pots are set fully left and right. This option will set them to center instead.
- **Disable double click fader action.** Prevents unintentional gain settings, for example when using sensitive touchpads.
- **Store channel open/close in Layout Preset.** Also loads the state of the channel panels (Settings/EQ Panel).

Dynamic Meters

Not available for the AIO Pro.

Snapshots

- **Do not load - Main Volume, Main/Phones Volumes, Control Room Settings.** The selected values stored in the Snapshot are not loaded, so the current setting is not changed.

Device Handling

- **Always init DSP devices with TotalMix FX settings.** Not available for internal cards. On boot TotalMix FX will always load the latest settings into the card.
- **Count MADI Channels per port.** Not available for the AIO Pro.
- **Disable ASIO Direct Monitoring.** Disables ASIO Direct Monitoring (ADM) for the HDSPe AIO Pro within TotalMix FX.

The screenshot shows the 'Preferences' dialog box with the following settings:

- Level Meters:** Full scale samples for OVR: 3; Peak Hold Time [s]: 1.0; RMS +3dB
- Mixer Views:** FX Send follows highest submix; FX Send follows Main Out mix; Center Balance/Pan when changing Mono/Stereo; Disable double click fader actions; Store channel open/cl. in Layout Preset
- Dynamic Meters:** Compressor/Expander; Include Gain setting; Auto Level
- Snapshots:** Do not load: Main Volume
- Device Handling:** Always init DSP devices with TotalMix FX settings; Count MADI Channels per port; Disable ASIO Direct Monitoring
- Graphics:** Use D2D (Restart required); Brightness correction: Normal Dark Light 1 Light 2
- Store Setting for:** All Users (Restart required)
- Special Options:** Lock User Interface; Enter Password

Graphics

- **Use D2D (Change requires restart).** Default on. Can be deactivated to use a compatible but CPU-taxing graphics mode, in case graphics problems show up.
- **Brightness correction.** Set TotalMix FX screen brightness to your taste, matching the monitor setting or the environment.

Store Setting for

- **All Users (Restart required).** See next chapter.

Special Options

- **Lock User Interface.** Default off. Can be activated to freeze the current mix state. Faders, buttons and knobs relating to the mix state can not be moved anymore.
- **Enter Password (Windows only).** Secures the locked user interface with an additional password.

20.6.1 Store for Current or All Users

TotalMix FX stores all settings, workspaces and snapshots for the *current user* in:

XP: C:\Documents and Settings\Username\Local Settings\Application Data\TotalMixFX

Since Vista: C:\Users\Username\AppData\Local\TotalMixFX

Current User ensures that when workstations are used by several people they all find their own settings. In case the settings should be identical or given for any user, TotalMix FX can be changed to use the *All User* directory. An admin could even write protect the file **lastHDSPeAIO1.xml**, which results in a complete reset to that file's content whenever TotalMix FX is restarted. The xml-file is updated on exit, so simply set up TotalMix as desired and exit it (right mouse click on the symbol in the notification area or Exit), then change the file attribute.

Paths under macOS X

Mac Current User: user/Library/Application Support/RME TotalMix FX

Mac All Users: /Library/Application Support/RME TotalMix FX

20.7 Settings

The dialog Settings can be opened via the *Options* menu or directly via F3.

20.7.1 Mixer Page

On the mixer page some typical settings for the mixer operation are set, like Talkback source, Dim amount when Talkback is active, the stored main volume or the input used for the External Input function.

Talkback

- **Input.** Selects the input channel of the Talkback signal (microphone in control room). Default: None.
- **Dim.** Amount of attenuation of the signals routed to the *Phones* in dB.

Listenback

- **Input.** Selects the input channel of the Listenback signal (microphone in recording room). Default: None.
- **Dim.** Amount of attenuation of the signals routed to the *Main Out* in dB.

Main Out

- **Recall.** User defined listening volume, activated by the Recall button at the unit or in TotalMix.
- **Dim.** Amount of attenuation for the Main Out in dB.
- **External Input.** Selects the stereo input that replaces the mix signal on the Main Out when activated. The volume of the stereo signal is adjusted by the slider Gain.

Solo/PFL Mode

- **Live Mode, PFL replaces Solo.** PFL means Pre Fader Listening. This feature is very useful when operating TotalMix in a live environment, as it allows to quickly listen/monitor any of the inputs by hitting the Solo button. Monitoring happens on the output set for the Cue signal via the Assign dialog.
- **Exclusive Solo/PFL Mode.** Only a single Solo or PFL can be active at a time. Activating a different one automatically deactivates the previous one.
- **2-Row Mode with only Input in first row.** The Software Playback channels are shifted to the lower row, beside the Hardware Outputs.

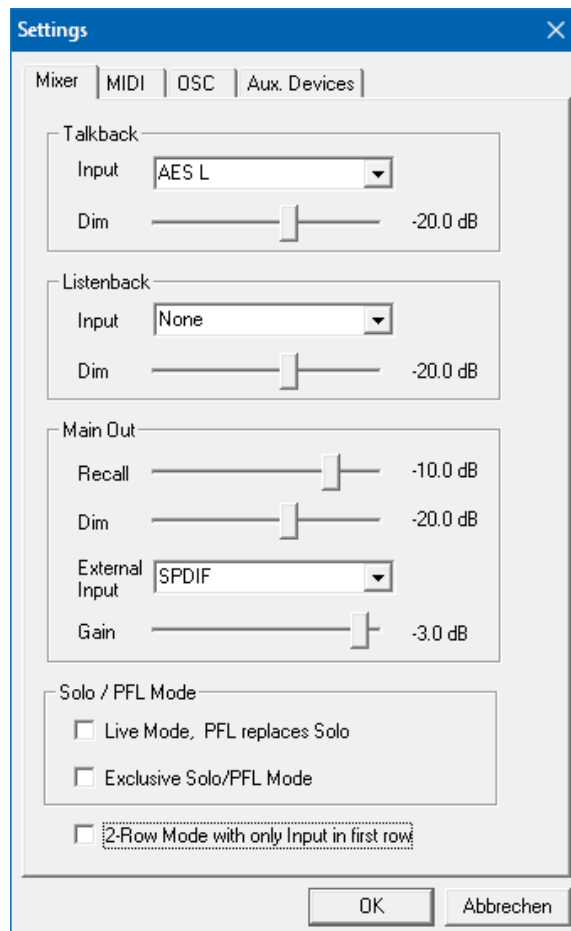

20.7.2 MIDI Page

The MIDI page has four independent settings for up to four MIDI remote controls, using CC commands or the Mackie Control protocol.

Index

Select one of four settings pages and thus remote controls. Settings are remembered automatically. To activate or deactivate any of the four remote controls check or uncheck 'In Use'.

MIDI Remote Control

- **MIDI In.** Input where TotalMix receives MIDI Remote data.
- **MIDI Out.** Output where TotalMix sends MIDI Remote data.
- **Disable MIDI in background.** Deactivates MIDI Remote Control as soon as another application is in the focus, or when TotalMix has been minimized.

Mackie Control Options

- **Enable Protocol Support.** When disabled TM FX will only react on the Control Change commands of chapter 22.5.
- **Extender to.** Sets the current remote to be an extender to the main remote. Both remotes will be shown as one block and navigate simultaneously.
- **Map Stereo to 2 Mono Channels.** One fader controls one (mono) channel. Should be disabled when stereo channels are used.
- **Submix Selection in Input/Playback Row.** Enables a selection of the submix when in first row, without having to change to the third row first. However, when using both mono and stereo channels first and third row usually do not match anymore, so the selection often becomes unclear this way.
- **Enable full LCD support.** Activates full Mackie Control LCD support with eight channel names and eight volume/pan values.
- **Send User defined Names.** Channel names defined by the user will be sent to the remote device via MIDI and – if supported – shown in its display.
- **Send Level Messages.** Activates the transmission of the level meter data. *Peak Hold* activates the peak hold function as set up for the TotalMix level meters in the preferences.

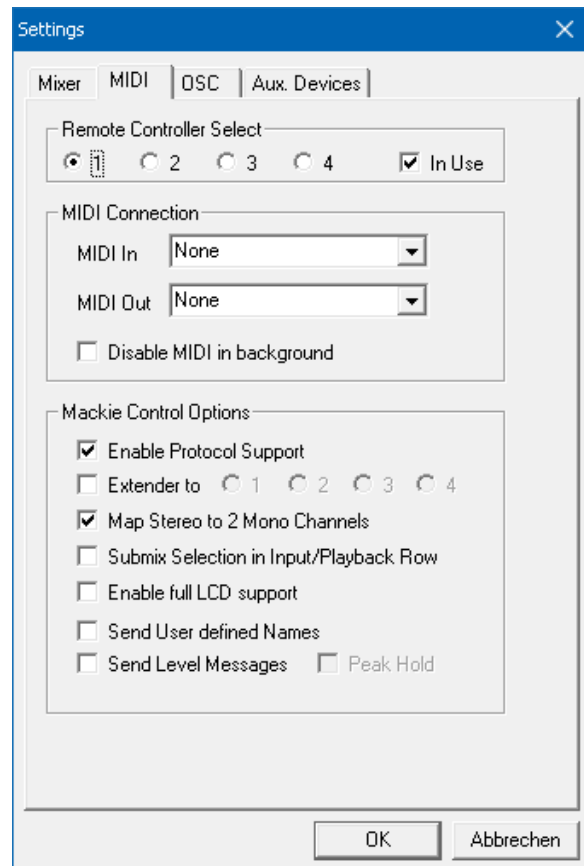

Note: When MIDI Out is set to NONE then TotalMix FX can still be controlled by Mackie Control MIDI commands, but the 8-channel block is not marked as remote target.

20.7.3 OSC Page

The OSC page has four independent settings for up to four MIDI remote controls via Open Sound Control (OSC). This is a network based remote protocol that can be used for example by Apple's iPad with the app *TouchOSC* or *Lemur* to wirelessly remote control TotalMix FX running on a Mac or Windows computer.

Index

Select one of four settings pages and thus remote controls. Settings are remembered automatically. To activate or deactivate any of the four remote controls check or uncheck 'In Use'.

TotalMix FX OSC Service

- **IP.** Shows the network address of the computer running TotalMix FX (local host). This address must be entered on the remote side.
- **Host Name.** Local computer name.
- **Port incoming.** Must match the remote entry 'Port outgoing'. Typical values are 7001 or 8000.
- **Port outgoing.** Must match the remote entry 'Port incoming'. Typical values are 9001 or 9000.

Remote Control

- **IP or Host name.** Enter the IP or host name of the remote control. Please note that the IP number usually works better than the host name.

Options

- **Send Peak Level.** Activates the transmission of the peak level meter data. *Peak Hold* activates the peak hold function as set up for the TotalMix level meters in the preferences.
- **Lock Remote to submix.** When activated the current remote control can only modify the submix selected from the drop-down list. This prevents havoc in multi-remote monitoring environments.
- **Number of faders per bank.** Available choices are 8 (default), 12, 16, 24, 32 and 48. Note that when working in underperforming networks, especially wireless, a higher number of faders might not work as smooth as expected.

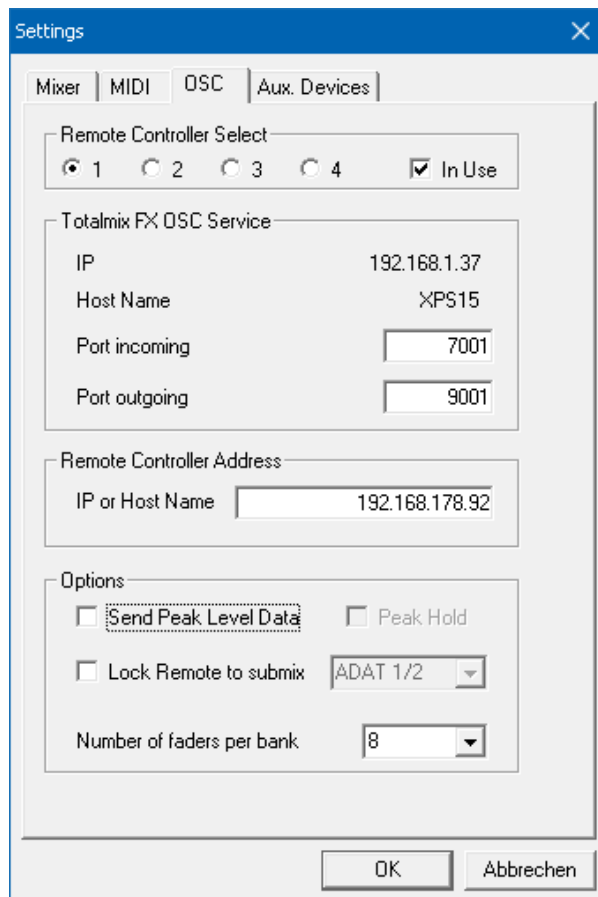

20.7.4 Aux Devices

The RME OctaMic XTC is a highly flexible hi-quality 8-channel microphone, line and instrument preamp with integrated AD-conversion to ADAT, AES/EBU and MADI, plus 4 channels of DA-conversion for monitoring. It can be used as universal front-end for the Digiface USB and other interfaces.

To simplify operation the most important parameters of the XTC (gain, 48V, Inst/PAD, AutoSet) can be controlled directly from the TotalMix FX input channels. This special remote control uses MIDI of any format (DIN, USB, MIDI over MADI).

Device Settings

- **Digital Channels.** Select where the OctaMic XTC sends its 8 analog channels to. With the Digiface USB this will be any of the four ADAT banks.
- **Device.** At this time only the OctaMic XTC is supported and can be chosen.

MIDI Settings

- **MIDI In.** Set the currently used MIDI connection to OctaMic XTC.
- **MIDI Out.** Set the currently used MIDI connection to OctaMic XTC.
- **Device ID.** Default 0. This setting relates to the current choice in Digital Channels.

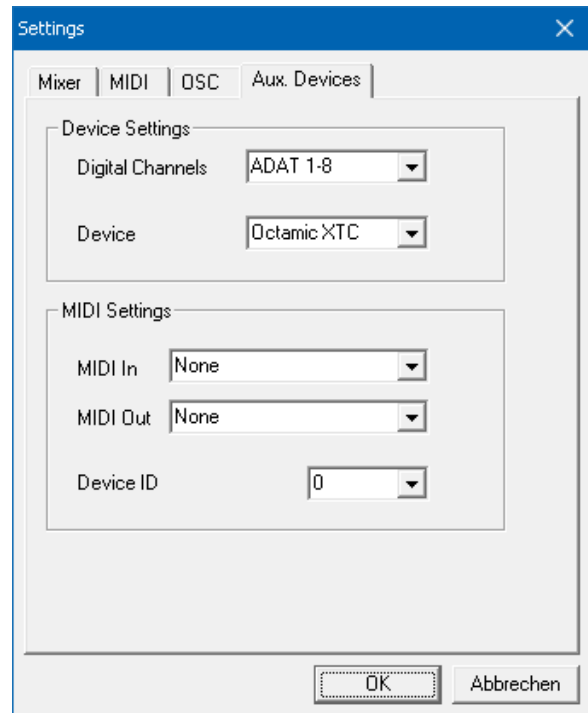

The screenshot to the right shows what happens as soon as the above settings have been confirmed with OK. The chosen ADAT channels show new elements for phantom power, Inst/PAD, Gain and AutoSet. Control operates bidirectional, so changing the gain at the unit will be mirrored in the TotalMix channels. Changing the gain in TotalMix FX will set the gain in the unit, which is also shown on the unit's display.

For the remote to work the XTC's currently used MIDI I/Os have to be set to *Control*. More details are found in the manual of the OctaMic XTC.



20.8 Hotkeys and Usage

TotalMix FX has many hotkeys and mouse/hotkey combinations to speed up and simplify the usage. The below description refers to Windows. On Mac substitute *Ctrl* in the below list with the command key (⌘).

The **Shift** key enables a fine-tuning of the gain with all faders and in the Matrix. On all knobs it will speed up the setting.

A click on a **fader** with held down **Shift** key adds the fader to the temporary fader group.

A click in the **fader path** with held down **Ctrl** key will let the fader jump to 0 dB, at the next click to $-\infty$. Same function: Double click of the mouse.

Clicking on one of the **Panorama** or **Gain** knobs with held down **Ctrl** key lets the knob jump to center position. Same function: Double click of the mouse.

Clicking on the **Panorama** knob with held down **Shift** key lets the knob jump to fully left, with **Shift-Ctrl** to fully right.

Clicking on one of the channel settings buttons (slim/normal, settings, EQ) with held down **Ctrl** key lets all channels to the right change their state. For example all panels can be opened/closed simultaneously.

A **double click** of the mouse on a knob or its numerical field opens the according *Input Value* dialog. The desired value can then be set by keyboard.

Dragging the mouse from a parameter field increases (move up) or decreases (move down) the value in the field.

Ctrl-N opens the dialog *Function Select* to open a new TotalMix window.

Ctrl-W opens the dialog *File Open* of the operating system to load a TotalMix Workspace file.

The key **W** starts the dialog *Workspace Quick Select* for a direct selection or storage of up to 30 Workspaces.

The key **M** switches the active window to Mixer view. The key **X** switches the active window to Matrix view. **Ctrl-M** opens a new Mixer window, **Ctrl-X** opens a new Matrix window. Another Ctrl-M or Ctrl-X closes the new window again.

F1 opens the online help. The Level Meter setup dialog can be opened with **F2** (same as in DIGICheck). The dialog Preferences is opened with **F3**.

Alt-F4 closes the current window.

Alt and **number** keys 1 to 8 (not on the numeric keypad!) will load the corresponding Workspace from the Workspace Quick Select feature (hotkey W).

20.9 Menu Options

Deactivate Screensaver: When active (checked) any activated Windows screensaver will be disabled temporarily.

Always on Top: When active (checked) the TotalMix window will always be on top of the Windows desktop. Note: This function may result in problems with windows containing help text, as the TotalMix window will even be on top of those windows, so the help text isn't readable.

Enable MIDI / OSC Control: Activates external MIDI control of the TotalMix mixer. In Mackie Protocol mode the channels which are currently under MIDI control are indicated by a colour change of the name field.

Submix linked to MIDI / OSC controller (1-4). The 8-channel group follows the currently selected submix, means Hardware Output, when a different submix is chosen on the remote as well as when doing this in TotalMix. When using multiple windows it can be useful to deactivate this feature for specific windows. The view will not change then.

Preferences: Opens a dialog to configure several functions of the level meters and the mixer. See chapter 19.6.

Settings. Opens a dialog to configure several functions like Talkback, Listenback, Main Out and MIDI Remote Control. See chapter 19.7.

Channel Layout. Opens a dialog to hide channels visually and from remote. See 19.5.3.

ARC & Key Commands. Opens a window to configure the programmable buttons of the Standard, Advanced and Advanced Remote USB, and of the computer's keyboard keys F4 to F8.

Reset Mix. Offers several options to reset the mixer state:

- **Straight playback with all to Main Out.** All Playback channels are routed 1:1 to the Hardware Outputs. Simultaneously all playbacks are mixed down to the Main Out. The faders in the third row are not changed.
- **Straight Playback.** All Playback channels are routed 1:1 to the Hardware outputs. The faders in the third row are not changed.
- **Clear all submixes.** Deletes all submixes.
- **Clear channel effects.** Switches off all EQs, Low Cuts, Reverb, Echo and Stereo Width and sets their knobs to default position.
- **Set output volumes.** All third row faders will be set to 0 dB, Main and Speaker B to -10 dB.
- **Reset channel names.** Removes all names assigned by the user.
- **Set all channels mono.** Reconfigures all TotalMix FX channels to mono mode.
- **Set all channels stereo.** Reconfigures all TotalMix FX channels to stereo mode.
- **Set inputs mono / outputs stereo (ADM).** Preferred setup for best ASIO Direct Monitoring compatibility. In most cases mono hardware outputs will break ADM. Mono inputs are in most cases compatible. If not wrong panning might occur.
- **Total Reset.** Playback routing 1:1 with mixdown to Main Out. Switches off all other functions.

Operational Mode. Defines TotalMix FX basic operational mode. Choices are *Full Mode* (default, mixer active, all routing options available), and *Digital Audio Workstation Mode* (straight playback routing, no input mix). See chapter 23 for details.

Network Remote Settings. Settings to remote control TotalMix FX by TotalMix Remote via network. See chapter 24.

20.10 Menu Window

Zoom Options 100%, 135%, 200%, 270%. Depending on the size of the monitor and the current resolution TotalMix FX might be much too small and the controls too tiny to easily operate them. Together with the 2 Row mode these options give a lot of different window sizes that suit all monitors and resolutions currently existing.

Hide Control Strip. Shifts the Control Strip out of the visible area to gain more space for other elements.

21. The Matrix

21.1 Overview

The mixer window of TotalMix looks and operates similar to mixing desks, as it is based on a conventional stereo design. The matrix display presents a different method of assigning and routing channels, based on a single channel or monaural design. The matrix view of the Digiface USB has the look and works like a conventional patchbay, adding functionality way beyond comparable hardware and software solutions. While most patchbays will allow you to connect inputs to outputs with just the original level (1:1, or 0 dB, as known from mechanical patchbays), TotalMix allows you to use a freely definable gain value per crosspoint.

Matrix and TotalMix are different ways of displaying the same processes. Because of this both views are always fully synchronized. Each change in one view is immediately reflected in the other view as well.

21.2 Elements of the Matrix View

The visual design of the TotalMix Matrix is mainly determined by the architecture of the HDSPe AIO Pro system:

- **Horizontal labels.** All hardware outputs
- **Vertical labels.** All hardware inputs. Below are all playback channels.
- **Green 0.0 dB field.** Standard 1:1 routing
- **Dark grey field with number.** Shows the current gain value as dB
- **Blue field.** This routing is muted
- **Red field.** Phase 180° (inverted)
- **Dark grey field.** No routing.

	Out 1	Out 2	Out 7	Out 8	Out 9
Analog 1/2	0.0	-5.5			
AES			0.0	0.0	
SPDIF					
ADAT 1/2					

To maintain overview when the window size has been reduced, the labels are floating. They won't leave the visible area when scrolling. A right mouse click on the labels brings up the context menu with the exact same options as in the mixer view: Copy / Mirror / Paste / Clear input channels and submixes.

21.3 Operation

Using the Matrix is a breeze. It is very easy to identify the current crosspoint, because the outer labels light up in orange according to the mouse position.

- If input 1 is to be routed to output 1, use the mouse and click one time on crosspoint **In 1 / AN 1** with held down Ctrl key. Two green 0.0 dB field pop in, another click removes them.
- To change the gain (equals the use of a different fader position, see simultaneous display of the mixer view), drag the mouse up or down, starting from the gain field. The value within the field changes accordingly. The corresponding fader in the mixer view is moving simultaneously, in case the currently modified routing is visible.
- On the right side is the Control Strip from the mixer window, adapted to the Matrix. The button for the temporary fader group is missing as well as all View options, as they don't make sense here. Instead the button *Mono Mode* lets you decide whether all the actions performed in the Matrix are valid for two channels or just one.

The Matrix not always replaces the mixer view, but it significantly enhances the routing capabilities and - more important - is a brilliant way to get a fast overview of all active routings. It shows you in a glance what's going on. And since the Matrix can operate monaural, it is very easy to set up specific routings with specific gains.

22. Tips and Tricks

22.1 ASIO Direct Monitoring (Windows)

Programs that support ADM (ASIO Direct Monitoring) send control commands to TotalMix. This is directly shown by TotalMix: When a fader is moved in the ASIO host the corresponding fader in TotalMix will move too. TotalMix reflects all ADM gain and pan changes in real-time.

But: the faders only move when the currently activated routing (the selected submix) corresponds to the routing in the ASIO host. The Matrix on the other hand will show any change, as it shows all possible routings in one view. For best ADM compatibility use mono inputs and stereo outputs. This setup can be activated globally under Options, Reset Mix.

22.2 Copy a Submix

TotalMix allows you to copy complete submixes to other outputs. In case a complex submix is needed with only a few changes on a different output, the whole submix can be copied to that output. Right click with the mouse on the original submix output (Hardware Output). In the context menu select Copy Submix. Then right click on the new submix output, choose Paste Submix in the context menu. Now fine tune the submix.

22.3 Doubling the Output Signal (Mirror)

If a mix should be sent out via two (or more) different hardware outputs simply mirror that mix to any number of other outputs. A right click on the original output brings up the option to *Copy/Mirror <name>*. Another right click on the new output, then selecting *Mirror of Output <name>* will paste the whole submix and then synchronize it automatically to any future changes. The outputs now always send out the same signals, but their main volume (fader) and the EQ settings stay fully independent.

22.4 Delete a Submix

The easiest and quickest way to delete complex routings is by selection of the according output channel in the mixer view by a right mouse click, and selection of *Clear Submix*. As TotalMix FX includes an unlimited undo the delete process can be undone without any problem.

22.5 Copy and Paste everywhere

The above three tips use functions found in the right click context menu available on all channels of the TotalMix FX mixer view. These menus are also available in the Matrix, but only directly on the channel labels. They are self-explanatory and automatically adjust to where the click is performed. The input channels offer *Clear*, *Copy input*, *Paste the input mix* and *Paste its FX*. On a playback channel *Copy*, *Paste* and *Clear the playback mix* are available. On an output channel *Copy* and *Mirror* functionality for the current submix is offered.

These options are very advanced and mighty tools to quickly do the impossible. Still there is no need to fear breaking something, as a simple click (or several) on the Undo button will get you back to where you started!

22.6 Recording a Submix - Loopback

TotalMix includes an internal loopback function, from the Hardware Outputs to the recording software. Instead of the signal at the hardware input, the signal at the hardware output is sent to the record software. This way, submixes can be recorded without an external loopback cable. Also the playback from a software can be recorded by another software.

The function is activated by the **Loopback** button in the Settings panel of the Hardware Outputs. In loopback mode, the signal at the hardware input of the corresponding channel is no longer sent to the recording software, but still passed through to TotalMix. Therefore TotalMix can be used to route this input signal to any hardware output. Using the subgroup recording, the input can still be recorded on a different channel.

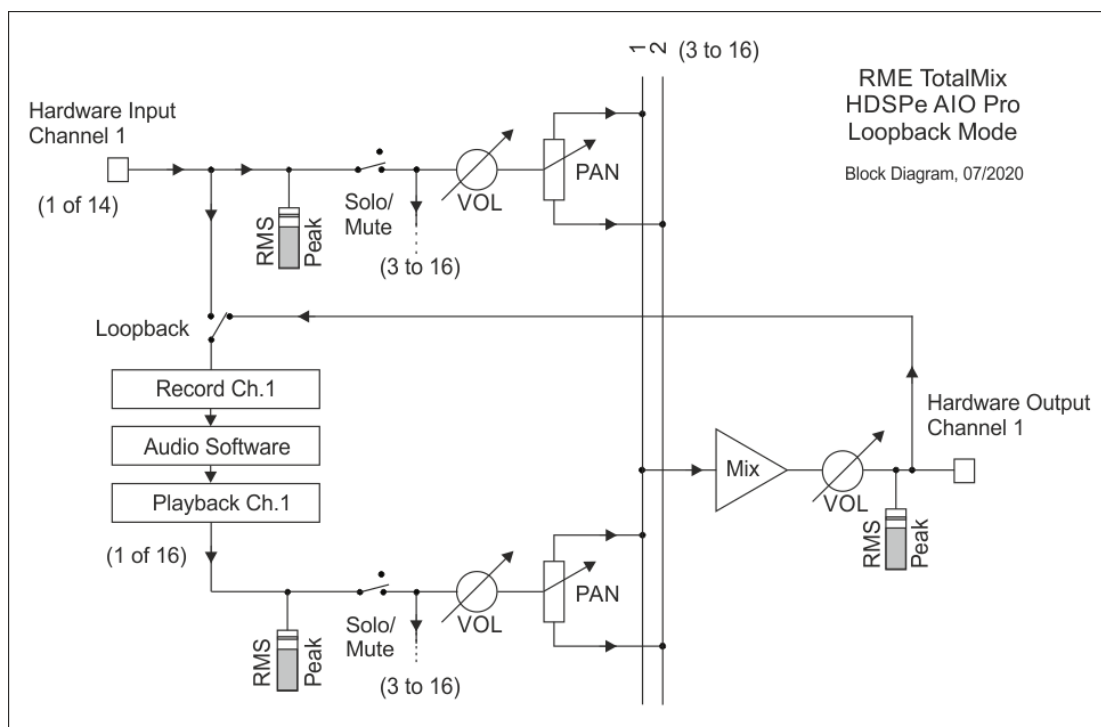

As each of the 16 hardware outputs can be routed to the record software, and none of these hardware inputs get lost, TotalMix offers an overall flexibility and performance not rivalled by any other solution.

The risk of feedbacks, a basic problem of loopback methods, is low, because the feedback can not happen within the mixer, only when the audio software is switched into monitoring mode.

The block diagram shows how the software's input signal is played back, and fed back from the Hardware Output to the software input.

Recording a Software's playback

In real world application, recording a software's output with another software will show the following problem: The record software tries to open the same playback channel as the playback software (already active), or the playback one has already opened the input channel which should be used by the record software.

This problem can easily be solved. First make sure that all rules for proper multi-client operation are met (not using the same record/playback channels in both programs). Then route the playback signal via TotalMix to a hardware output in the range of the record software, and activate Loopback for recording.

Mixing several input signals into one record channel

In some cases it is useful to record several sources into only one track. For example when using two microphones recording instruments and loudspeakers, TotalMix' Loopback mode saves an external mixing desk. Simply route/mix the input signals to the same output (third row), then redefine this output into a record channel via Loopback. This way any number of input channels from different sources can be recorded into one single track.

22.7 MS Processing

The mid/side principle is a special positioning technique for microphones, which results in a mid signal on one channel and a side signal on the other channel. These information can be transformed back into a stereo signal quite easily. The process sends the monaural mid channel to left and right, the side channel too, but phase inverted (180°) to the right channel. For a better understanding: the mid channel represents the function L+R, while the side channel represents L-R.

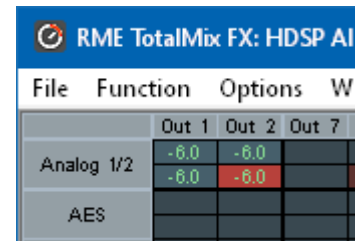

	Out 1	Out 2	Out 7
Analog 1/2	-6.0	-6.0	
AES	-6.0	-6.0	

During record the monitoring needs to be done in 'conventional' stereo. Therefore TotalMix also offers the functionality of a M/S-decoder. Activation is done in the Settings panel of the Hardware Input and Software Playback channels via the **MS Proc** button.

The M/S-Processing automatically operates as M/S encoder or decoder, depending on the source signal format. When processing a usual stereo signal, all monaural information will be shifted into the left channel, all stereo information into the right channel. Thus the stereo signal is M/S encoded. This yields some interesting insights into the mono/stereo contents of modern music productions. Additionally some very interesting methods of manipulating the stereo base and generating stereo effects come up, as it is then very easy to process the side channel with Low Cut, Expander, Compressor or Delay.

The most basic application is the manipulation of the stereo width: a change of the level of the side channel allows to manipulate the stereo width from mono to stereo up to extended.

23. MIDI Remote Control

23.1 Overview

TotalMix can be remote controlled via MIDI. It is compatible to the widely spread Mackie Control protocol, so TotalMix can be controlled with all hardware controllers supporting this standard. Examples are the Mackie Control, Tascam US-2400 or Behringer BCF 2000.

Additionally, the stereo output faders (lowest row) which are set up as *Main Out* in the Control Room section can also be controlled by the standard **Control Change Volume** via **MIDI channel 1**. With this, the main volume of the Digiface USB is controllable from nearly any MIDI equipped hardware device.

MIDI Remote Control always operates in View *Submix* mode, even when the View Option *Free* is currently selected in TotalMix FX.

23.2 Mapping

TotalMix supports the following Mackie Control surface elements*:

Element:	Meaning in TotalMix:
Channel faders 1 – 8	volume
Master fader	Main Monitor channel's faders
V-Pots 1 – 8	pan
pressing V-Pot knobs	pan = center
CHANNEL LEFT or REWIND	move one channel left
CHANNEL RIGHT or FAST FORWARD	move one channel right
BANK LEFT or ARROW LEFT	move eight channels left
BANK RIGHT or ARROW RIGHT	move eight channels right
ARROW UP or Assignable1/PAGE+	move one row up
ARROW DOWN or Assignable2/PAGE-	move one row down
EQ	Master Mute
PLUGINS/INSERT	Master Solo
STOP	Dim Main Out
PLAY	Talkback
PAN	Mono Main Out
FLIP	Speaker B
DYN	TrimGains
MUTE Ch. 1 – 8	Mute
SOLO Ch. 1 – 8	Solo
SELECT Ch. 1 – 8	Select
REC Ch. 1 – 8	select output bus (Submix)
RECORD	Recall
F1 - F8	load Snapshot 1 - 8
F9	select Main Out
F10 - F11	select Cue Phones 1 - 2

*Tested with Behringer BCF2000 Firmware v1.07 in Mackie Control emulation for Steinberg mode and with Mackie Control under Mac OS X.

23.3 Setup

Open the Preferences dialog (menu Options or F3). Select the MIDI Input and MIDI Output port where your controller is connected to.

When no feedback is needed select NONE as MIDI Output.

Check *Enable MIDI Control* in the Options menu.

23.4 Operation

The channels being under Mackie MIDI control are indicated by a colour change of the name field, black turns to brown.

The 8-fader block can be moved horizontally and vertically, in steps of one or eight channels.

In Submix View mode, the current routing destination (output bus) can be selected via REC Ch. 1 – 8. This equals the selection of a different output channel in the lowest row by a mouse click when in Submix View. In MIDI operation it is not necessary to jump to the lowest row to perform this selection. This way even the routing can be easily changed via MIDI.

Full LC Display Support. This option in Preferences (F3) activates complete Mackie Control LCD support with eight channel names and eight volume/pan values. When *Full LC Display Support* is turned off, a brief information about the first fader of the block (channel and row) is sent. This brief information is also available on the LED display of the Behringer BCF2000.

Disable MIDI in Background (menu Options, Settings) disables the MIDI control as soon as another application is in the focus, or in case TotalMix has been minimized. This way the hardware controller will control the main DAW application only, except when TotalMix is in the foreground. Often the DAW application can be set to become inactive in background too, so that MIDI control is switched between TotalMix and the application automatically when switching between both applications.

TotalMix also supports the 9th fader of the Mackie Control. This fader (labelled Master) will control the stereo output fader (lowest row) which is set up as *Main Out* in the Control Room section.

Extender support (Settings, tab MIDI) enables the use of the special Extender mixing desk, but also the addition of any other Mackie compatible remote. Setting the main remote as number 2 and the extender as number 1 will cause the extender to be on the left side. Using this function the remotes will be shown as one fader block and navigate as one.

23.5 MIDI Control

The hardware output set up as *Main Out* can be controlled by the standard **Control Change Volume** via **MIDI channel 1**. With this, the main volume of the Digiface USB is controllable from nearly any MIDI equipped hardware device.

Even if you don't want to control all faders and pans, some buttons are highly desirable to be available in 'hardware'. These are mainly the *Talkback* and the *Dim* button, and the monitoring options (listen to Phones submixes). Fortunately a Mackie Control compatible controller is not required to control these buttons, as they are steered by simple Note On/Off commands on MIDI channel 1.

The notes are (hex / decimal / keys):

Dim: 5D / 93 / **A 6**

Mono: 2A / 42 / **#F 2**

Talkback: 5E / 94 / **#A 6**

Recall: 5F / 95 / **H 6**

Speaker B: 32 / 50 / **D3**

Cue Main Out: 3E / 62 / **D 4**

Cue Phones 1: 3F / 63 / **#D 4**

Cue Phones 2: 40 / 64 / **E 4**

Snapshot 1: 36 / 54 / **#F 3**

Snapshot 2: 37 / 55 / **G 3**

Snapshot 3: 38 / 56 / **#G 3**

Snapshot 4: 39 / 57 / **A 3**

Snapshot 5: 3A / 58 / **#A 3**

Snapshot 6: 3B / 59 / **B 3**

Snapshot 7: 3C / 60 / **C 4**

Snapshot 8: 3D / 61 / **#C 4**

Trim Gains: 2D / 45 / **A 2**

Master Mute: 2C / 44 / **#G2**

Master Solo: 2B / 43 / **G2**

Furthermore all faders of all three rows can be controlled via simple **Control Change** commands. The format for the Control Change commands is:

Bx yy zz

x = MIDI channel

yy = control number

zz = value

The first row in TotalMix is addressed by MIDI channels 1 up to 4, the middle row by channels 5 up to 8 and the bottom row by channels 9 up to 12.

16 Controller numbers are used: 102 up to 117 (= hex 66 to 75). With these 16 Controllers (= faders) and 4 MIDI channels each per row, up to 64 faders can be controlled per row.

Examples for sending MIDI strings:

- Set input 1 to 0 dB: B0 66 68
- Set input 5 to maximum attenuation: B1 6A 0
- Set playback 1 to maximum: B4 66 7F
- Set Output 3 to 0 dB: B8 68 68

Note: Sending MIDI strings requires the use of programmer's logic for the MIDI channel, starting with 0 for channel 1 and ending with 15 for channel 16.

Further functions:

- Trim Gains On: BC 66 xx (BC = MIDI channel 13, xx = any value)
- Trim Gains Off: BC 66 xx or select a submix

Select submix (fader) in third row:

- channel 1/2: BC 68/69 xx
 - channel 3/4: BC 6A/6B xx
- etc.

23.6 Loopback Detection

The Mackie Control protocol requires feedback of the received commands, back to the hardware controller. So usually TotalMix will be set up with both a MIDI input and MIDI output. Unfortunately any small error in wiring and setup will cause a MIDI feedback loop here, which then completely blocks the computer (the CPU).

To prevent the computer from freezing, TotalMix sends a special MIDI note every 0.5 seconds to its MIDI output. As soon as it detects this special note at the input, the MIDI functionality is disabled. After fixing the loopback, check *Enable MIDI Control* under Options to reactivate the TotalMix MIDI.

23.7 OSC (Open Sound Control)

Besides simple MIDI notes, the Mackie Protocol and Control Change commands, TotalMix FX can also be controlled by the Open Sound Control, OSC. For details on setup and usage see chapter 19.7.3.

An OSC implementation chart can be downloaded from the RME website:

http://www.rme-audio.de/downloads/osc_table_totalmix_new.zip

RME offers an iPad template for the iOS app TouchOSC (by Hexler, available in the Apple App-Store):

http://www.rme-audio.de/downloads/tosc_tm_ipad_template.zip

The RME forum hosts further information, templates (iPhone...) and useful user feedback.

24. DAW Mode

Users that work exclusively with their DAW software, and don't want to use TotalMix FX for additional routing tasks, need a way to be sure that TotalMix FX currently doesn't change the DAW's routing. While *Reset Mix* can do so, those users would be better served with a very simple surface that offers the interface's hardware controls (gain, phantom control, instrument...), but guarantees a straight 1:1 routing for all playback channels, and has no hardware monitoring of the input channels (which is then done by the DAW software).

For such cases TotalMix FX includes an alternative operating mode. It can be booted into the so called *DAW mode*. This simplified interface is for anyone performing all monitoring and routing within the DAW. The DAW mode restarts TM FX into a light version with just two rows, no playback row, and no mixing faders in the input row. Routing is 1:1 only. Just the hardware controls (if existing) and hardware output levels are available.

To change the current mode go to the menu, Options, and click on *Operational Mode*. Choices are *Full Mode* (default, mixer active, all routing options available), and *Digital Audio Workstation Mode* (straight playback routing, no input mix).

Several useful, advanced features are still available in TotalMix FX in DAW mode:

- Talkback, External Input
- Phones definition and handling with Talkback
- Speaker A / B
- Mute and Solo
- Cue / PFL

25. TotalMix Remote

TotalMix Remote is a remote control for TotalMix FX v1.50 and up, to control the hardware mixer and effects in RME audio interfaces. TotalMix Remote mirrors the current state of the host system on the iPad and Windows/Mac computers - the entire mixing state, the complete routing, all FX settings, up to the level meters, and everything in real-time. TotalMix Remote supports up to three hosts with multiple interfaces each, allowing Apple's popular iPad and Windows/Mac computers to adjust all the mixer and FX settings from a distance, via Ethernet and WiFi.

Supported Hardware

TotalMix Remote communicates with TotalMix FX 1.50 or up. Any RME hardware that can be used with TotalMix FX is supported automatically.

Quick Start

On the host (the computer with the connected audio interface) go to the TotalMix FX menu *Options, Network Remote Settings*. Click *Enable TotalMix Remote Server* to start this service. Under Windows a Firewall warning will come up. Allow TotalMix FX or it won't work. This dialog also shows the host's IP, like 192.168.1.45.

Make sure both host and remote computer / iPad reside in the same network. Start TotalMix Remote on the remote computer / iPad (not on the host!). On the iPad, tap on the gear symbol in the upper right corner, then on *Host Connection Settings*. On Windows / Mac either the dialog comes up automatically or can be called from the *Search Connected Hosts* dialog. Type in the **host's** IP address (like 192.168.1.45) into the IP field of *Host Connection 1*, and make sure it is activated. The port defaults to 7009 and usually must not be changed. In case this port is unexpectedly occupied a warning message will be issued. Choose a different port then. Under Windows a Firewall warning will come up. Allow TotalMix Remote or it won't work.

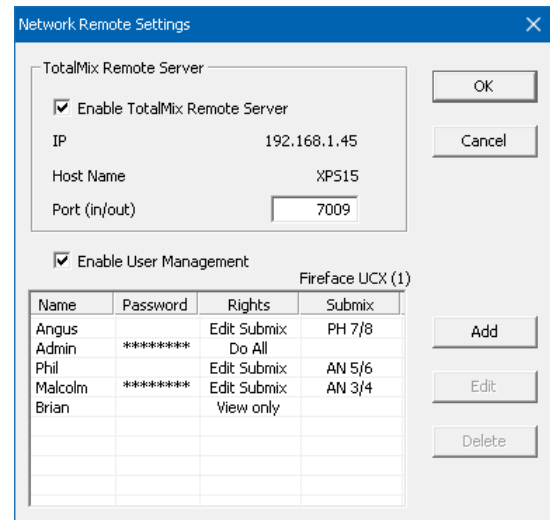

Tap Done on top or click Ok. In the mixer view the state should change from *offline* to *connected* within a few seconds.

The Add button provides access to the user-management that can be configured in detail. Here users can be defined, with and without a password, and the rights can be assigned to viewing only, changing a specific sub-mix, or full access. For example, using TotalMix FX as a monitor controller for all band members, user-management prevents the bassist from changing the guitarist's monitor mix. Or the drummer making himself too loud. Etc.

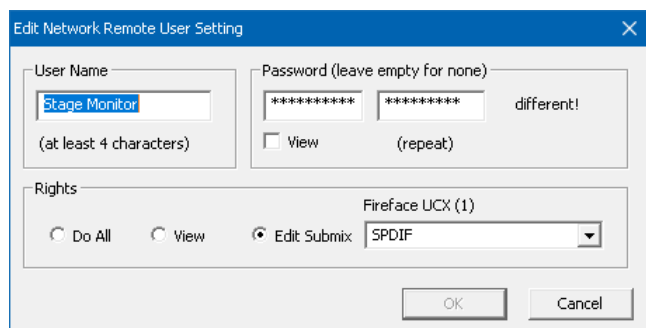

Tip

The remotes have the option *Sync Channel Layouts* active as default (in Preferences). This option transfers the Layout Presets and the current Channel Layout state from host to remote. Apart from the channel width state this option makes a mirror-style setup most easy. But when using the remote as individual setup, make sure to disable this option to have independent Layout Presets on the remote.

Limitations

- Mixer View & GUI. When connected the remote computer / iPad will immediately have the complete routing and FX settings of the host, including mono and stereo channels, but not the host's GUI setup, like panel states open/closed of Settings/EQ/Dynamic, FX panel visibility, 2-Row or 3-Row mode and channel width. Channel width states can be stored as usual per Snapshot and completely as Workspace, locally on the remote computer. They need to be loaded manually after loading a Workspace on the host in case a 100% identical view is required.
- Workspaces. The Remote shows the Quick Workspaces (hotkey W on Windows/Mac) stored on the host, and allows to remotely load them. It is not possible to save complete Workspaces with mixer state from the Remote, or on the Remote. The Workspaces saved locally include GUI information only (Channel state wide/narrow, Channel Layouts, window size and position) and further local settings, to be able to have personalized views on the remote computer, independent from the view on the host.
- Real-time behaviour. Can suffer when the network is overloaded or the WiFi reception is insufficient. Level Meters will stutter then and faders do not move smoothly.
- Background operation on iPad - is not possible. This should not be a problem as the Remote doesn't need to do anything in background, and when called up very quickly reconnects and synchronizes its state.
- State. Is shown in the upper right corner (offline or connected), or the Mac/Windows title bar.

Downloads

Remote Windows

http://www.rme-audio.de/downloads/tmfx_win_remote.zip

Remote Mac

http://www.rme-audio.de/downloads/tmfx_mac_remote.zip

iPad

From the Apple App Store, search for 'TotalMix Remote'. This app is free.

User's Guide



HDSPe AIO Pro

► Technical Reference

26. Technical Specifications

26.1 Analog Inputs

RCA (Default D-sub Breakout cable)

- Input: RCA, unbalanced
- Input impedance: 18 kOhm
- Input sensitivity switchable +24 dBu, +19 dBu, +13 dBu, +4 dBu @ 0 dBFS
- Signal to Noise ratio (SNR) @ +19/24 dBu: 117 dB RMS unweighted, 120 dBA
- Signal to Noise ratio (SNR) @ +13 dBu: 116 dB RMS unweighted, 118 dBA
- Signal to Noise ratio (SNR) @ +4 dBu: 112 dB RMS unweighted, 114 dBA
- Frequency response @ 44.1 kHz, -0.1 dB: 7 Hz – 20.5 kHz
- Frequency response @ 96 kHz, -0.5 dB: 3 Hz – 45.5 kHz
- Frequency response @ 192 kHz, -1 dB: 2 Hz – 92 kHz
- THD @ -1 dBFS: -114 dB, 0.0002 %
- THD+N @ -1 dBFS: -110 dB, 0.0003 %
- Channel separation: > 110 dB

XLR (optional D-sub Breakout cable)

As RCA, but:

- Input: XLR, servo-balanced
- Input impedance balanced: 36 kOhm, unbalanced: 18 kOhm
- Signal to Noise ratio (SNR) @ +4 dBu: 116 dB RMS unweighted, 118 dBA

26.2 Analog Outputs

RCA (Default D-sub Breakout cable)

- Output: RCA, unbalanced
- Output impedance +19/+13 dBu: 75 Ohm. +4/-2 dBu: 80 Ohm
- Output level switchable +19 dBu, +13 dBu, +4 dBu, -2 dBu @ 0 dBFS
- Signal to Noise ratio (SNR) @ +19 dBu: 117 dB RMS unweighted, 119 dBA
- Signal to Noise ratio (SNR) @ +13 dBu: 116 dB RMS unweighted, 118 dBA
- Signal to Noise ratio (SNR) @ +4 dBu: 114 dB RMS unweighted, 116 dBA
- Signal to Noise ratio (SNR) @ -2 dBu: 110 dB RMS unweighted, 112 dBA
- Frequency response @ 44.1 kHz, -0.1 dB: 10 Hz – 20.2 kHz
- Frequency response @ 96 kHz, -0.5 dB: 4 Hz – 44.6 kHz
- Frequency response @ 192 kHz, -1 dB: 3 Hz – 83 kHz
- THD @ 0 dBFS: < -107 dB, 0.0005 %
- THD+N @ 0 dBFS: -105 dB, 0.0006 %
- Channel separation: > 110 dB

XLR (optional D-sub Breakout cable)

As RCA, but:

- Output: XLR
- Output impedance +24/+19 dBu: 150 Ohm. +13/+4 dBu: 160 Ohm
- Output level switchable +24 dBu, +19 dBu, +13 dBu, +4 dBu @ 0 dBFS
- Signal to Noise ratio (SNR) @ +24 dBu: 117 dB RMS unweighted, 120 dBA

Phones

As RCA, but:

- Output: 6.3 mm TRS jack, unbalanced, stereo
- Output impedance: 0.1 Ohm
- Signal to Noise ratio (SNR) @ +19 dBu (Hi-Power): 117 dB RMS unweighted, 119 dBA
- Signal to Noise ratio (SNR) @ +7 dBu (Lo-Power): 113 dB RMS unweighted, 115 dBA
- Output level at 0 dBFS, Hi-Power, load 150 Ohm or up: +19 dBu (6.9 V)
- Output level at 0 dBFS, Lo-Power, load 16 Ohm or up: +7 dBu (1.73 V)
- THD+N @ +15 dBu, 32 Ohm load, 590 mW: -97 dB, 0.0016 %
- Max power @ 0.1% THD 32 Ohm: 730 mW per channel

26.2 Digital Inputs

AES/EBU

- 1 x XLR, transformer-balanced, galvanically isolated, according to AES3-1992
- High-sensitivity input stage (< 0.3 Vpp)
- SPDIF compatible (IEC 60958)
- Accepts Consumer and Professional format, copy protection will be ignored
- Lock range: 28 kHz – 200 kHz

SPDIF

- 1 x RCA, transformer-balanced, according to IEC 60958
- High-sensitivity input stage (< 0.3 Vpp)
- AES/EBU compatible (AES3-1992)
- Accepts Consumer and Professional format, copy protection will be ignored
- Lock range: 28 kHz – 200 kHz

ADAT Optical

- 1 x TOSLINK, format according to Alesis specification
- Standard: 8 channels 24 bit, up to 48 kHz
- Double Speed (S/MUX): 4 channels 24 bit 96 kHz
- Quad Speed (S/MUX4): 2 channels 24 bit 192 kHz
- Bitclock PLL ensures perfect synchronisation even in varispeed operation
- Lock range: 31.5 kHz – 50 kHz

26.3 Digital Outputs

AES/EBU

- 1 x XLR, transformer-balanced, galvanically isolated, according to AES3-1992
- Output level 4.0 Vpp
- Format Professional according to AES3-1992 Amendment 4
- Single Wire mode, sample rate 28 kHz up to 200 kHz

SPDIF

- 1 x RCA, transformer-balanced, according to IEC 60958
- Output level Professional 2.3 Vpp, Consumer 1.0 Vpp
- Format Professional according to AES3-1992 Amendment 4
- Format Consumer SPDIF according to IEC 60958
- Single Wire mode, sample rate 28 kHz up to 200 kHz

ADAT

- 1 x TOSLINK, format according to Alesis specification
- Standard: 8 channels 24 bit, up to 48 kHz
- Double Speed (S/MUX): 4 channels 24 bit 96 kHz
- Quad Speed (S/MUX4): 2 channels 24 bit 192 kHz

26.4 Digital

- Clocks: Internal, ADAT In, SPDIF In, AES In, Sync In, optional word clock / LTC In
- Jitter suppression of external clocks: > 50 dB (2.4 kHz)
- Effective clock jitter influence on AD and DA conversion: near zero
- PLL ensures zero dropout, even at more than 100 ns jitter
- Digital Bitclock PLL for trouble-free varispeed ADAT operation
- Supported sample rates: 28 kHz up to 200 kHz

26.5 MIDI

- 1 x MIDI I/O via 5-pin DIN jacks
- Galvanically isolated by optocoupled input
- Hi-speed mode: Jitter and response time typically below 1 ms
- Separate 128 byte FIFOs for input and output

27. Technical Background

27.1 Lock and SyncCheck

Digital signals consist of a carrier and the data. If a digital signal is applied to an input, the receiver has to synchronize to the carrier clock in order to read the data correctly. To achieve this, the receiver uses a PLL (Phase Locked Loop). As soon as the receiver meets the exact frequency of the incoming signal, it is locked. This **Lock** state remains even with small changes of the frequency, because the PLL tracks the receiver's frequency.

If an ADAT or SPDIF signal is applied to the HDSPe AIO Pro, the unit indicates LOCK, i. e. a valid input signal. This information is presented in the HDSPe AIO Pro's Settings dialog. In the status display *SyncCheck*, the state of all clocks is decoded and shown as simple text (No Lock, Lock, Sync).

Unfortunately, LOCK does not necessarily mean that the received signal is correct with respect to the clock which processes the read out of the embedded data. Example [1]: The HDSPe AIO Pro is set to 44.1 kHz internally (clock mode Master), and a mixing desk with ADAT output is connected to input ADAT. The status display will show LOCK immediately, but usually the mixing desk's sample rate is generated internally (it is Master too), and thus slightly higher or lower than the HDSPe AIO Pro's internal sample rate. Result: When reading out the data, there will frequently be read errors that cause clicks and drop outs.

Also when using multiple inputs, a simple LOCK is not sufficient. The above described problem can be solved elegantly by setting the HDSPe AIO Pro from Master to AutoSync (its internal clock will then be the clock delivered by the mixing desk). But in case another un-synchronous device is connected, there will again be a slight difference in the sample rate, and therefore clicks and drop outs.

In order to display those problems, the HDSPe AIO Pro includes **SyncCheck**. It checks all clocks used for *synchronicity*. If they are not synchronous to each other, the status display will show LOCK. If they are synchronous to each other (i. e. absolutely identical), the status display will change to SYNC. In example 1 it would have been obvious that the entry LOCK is shown in *SyncCheck* after connecting the mixing desk.

In practice, SyncCheck allows for a quick overview of the correct configuration of all digital devices. So one of the most difficult and error-prone topics of the digital studio world finally becomes easy to handle.

30.2 Latency and Monitoring

The term **Zero Latency Monitoring** has been introduced by RME in 1998 for the DIGI96 series of audio cards. It stands for the ability to pass-through the computer's input signal at the interface directly to the output. Since then, the idea behind has become one of the most important features of modern hard disk recording. In the year 2000, RME published two ground-breaking Tech Infos on the topics *Low Latency Background*, which are still up-to-date: *Monitoring*, *ZLM and ASIO*, and *Buffer and Latency Jitter*, both found on the RME website.

How much Zero is Zero?

From a technical view there is no zero. Even the analog pass-through is subject to phase errors, equalling a delay between input and output. However, delays below certain values can subjectively be claimed to be a zero-latency. This applies to analog routing and mixing, and in our opinion also to RME's Zero Latency Monitoring. The term describes the digital path of the audio data from the input of the interface to its output. The digital receiver of the HDSPe AIO Pro can't operate un-buffered, and together with TotalMix and the output via the transmitter, it causes a typical delay of 4 samples. At 44.1 kHz this equals about 90 μ s (0.00009 s), at 192 kHz only 21 μ s, and is identical for both ADAT and SPDIF/AES.

Oversampling

While the delays of digital interfaces can be disregarded altogether, the analog inputs and outputs do cause a significant delay. Modern converter chips operate with 64 or 128 times oversampling plus digital filtering, in order to move the error-prone analog filters away from the audible frequency range as far as possible. This typically generates a delay of one millisecond. A playback and re-record of the same signal via DA and AD (loopback) then causes an offset of the newly recorded track of about 2 ms.

Low Latency

The HDSPe AIO uses the latest top AD- and DA-converters with special low latency filters, offering exceptional signal to noise and distortion figures in combination with a super-fast conversion. The exact delays caused by the AD- and DA-conversion of the HDSPe AIO Pro converter chips are:

Sample rate kHz	44.1	48	96	192
AD (5 x 1/fs) ms	0.11	0.10	0.06	0.026
DA Sharp (6.25 x 1/fs) ms	0.14	0.13		
DA Sharp (5.63 x 1/fs) ms			0.06	0.029

These values represent an important step in further reducing the latency in the computer-based recording studio. The added latency - at least from AD- and DA-conversion - can simply be ignored.

Buffer Size (Latency)

Windows: This option found in the Settings dialog defines the size of the buffers for the audio data used in WDM and ASIO (see chapter 9).

Mac OS X: The buffer size is defined within the application. Only some do not offer any setting. For example iTunes is fixed to 512 samples.

AD/DA Offset under ASIO and OS X: ASIO (Windows) and Core Audio (Mac OS X) allow for the signalling of an offset value to correct buffer independent delays, like AD- and DA-conversion or the Safety Buffer described below. An analog loopback test will then show no offset, because the application shifts the recorded data accordingly. Because in real world operation analog record and playback is unavoidable, the drivers include an offset value matching the HDSPe AIO Pro's converter delays.

Therefore, in a **digital** loopback test a minimal *negative* offset of a few samples occurs. Since this small deviation is normally irrelevant, and since the offset can be corrected manually in the DAW if in doubt, this is not a problem. Furthermore, even when using the digital I/Os, an AD and DA conversion comes into play somewhere (no sound without DA conversion...).

Safety Buffer

An additional small safety buffer on the playback side has proven to be very efficient and useful. It is therefore implemented in all RME interfaces. Under Windows the AIO Pro uses a fixed additional buffer of 16 samples, under Mac 32 samples, which is added to the current buffer size. Main advantage is the ability to use lowest latency at highest CPU loads.

Core Audios Safety Offset

Under OS X, every audio interface has to use a so called *Safety Offset*, otherwise Core Audio won't operate click-free. The HDSPe AIO Pro uses a safety offset of 32 samples. This offset is signalled to the system, and the software can calculate and display the total latency of buffer size plus AD/DA offset plus safety offset for the current sample rate to inform the DAW in use.

27.3 DS - Double Speed

Sample rates above 48 kHz were not always taken for granted, and are still not widely used because of the CD format (44.1 kHz) dominating everything. Before 1998 there were no receiver/transmitter circuits available that could receive or transmit more than 48 kHz. Therefore a work-around was used: instead of two channels, one AES line only carries one channel, whose odd and even samples are being distributed to the former left and right channels. By this, you get the double amount of data, i. e. also double sample rate. Of course in order to transmit a stereo signal two AES/EBU ports are necessary then.

This transmission mode is called *Double Wire* in the professional studio world, and is also known as *S/MUX* (abbreviation for *Sample Multiplexing*) in connection with the ADAT format.

Because the ADAT interface does not allow for sampling frequencies above 48 kHz (a limitation of the interface hardware), the HDSPe AIO Pro automatically uses the *Sample Multiplexing* method in DS mode. One channel's data is distributed to two channels. As the transmission of double rate signals is done at standard sample rate (Single Speed), the ADAT outputs still deliver 44.1 kHz or 48 kHz.

The SPDIF (AES) output of the HDSPe AIO Pro provides 88.2 kHz and 96 kHz as Single Wire only.

27.4 QS – Quad Speed

In earlier times the transmission of 192 kHz had not been possible via Single Wire, so once again sample multiplexing was used: instead of two channels, one AES line transmits only one half of a channel. A transmission of one channel requires two AES/EBU lines, stereo requires even four. This transmission mode is being called *Quad Wire* in the professional studio world.

Because the ADAT interface does not allow for sampling frequencies above 48 kHz (a limitation of the interface hardware), the HDSPe AIO Pro automatically uses the *Sample Multiplexing* method in QS mode. One channel's data is distributed to four channels (S/MUX4), which limits transmission to 2 channels per optical port. Physically the ADAT output still operates at 44.1 kHz or 48 kHz.

The SPDIF and AES output of the HDSPe AIO Pro provide 176.4 kHz and 192 kHz as Single Wire only.

27.5 Noise level in DS / QS Mode

The outstanding signal to noise ratio of the HDSPe AIO Pro's AD-converters can be verified even without expensive test equipment, by using record level meters of various software. But when activating the DS and QS mode, the displayed noise level will rise from -117 dB to -109 dB at 96 kHz, and -88 dB at 192 kHz. This is not a failure. The software measures the noise of the whole frequency range, at 96 kHz from 0 Hz to 48 kHz (RMS unweighted), at 192 kHz from 0 Hz to 96 kHz.

When limiting the measurement range from 20 Hz to 20 kHz (so called audio bandpass) the value would be -117 dB again. This can be verified with RME's *DIGICheck*. The function **Bit Statistic & Noise** measures the noise floor by *Limited Bandwidth*, ignoring DC and ultrasound.

Subframe	MSB	Audio Data	LSB	AUX	CUV	RMS LB [dB+3]	RMS [dBA+3]	DC [dB]	
1 - Left	████████	████████	████████	████████	0000	-117.1	-120.2	-138.1	
2 - Right	████████	████████	████████	████████	0000	-117.2	-120.3	-138.6	
Bits	4	8	12	16	20	24	20Hz ... 20kHz	A-weighting	0Hz

The reason for this behaviour is the noise shaping technology of the analog to digital converters. They move all noise and distortion to the in-audible higher frequency range, above 30 kHz. That's how they achieve their outstanding performance and sonic clarity. Therefore the noise is slightly increased in the ultrasound area. High-frequent noise has a high energy. Add the doubled (quadrupled) bandwidth, and a wideband measurement will show a significant drop in SNR, while the human ear will notice absolutely no change in the audible noise floor.

27.6 SteadyClock

The SteadyClock FS technology of the HDSPe AIO Pro guarantees an excellent performance in all clock modes. Thanks to a highly efficient jitter suppression, the AD- and DA-conversion always operates on highest sonic level, being completely independent from the quality of the incoming clock signal.

SteadyClock has been originally developed to gain a stable and clean clock from the heavily jittery MADI data signal (the embedded MADI clock suffers from about 80 ns jitter). Using the input signals SPDIF, ADAT or word clock, you'll most probably never experience such high jitter values. But SteadyClock is not only ready for them, it would handle them just on the fly.

Common interface jitter values in real world applications are below 10 ns, a very good value is less than 2 ns.

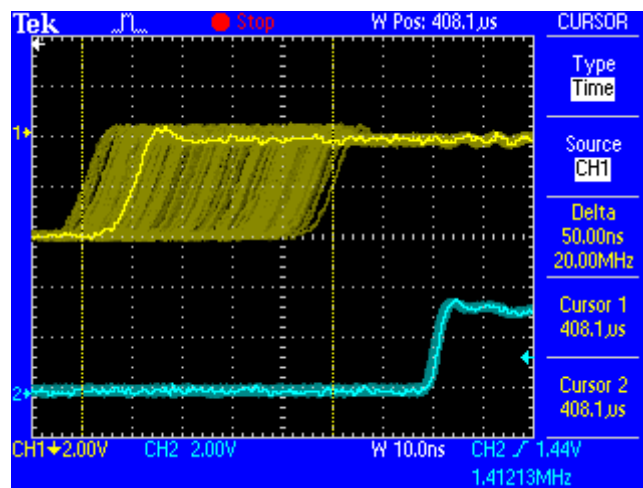

The screenshot shows an extremely jittery SPDIF signal of about 50 ns jitter (top graph, yellow). SteadyClock turns this signal into a clock with less than 1 ns jitter (lower graph, blue). The signal processed by SteadyClock is of course not only used internally, but also used to clock the digital outputs. Therefore the refreshed and jitter-cleaned signal can be used as reference clock without hesitation.

28. Diagrams

28.1 Block Diagram HDSPe AIO Pro

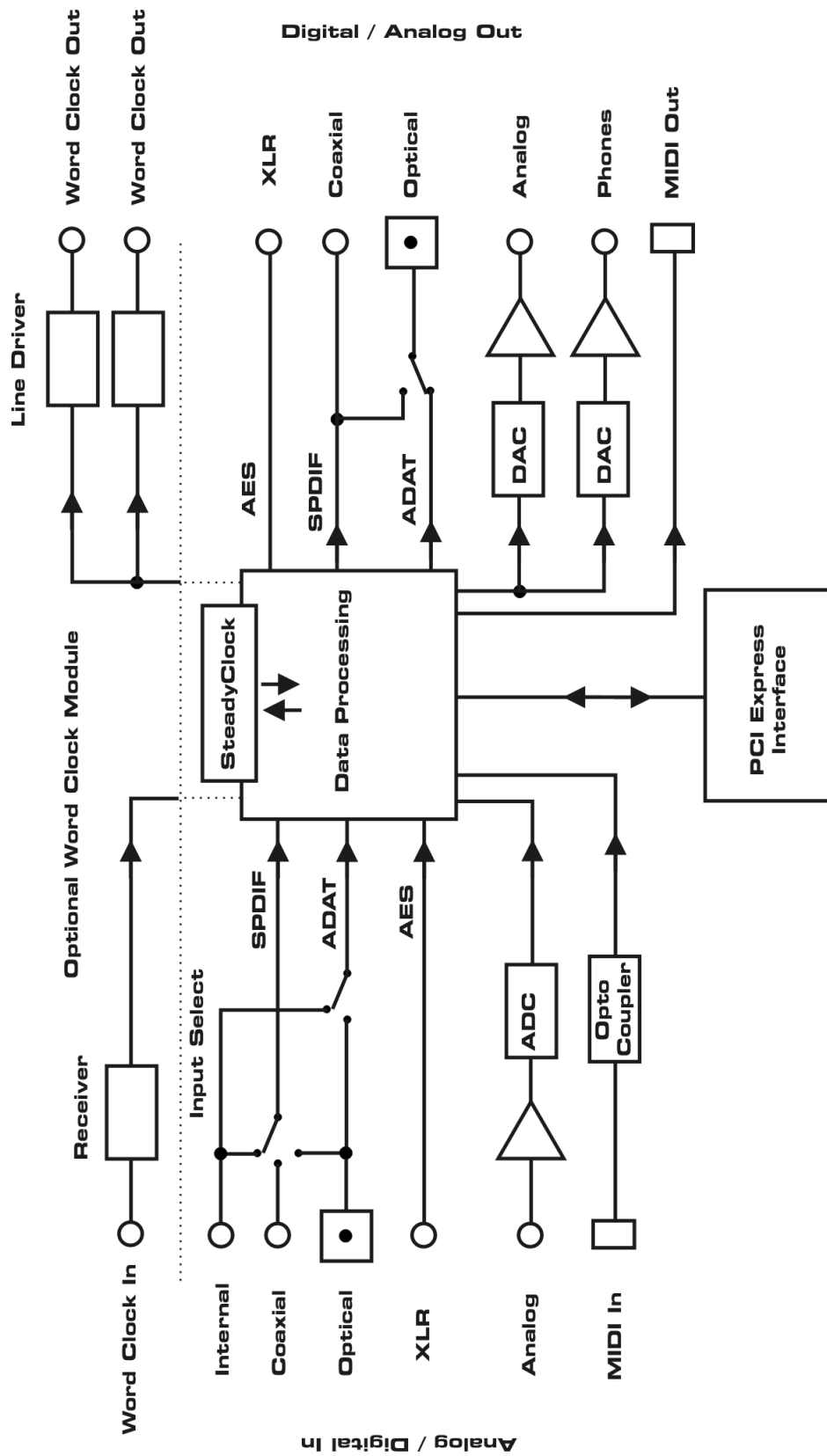

28.2 Connector Pinouts

TRS jacks of analog input / output

The stereo ¼" TRS jacks of the analog inputs and outputs are wired according to international standards:

Tip = + (hot) Ring = – (cold) Sleeve = GND

The servo balanced input and output circuitry allows to use monaural TS jacks (unbalanced) with no loss in level. This is the same as when using a TRS-jack with ring connected to ground.

TRS Phones jack

The analog monitor output on the front is accessible through a stereo ¼" TRS jack. This allows a direct connection of headphones. In case the output should operate as Line output, an adapter TRS plug to RCA phono plugs, or TRS plug to TS plugs is required.

The pin assignment follows international standards. The left channel is connected to the tip, the right channel to the ring of the TRS jack/plug.

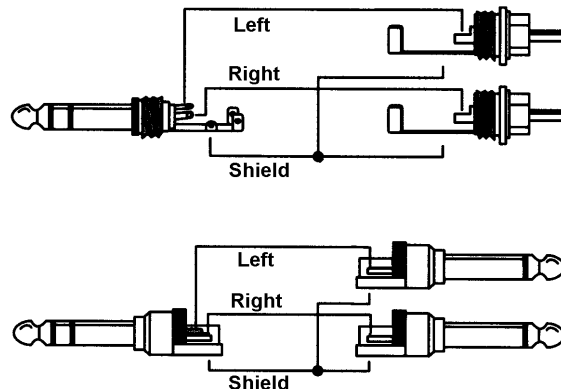

Pin assignment of the 9-pin D-sub connector, breakout cable SPDIF / AES

Pin	Name	Pin	Name	Pin	Name
1	GND	4	AES Out +	7	SPDIF In -
2	SPDIF Out +	5	AES In +	8	AES Out -
3	SPDIF In +	6	SPDIF Out -	9	AES In -

Pin assignment of the 15-pin D-type connector and analog XLR breakout cable

Pin	Name	Pin	Name	Pin	Name
1	Line In Left -	6	Line In Left +	11	Line In Right -
2	Line In Right +	7	Line Out Left -	12	Line Out Left +
3	Line Out Right +	8	Line Out Right -	13	Phones Left
4	MIDI Out (5)	9	GND/Shell	14	Phones Right
5	MIDI In (4)	10	MIDI In (5)	15	MIDI Out (4)

Pin assignment of the analog RCA/phono breakout cable

Pin	Name	Pin	Name	Pin	Name
1	GND/Shell	6	Line In Left +	11	GND/Shell
2	Line In Right +	7	n.c.	12	Line Out Left +
3	Line Out Right +	8	n.c.	13	Phones Left
4	MIDI Out (5)	9	n.c.	14	Phones Right
5	MIDI In (4)	10	MIDI In (5)	15	MIDI Out (4)

Note RCA cable: all shields and GND of the single cables are connected to the D-sub shell.

User's Guide



HDSPe AIO Pro

► Miscellaneous

29. Accessories

RME offers several optional components for the HDSPe AIO Pro:

Part Number	Description
OK0100PRO	Optical cable, TOSLINK, 1 m (3.3 ft)
OK0200PRO	Optical cable, TOSLINK, 2 m (6.6 ft)
OK0300PRO	Optical cable, TOSLINK, 3 m (9.9 ft)
BO9632	Digital RCA Breakout cable
BO968	Digital XLR / RCA Breakout cable
BOAIOPRO-CMKH	Analog RCA Breakout cable (RCA, MIDI, Phones)
BO9632-XLRMKH	Analog XLR Breakout cable (XLR, MIDI, Phones)
ARC-USB	Advanced Remote Control for TotalMix FX

30. Warranty

Each individual HDSPe AIO Pro undergoes comprehensive quality control and a complete test at IMM before shipping. The usage of high grade components should guarantee a long and trouble-free operation of the unit.

If you suspect that your product is faulty, please contact your local retailer.

Audio AG grants a limited manufacturer warranty of 6 months from the day of invoice showing the date of sale. The length of the warranty period is different per country. Please contact your local distributor for extended warranty information and service. Note that each country may have regional specific warranty implications.

In any case warranty does not cover damage caused by improper installation or maltreatment - replacement or repair in such cases can only be carried out at the owner's expense.

No warranty service is provided when the product is not returned to the local distributor in the region where the product had been originally shipped.

Audio AG does not accept claims for damages of any kind, especially consequential damage. Liability is limited to the value of the HDSPe AIO Pro. The general terms of business drawn up by Audio AG apply at all times.

31. Appendix

RME news, driver updates and further product information are available on our website:

<http://www.rme-audio.com>

Distributor: Audio AG, Am Pfanderling 60, D-85778 Haimhausen, Tel.: (49) 08133 / 918170

Manufacturer:

IMM electronics GmbH, Leipziger Strasse 32, D-09648 Mittweida

Trademarks

All trademarks, registered or otherwise, are the property of their respective owners. RME, DIGICheck and Hammerfall are registered trademarks of RME Intelligent Audio Solutions. HDSP, HDSPe AIO Pro, SyncAlign, SyncCheck, TMS, TotalMix and SteadyClock are trademarks of RME Intelligent Audio Solutions. Alesis and ADAT are registered trademarks of Alesis Corp. ADAT optical is a trademark of Alesis Corp. Microsoft, Windows, Windows XP/7/8/10 are registered trademarks or trademarks of Microsoft Corp. Steinberg, Cubase and VST are registered trademarks of Steinberg Media Technologies GmbH. ASIO is a trademark of Steinberg Media Technologies GmbH. Apple, iPhone, iPad, iOS, Mac OS and macOS X are registered trademarks of Apple Inc.

Copyright © Matthias Carstens, 07/2020. Version 1.0

Current driver version: Win: 4.30, Mac OS X 4.15, Firmware version 16

TotalMix FX: 1.65

Although the contents of this User's Guide have been thoroughly checked for errors, RME can not guarantee that it is correct throughout. RME does not accept responsibility for any misleading or incorrect information within this guide. Lending or copying any part of the guide or the RME Driver CD, or any commercial exploitation of these media without express written permission from RME Intelligent Audio Solutions is prohibited. RME reserves the right to change specifications at any time without notice.

Note on Disposal

According to the guide line RL2002/96/EG (WEEE – Directive on Waste Electrical and Electronic Equipment), valid for all european countries, this product has to be recycled at the end of its lifetime.

In case a disposal of electronic waste is not possible, the recycling can also be done by IMM electronics GmbH, the manufacturer of the HDSPe AIO Pro.

For this the device has to be sent **free to the door** to:

IMM electronics GmbH
Leipziger Straße 32
D-09648 Mittweida
Germany



Shipments not prepaid will be rejected and returned on the original sender's costs.

32. CE / FCC Compliance

CE

This device has been tested and found to comply with the limits of the European Council Directive on the approximation of the laws of the member states relating to electromagnetic compatibility according to RL2004/108/EG, and European Low Voltage Directive RL2006/95/EG.

FCC

This device complies with Part 15 of the FCC Rules. Operation is subject to the following two conditions: (1) This device may not cause harmful interference, and (2) This device must accept any interference received, including interference that may cause undesired operation.

Warning: Changes or modifications to this unit not expressly approved by the party responsible for compliance could void the user's authority to operate the equipment.

Responsible Party in USA:

Synthax United States, 6600 NW 16th Street, Suite 10, Ft Lauderdale, FL 33313
T.:754.206.4220

Trade Name: RME, Model Number: HDSPe AIO Pro

This equipment has been tested and found to comply with the limits for a Class B digital device, pursuant to Part 15 of the FCC Rules. These limits are designed to provide reasonable protection against harmful interference in a residential installation. This equipment generates, uses, and can radiate radio frequency energy and, if not installed and used in accordance with the instructions, may cause harmful interference to radio communications. However, there is no guarantee that interference will not occur in a particular installation. If this equipment does cause harmful interference to radio or television reception, which can be determined by turning the equipment off and on, the user is encouraged to try to correct the interference by one or more of the following measures:

- Reorient or relocate the receiving antenna.
- Increase the separation between the equipment and receiver.
- Connect the equipment into an outlet on a circuit different from that to which the receiver is connected.
- Consult the dealer or an experienced radio/TV technician for help.

Caution: To comply with the limits of the Class B digital device, pursuant to Part 15 of the FCC Rules, this device must be installed in computer equipment certified to comply with Class B limits. All cables used to connect to the computer and peripherals must be shielded and grounded. Operation with non-certified computers or unshielded cables may cause interference to radio or television reception.

RoHS Notice

This product has been soldered lead-free and fulfils the requirements of the RoHS directive.