

# Marshall HEADPHONES

INTRODUCING

## ACTON

MARSHALL HEADPHONES' MOST  
COMPACT SPEAKER YET ■



**MARSHALL HEADPHONES AND SPEAKERS TOGETHER WITH MARSHALL AMPLIFICATION PROUDLY PRESENTS THE RELEASE OF A BRAND-NEW SPEAKER. LET US INTRODUCE: ACTON. UNVEILED IN BERLIN IN EARLY SEPTEMBER 2014 – AVAILABLE AT MARSHALLHEADPHONES.COM AND AT LOCAL RETAILERS FROM NOVEMBER 3RD ■**

This unit might look small in stature, but don't let that fool you. The black or cream coloured Acton is an impressive and compact active stereo speaker that's packing some serious power into its stout frame. Completing the ultimate setup in your kitchen, bedroom, or office, this pint sized speaker will bring style and sound to even the smallest of spaces.

The Acton is a force to be reckoned with. With a well balanced audio boasting a clear midrange and extended highs, it gives an experience that is both articulate and pronounced. The Acton's powerful deep bass seems to defy the laws of nature for its small size. It is these hifi qualities packed into a classically designed and compact frame that set the Acton apart, positioned to take on even the largest of competitors. Acton's three custom control analogue knobs allows you to fine tune it to the exact sound you desire.

A nimble and versatile workhorse, Acton joins the Marshall family with a vengeance, carrying on a long standing tradition of loud. When it comes to looks, the Acton has inherited all the family traits, boasting the classic and durable vintage design, and iconic script logo that is so distinctly Marshall. The Acton is right at home with the rest of your Marshall collection.

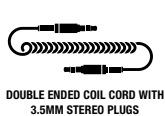

- ACTIVE STEREO LOUDSPEAKER WITH BASS REFLEX SYSTEM
- CLASS D AMPLIFIERS, 2X8W+1X25W
- FREQUENCY RANGE: 50-20,000Hz
- CROSSOVER FREQUENCY: 4200Hz
- WEIGHT: 3 KG
- SIZE: 265 X 160 X 150MM

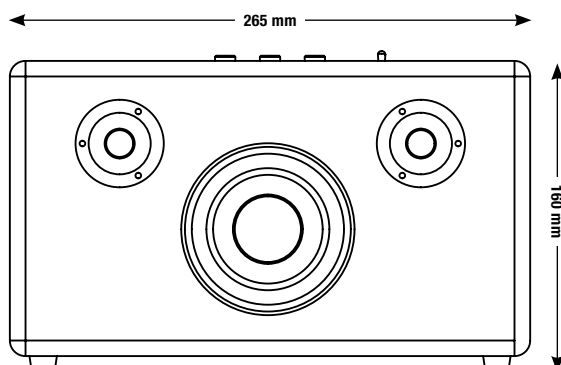

### ABOUT MARSHALL HEADPHONES

Marshall is a true rock legend. That uniquely clear and expressive sound combined with a mythical stage presence has enraptured music fans around the world for five decades. We're celebrating the brand's rich heritage with commemorative products that live and breathe Marshall.

The legacy begins in a small drum shop in Hanwell in the 1960s, where Jim Marshall sought to give a bunch of then-local guitarists the sound they wanted – a sound that was harder, crunchier and more rich. The result was the JTM45, an amp that reverberated with a sound that was much heavier than anything ever heard before. In a twist of rock and roll fate – those guitarists, much like the Marshall name, would go on to revolutionize music forever.

### MSRP

US: ..... 300 USD  
EU: ..... 250 EUR  
UK: ..... 230 GBP  
Nordic: ..... 2200 SEK

### PRESS RESOURCES

For more details please visit [marshallheadphones.com](http://marshallheadphones.com) or contact your local press agency.



[WWW.MARSHALLHEADPHONES.COM](http://WWW.MARSHALLHEADPHONES.COM)

COPYRIGHT © 2014 ALL RIGHTS RESERVED